



BOARD OF COUNTY COMMISSIONERS
WARREN COUNTY, OHIO

406 Justice Drive, Lebanon, Ohio 45036

www.co.warren.oh.us

commissioners@co.warren.oh.us

Telephone (513) 695-1250

Facsimile (513) 695-2054

TOM GROSSMANN
SHANNON JONES
DAVID G. YOUNG

22-0484

April 05, 2022

**ENTER INTO CONTRACT WITH RACK AND BALLAUER EXCAVATING CO., INC. FOR
THE COLUMBIA ROAD TURN LANE PROJECT**

WHEREAS, pursuant to Resolution #22-0408 dated March 22, 2022, this Board approved a Notice of Intent to Award Bid for the Columbia Road Turn Lane Project to Rack and Ballauer Excavating Co., Inc., for a total bid price of \$414,002.55; and

WHEREAS, all documentation, including performance bonds, insurance certificates, etc., has been submitted by the contractor; and

NOW THEREFORE BE IT RESOLVED, to enter into contract with Rack and Ballauer Excavating Co., Inc., 11321 Paddy's Run Road , Hamilton, Ohio 45013, for a total contract price of \$414,002.55; as attached hereto and made a part hereof.

Mrs. Jones moved for adoption of the foregoing resolution being seconded by Mr. Young. Upon call of the roll, the following vote resulted:

Mr. Grossmann – yea

Mr. Young – yea

Mrs. Jones – yea

Resolution adopted this 5th day of April 2022.

BOARD OF COUNTY COMMISSIONERS

Tina Osborne, Clerk

KP/

cc: c/a— Rack and Ballauer Excavating Co., Inc.
Engineer (file)
OMB Bid file



**BOARD OF COUNTY COMMISSIONERS
WARREN COUNTY, OHIO**

406 Justice Drive, Lebanon, Ohio 45036

www.co.warren.oh.us

commissioners@co.warren.oh.us

Telephone (513) 695-1250

Facsimile (513) 695-2054

**TOM GROSSMANN
SHANNON JONES
DAVID G. YOUNG**

22-0408

March 22, 2022

APPROVE NOTICE OF INTENT TO AWARD BID TO RACK AND BALLAUER EXCAVATING CO., INC. FOR THE COLUMBIA ROAD TURN LANE PROJECT

WHEREAS, bids were closed at 9:30 a.m., on March 15, 2022, and the bids received were opened and read aloud for the Columbia Road Turn Lane Project, and the results are on file in the Commissioners' Office; and

WHEREAS, upon review of such bids by Dominic Brigano, Assistant Engineer, Rack and Ballauer Excavating Co., Inc. has been determined to be the lowest and best bidder; and

NOW THEREFORE BE IT RESOLVED, upon recommendation of the Warren County Assistant Engineer, that it is the intent of this Board to award the contract to Rack and Ballauer Excavating Co., Inc., 11321 Paddy's Run Road, Hamilton, Ohio 45013, for a total bid price of \$414,002.55; and

BE IT FURTHER RESOLVED, that the President of the Board is hereby authorized to execute a "Notice of Intent to Award."

Mrs. Jones moved for adoption of the foregoing resolution being seconded by Mr. Young. Upon call of the roll, the following vote resulted:

Mr. Grossmann – yea

Mr. Young – yea

Mrs. Jones – yea

Resolution adopted this 22nd day of March 2022.

BOARD OF COUNTY COMMISSIONERS

Tina Osborne, Clerk

cc: Engineer (file)
OMB Bid file



**BOARD OF COUNTY COMMISSIONERS
WARREN COUNTY, OHIO**

406 Justice Drive, Lebanon, Ohio 45036

www.co.warren.oh.us

commissioners@co.warren.oh.us

Telephone (513) 695-1250

Facsimile (513) 695-2054

***TOM GROSSMANN
SHANNON JONES
DAVID G. YOUNG***

BID OPENING

March 15, 2022

BID OPENING –

Bids were closed at 9:30 a.m. this 15th day of March and the following bids were received, opened, and read aloud for the Columbia Road Turn Lane Project for the Warren County Engineer's Office.

| | |
|--|--------------|
| Rack and Ballauer Excavating Co., Inc. Hamilton, Ohio | \$414,002.55 |
| W. G. Stang LLC Hamilton, Ohio | \$437,969.75 |
| Fillmore Construction LLC Leesburg, Ohio | \$468,888.88 |
| Majors Enterprise Inc. Monroe, Ohio | \$568,959.10 |
| John R. Jurgensen Company Cincinnati, Ohio | \$522,925.15 |
| Barrett Paving Materials, Inc. Franklin, Ohio | \$532,438.55 |

Dominic Brigano, Assistant Engineer, will review bids for a recommendation at a later date.

cc: Bid File

OMB

E/O (file)

PLAN HOLDERS LIST

Columbia Road Turn Lane Project

Individuals or companies can be added to the plan holders list by contacting Krystal Powell at krystal.powell@co.warren.oh.us

| Name | Company | Phone Number | E-mail Address |
|-------------------|--|---------------------|--|
| Tyler Holden | KT Supply LTD. | 513-200-3432 | holden.tyler@gmail.com |
| Wess Kroll | Barrett Paving Materials, Inc. | 513-422-4662 | wkroll@barrettpaving.com |
| Amy Cox | Fillmore Construction LLC | 937-780-1301 | amy@fillmoreconstructionllc.com |
| Doug James | John R. Jurgensen Company | 513-326-6780 | Doug.james@jrnet.com |
| Lisa McNabb | W G Stang LLC | 513-863-6924 | wgstang@cinci.rr.com |
| Andrew Kloenne | Ford Development Corp. | 513-772-1521 | Akloenne@forddevelopment.com |
| Roger Cadle | Prus Construction | 513-321-7774 | rcadle@prus.us |
| Timothy Nemann | Fred A. Nemann Co. | 513-467-9400 | timnemann@aol.com |
| Chad Baker | Rack and Ballauer Excavating Co., Inc. | 513-738-2777 | chadbakerb@gmail.com |
| Ken Schibi | Tri-State Concrete Construction Inc. | 513-984-3909 | tristate.kschibi@gmail.com |
| Michael Majors | Majors Enterprises, Inc. | 513-464-6777 | majorssupply@hotmail.com |

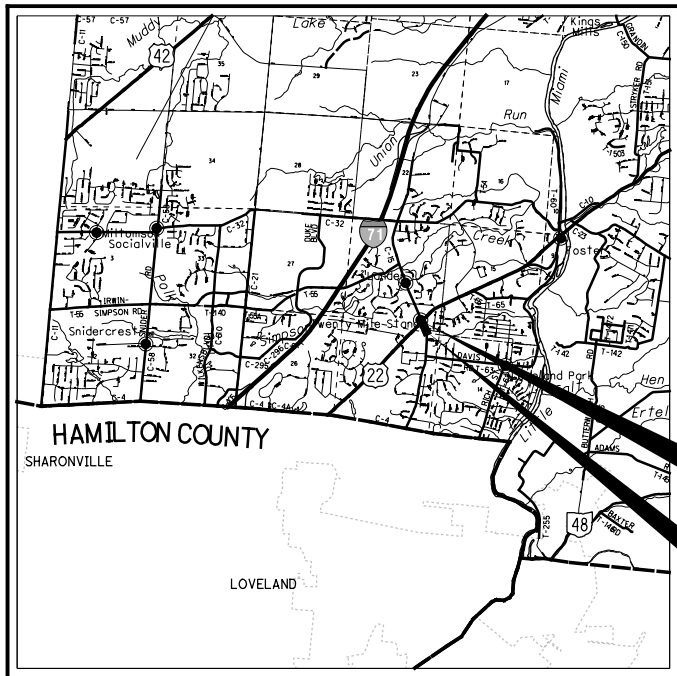

LOCATION MAP

LATITUDE: 39°18'22" LONGITUDE: -84°16'47"



| | | |
|-------------------------|-------|-------|
| PORTION TO BE IMPROVED | ————— | ————— |
| INTERSTATE HIGHWAY | ————— | ————— |
| FEDERAL ROUTES | ————— | ————— |
| STATE ROUTES | ————— | ————— |
| COUNTY & TOWNSHIP ROADS | ————— | ————— |
| OTHER ROADS | ————— | ————— |

END PROJECT
STA. 9+83.17

BEGIN PROJECT
STA. 3+77.00

WARREN COUNTY ENGINEER'S OFFICE COLUMBIA ROAD TURN LANE

PROJECT DESCRIPTION

THIS PROJECT CONSISTS OF WIDENING COLUMBIA ROAD WITH THE ADDITION OF A RIGHT TURN LANE AND SIDEWALK BETWEEN US 22/SR 3 AND KINGSLEY COURT. THIS PROJECT INCLUDES REPLACEMENT AND RELOCATION OF THE EXISTING 6" WATER MAIN WITH A NEW 8" WATER MAIN.

EARTH DISTURBED AREAS

| | |
|--|------------------------|
| PROJECT EARTH DISTURBED AREA: | 0.47 ACRES |
| ESTIMATED CONTRACTOR EARTH DISTURBED AREA: | 0.13 ACRES |
| NOTICE OF INTENT EARTH DISTURBED AREA: | N/A (NOI NOT REQUIRED) |

2019 SPECIFICATIONS

THE STANDARD SPECIFICATIONS OF THE STATE OF OHIO, DEPARTMENT OF TRANSPORTATION, INCLUDING SUPPLEMENTAL SPECIFICATIONS LISTED IN THE PLANS AND CHANGES LISTED IN THE PROPOSAL SHALL GOVERN THIS IMPROVEMENT.

INDEX OF SHEETS:

| | |
|------------------------|-------|
| TITLE SHEET | 1 |
| TYPICAL SECTIONS | 2 |
| GENERAL NOTES | 3 |
| MAINTENANCE OF TRAFFIC | 4-5 |
| GENERAL SUMMARY | 6-7 |
| ROADWAY SUBSUMMARY | 8 |
| PLAN AND PROFILE | 9 |
| CROSS SECTIONS | 10-14 |
| INTERSECTION DETAILS | 15 |
| DRIVEWAY DETAILS | 16 |
| TRAFFIC CONTROL PLAN | 17 |
| SIGNAL SHEETS | 18-20 |
| WATER WORK | 21-24 |

TITLE SHEET

UNDERGROUND UTILITIES
 Contact Two Working Days
 Before You Dig

OHIO811.org
 Before You Dig

OHIO811, 8-1-1, or 1-800-362-2764
 (Non-members must be called directly)

PLAN PREPARED BY:
**CARPENTER
 MARTY** transportation

10816 MILLINGTON COURT, SUITE 104
 CINCINNATI, OH 45242
 513.505.8797 • WWW.CMTRAN.COM

ENGINEER'S SEAL:



SIGNED: *Bradley A. Ackel*
 DATE: 02/07/2022

| STANDARD CONSTRUCTION DRAWINGS | | | | SUPPLEMENTAL SPECIFICATIONS | |
|--------------------------------|----------|-----------|---------|-----------------------------|-----------|
| CB-3A | 7/16/21 | TC-65.11 | 7/21/17 | 800 | 1/21/2022 |
| MH-3 | 7/16/21 | TC-71.10 | 1/19/18 | 809 | 1/18/2019 |
| DM-1.1 | 7/17/20 | TC-74.10 | 1/21/22 | 909 | 1/21/2022 |
| DM-1.2 | 7/16/21 | TC-82.10 | 1/18/19 | | |
| DM-4.4 | 1/15/16 | TC-85.21 | 7/16/21 | | |
| BP-3.1 | 1/17/20 | TC-85.22 | 1/19/18 | | |
| BP-4.1 | 7/19/13 | | | | |
| BP-5.1 | 1/18/19 | MT-95.31 | 7/19/19 | | |
| BP-7.1 | 7/17/20 | MT-95.50 | 7/21/17 | | |
| | | MT-101.90 | 7/17/20 | | |
| TC-41.20 | 10/18/13 | | | | |
| TC-41.41 | 10/18/13 | HL-30.11 | 1/15/21 | | |
| TC-42.20 | 10/18/13 | | | | |
| TC-52.10 | 10/18/13 | | | | |
| TC-52.20 | 1/15/21 | | | | |
| TC-65.10 | 1/17/14 | | | | |

APPROVED _____
 DATE _____ WARREN COUNTY ENGINEER

DESIGN AGENCY



DESIGNER

BTP

REVIEWER

BAA 06-28-21

PROJECT ID

COLUMBIA RD

SHEET TOTAL

1 24

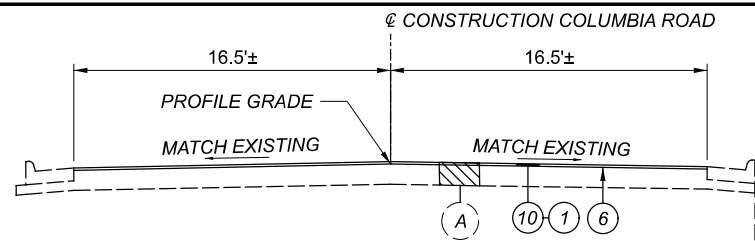

MILL & FILL SECTION - COLUMBIA ROAD

SECTION APPLIES:
 STA. 3+77.00 TO STA. 5+60.00

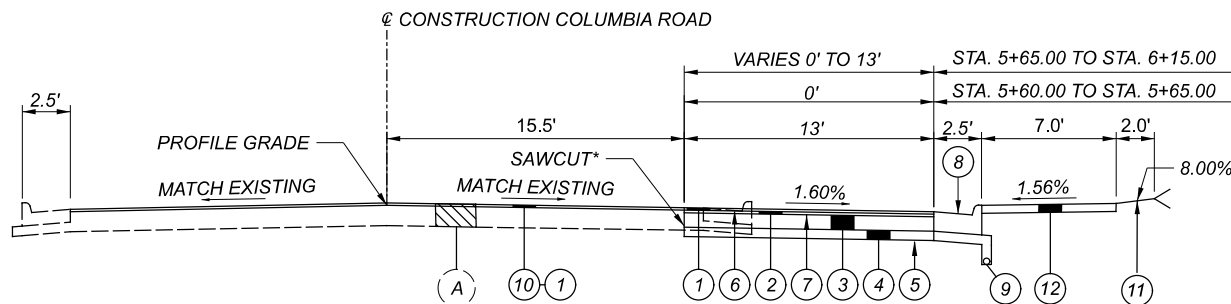

NORMAL SECTION - PROPOSED COLUMBIA ROAD

SECTION APPLIES:
 STA. 5+60.00 TO STA. 7+32.00

*NOTE: SAWCUT 1' MIN. FROM EX. CURB OR TO SOLID PAVEMENT

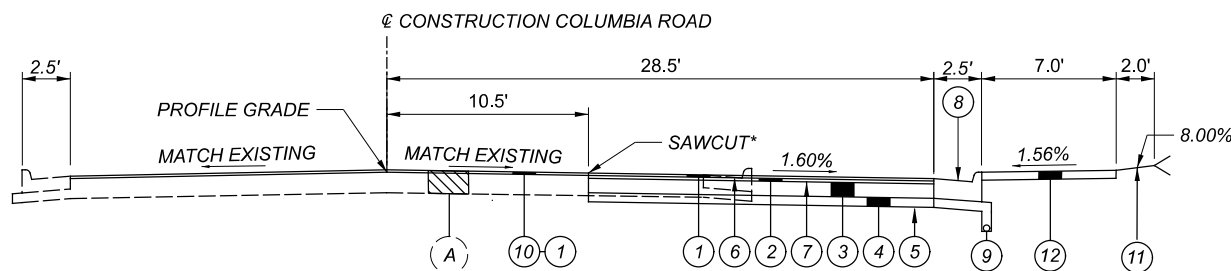

NORMAL SECTION - PROPOSED COLUMBIA ROAD

SECTION APPLIES:
 STA. 7+32.00 TO STA. 9+41.13
 STA. 9+41.13 TO STA. 9+83.17 (SEE INTERSECTION DETAIL)

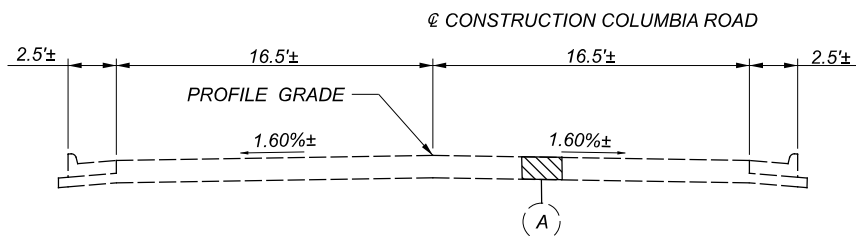

NORMAL SECTION - EXISTING COLUMBIA ROAD

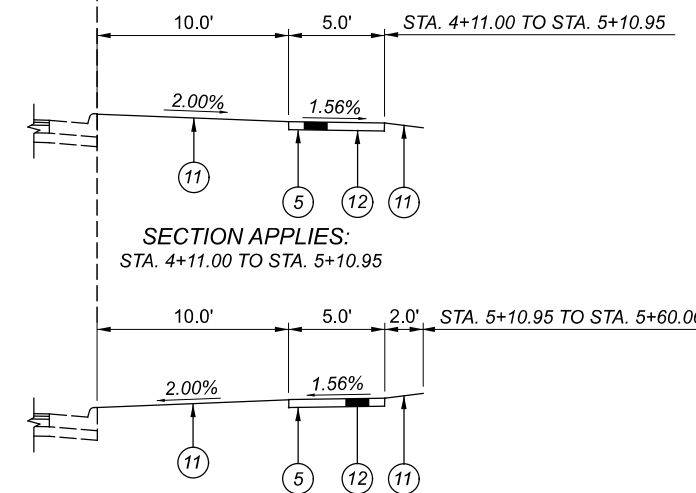

SECTION APPLIES:
 STA. 4+11.00 TO STA. 5+10.95

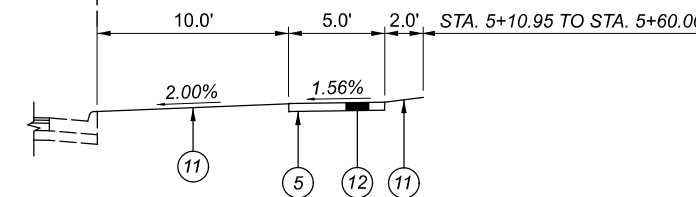

SECTION APPLIES:
 STA. 5+10.95 TO STA. 5+60.00

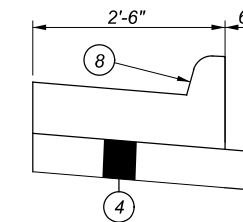

STEP DETAIL

LEGEND

- | | | |
|--|--|--|
| ① ITEM 441 1½" ASPHALT CONCRETE SURFACE COURSE, TYPE 1, (448), PG64-22 | ⑥ ITEM 407 | ⑪ ITEM 659 SEEDING AND MULCHING |
| ② ITEM 441 1¾" ASPHALT CONCRETE INTERMEDIATE COURSE, TYPE 2, (448) | ⑦ ITEM 407 TACK COAT (0.085 GAL/SY) | ⑫ ITEM 608 5" CONCRETE WALK |
| ③ ITEM 302 9" ASPHALT CONCRETE BASE, PG64-22 | ⑧ ITEM 609 COMBINATION CURB AND GUTTER, TYPE 2 | (A) EXISTING ASPHALT CONCRETE PAVEMENT |
| ④ ITEM 304 6" AGGREGATE BASE | ⑨ ITEM 605 4" SHALLOW PIPE UNDERDRAIN | |
| ⑤ ITEM 204 SUBGRADE COMPACTION | ⑩ ITEM 254 PAVEMENT PLANING, ASPHALT CONCRETE (1½" AT PROFILE GRADE) | |

UTILITIES

LISTED BELOW ARE ALL UTILITIES LOCATED WITHIN THE PROJECT CONSTRUCTION LIMITS TOGETHER WITH THEIR RESPECTIVE OWNERS:

| | |
|---|---|
| TIM MEYER DUKE ENERGY ELECTRIC RECORDS 2010 DANA AVE, EF324 CINCINNATI, OH 45207 | KYLE BUCKLEY GREATER CINCINNATI WATER WORKS 4747 SPRING GROVE AVE CINCINNATI, OH 45232 |
| BRIAN HOLLMANN DUKE ENERGY GAS RECORDS 139 E. FOURTH ST., RM. 460A CINCINNATI, OH 45202 | JOHN STRAUSS CINCINNATI BELL NETWORK OPERATIONS - SPECIALIST OUTSIDE PLANT ENGINEER 221 E. FOURTH ST. (BLDG. 121-900) CINCINNATI, OH 45201 |
| KENT RIEGER SPECTRUM CONSTRUCTION COORDINATOR 10920 KENWOOD ROAD CINCINNATI, OH 45242 | SARAH EMANS COMNET, INC PLANT GIS & DESIGN OSP MANAGER 13888 COUNTY ROAD 25A WAPAKONETA, OHIO |

THE LOCATION OF THE UNDERGROUND UTILITIES SHOWN ON THE PLANS ARE AS OBTAINED FROM THE OWNERS AS REQUIRED BY SECTION 153.64 O.R.C.

SURVEYING PARAMETERS

PRIMARY PROJECT CONTROL MONUMENTS GOVERN ALL POSITIONING ON ODOT PROJECTS. SEE BELOW FOR A TABLE CONTAINING PROJECT CONTROL INFORMATION.

USE THE FOLLOWING PROJECT CONTROL, VERTICAL POSITIONING, AND HORIZONTAL POSITIONING PARAMETERS FOR ALL SURVEYING:

PROJECT CONTROL

POSITIONING METHOD: ODOT VRS
 MONUMENT TYPE: TYPE 13

VERTICAL POSITIONING

ORTHOMETRIC HEIGHT DATUM: NAVD 88
 GEOID: GEOID 1213

HORIZONTAL POSITIONING

REFERENCE FRAME: NAD83 (2011)
 ELLIPSOID: GR580
 MAP PROJECTION: LAMBERT CONFORMAL CONIC
 COORDINATE SYSTEM: OHIO STATE PLANE, SOUTH ZONE
 COMBINED SCALE FACTOR: 1.00002576
 ORIGIN OF COORDINATE SYSTEM: 0,0

USE THE POSITIONING METHODS AND MONUMENT TYPE USED IN THE ORIGINAL SURVEY TO RESTORE ALL MONUMENTS RELATED TO PRIMARY PROJECT CONTROL THAT ARE DAMAGED OR DESTROYED BY CONSTRUCTION ACTIVITIES. RESTORE THE DAMAGED OR DESTROYED MONUMENTS IN ACCORDANCE WITH CMS 623.

UNITS ARE IN U.S. SURVEY FEET.

WORK LIMITS

THE WORK LIMITS SHOWN ON THESE PLANS ARE FOR PHYSICAL CONSTRUCTION ONLY. PROVIDE THE INSTALLATION AND OPERATION OF ALL WORK ZONE TRAFFIC CONTROL AND WORK ZONE TRAFFIC CONTROL DEVICES REQUIRED BY THESE PLANS WHETHER INSIDE OR OUTSIDE THESE WORK LIMITS.

CONSTRUCTION NOISE

ACTIVITIES AND LAND USE ADJACENT TO THIS PROJECT MAY BE AFFECTED BY CONSTRUCTION NOISE. IN ORDER TO MINIMIZE ANY ADVERSE CONSTRUCTION NOISE IMPACTS, DO NOT OPERATE POWER-OPERATED CONSTRUCTION-TYPE DEVICES BETWEEN THE HOURS OF 10 PM AND 6 AM. IN ADDITION, DO NOT OPERATE AT ANY TIME ANY DEVICE IN SUCH A MANNER THAT THE NOISE CREATED SUBSTANTIALLY EXCEEDS THE NOISE CUSTOMARILY AND NECESSARILY ATTENDANT TO THE REASONABLE AND EFFICIENT PERFORMANCE OF SUCH EQUIPMENT.

PART-WIDTH CONSTRUCTION

BECAUSE OF THE NECESSITY TO BUILD THIS PROJECT UNDER TRAFFIC AND TO CONSTRUCT THE FULL PAVEMENT WIDTH IN STAGES, EXERCISE CARE TO PREVENT THE CONSTRUCTION OF A BUTT JOINT IN THE BASE COURSES. LAP LONGITUDINAL JOINTS AS SHOWN ON STANDARD CONSTRUCTION DRAWING BP-3.1.

SEEDING AND MULCHING

THE FOLLOWING QUANTITIES ARE PROVIDED TO PROMOTE GROWTH AND CARE OF PERMANENT SEEDED AREAS:

| | |
|----------------------------|-------------|
| 659, TOPSOIL | 37 CU. YD. |
| 659, SEEDING AND MULCHING | 489 SQ. YD. |
| 659, COMMERCIAL FERTILIZER | 0.05 TON |
| 659, WATER | 1 M. GAL. |

SEEDING AND MULCHING SHALL BE APPLIED TO ALL AREAS OF EXPOSED SOIL BETWEEN THE RIGHT-OF-WAY LINES, AND WITHIN THE CONSTRUCTION LIMITS FOR AREAS OUTSIDE THE RIGHT-OF-WAY LINES COVERED BY WORK AGREEMENT OR SLOPE EASEMENT. QUANTITY CALCULATIONS FOR SEEDING AND MULCHING ARE BASED ON THESE LIMITS.

ITEM 202 - REMOVAL, MISC: LANDSCAPE WALL REMOVED

THE CONTRACTOR SHALL REMOVE LANDSCAPE WALL AT LOCATION SHOWN ON SHEET 9. REMOVAL SHALL BE PER ITEM 202. ALL MATERIALS, LABOR AND EQUIPMENT REQUIRED TO COMPLETE THE WORK DESCRIBED ABOVE SHALL BE INCLUDED UNDER THE UNIT BID PRICE FOR ITEM 202 - REMOVAL MISC.: LANDSCAPE WALL REMOVED

CROSSINGS AND CONNECTIONS TO EXISTING PIPES AND UTILITIES

WHERE PLANS PROVIDE FOR A PROPOSED CONDUIT TO BE CONNECTED TO, OR CROSS OVER OR UNDER AN EXISTING SEWER OR UNDERGROUND UTILITY, THE CONTRACTOR SHALL LOCATE THE EXISTING PIPES OR UTILITIES BOTH AS TO LINE AND GRADE BEFORE STARTING TO LAY THE PROPOSED CONDUIT.

IF IT IS DETERMINED THAT THE ELEVATION OF THE EXISTING CONDUIT, OR EXISTING APPURTENANCE TO BE CONNECTED, DIFFERS FROM THE PLAN ELEVATION OR RESULTS IN A CHANGE IN THE PLAN CONDUIT SLOPE, THE ENGINEER SHALL BE NOTIFIED BEFORE STARTING CONSTRUCTION OF ANY PORTION OF THE PROPOSED CONDUIT WHICH WILL BE AFFECTED BY THE VARIANCE IN THE EXISTING ELEVATIONS.

IF IT IS DETERMINED THAT THE PROPOSED CONDUIT WILL INTERSECT AN EXISTING SEWER OR UNDERGROUND UTILITY IF CONSTRUCTED AS SHOWN ON THE PLAN, THE ENGINEER SHALL BE NOTIFIED BEFORE STARTING CONSTRUCTION OF ANY PORTION OF THE PROPOSED CONDUIT WHICH WOULD BE AFFECTED BY THE INTERFERENCE WITH AN EXISTING FACILITY.

PAYMENT FOR ALL THE OPERATIONS DESCRIBED ABOVE SHALL BE INCLUDED IN THE CONTRACT PRICE FOR THE PERTINENT 611 CONDUIT ITEM.

MATERIAL STAGING AREA

THE CONTRACTOR MAY UTILIZE THE EXISTING NORTHBOUND LANES OF COLUMBIA ROAD AS A STAGING AREA DURING PERIODS WHEN THE NORTHBOUND LANES ARE CLOSED TO TRAFFIC. THE CONTRACTOR SHALL ENSURE THAT NO MATERIALS OR EQUIPMENT ENCROACH INTO THE SOUTHBOUND LANES.



ITEM 614 - MAINTAINING TRAFFIC

IT IS THE INTENTION TO PERFORM THE REQUIRED WORK WITH THE LEAST INCONVENIENCE TO, AND THE MAXIMUM SAFETY OF THE CONTRACTOR AND THE TRAVELING PUBLIC. THE REQUIREMENTS FOR MAINTAINING TRAFFIC AS SPECIFIED IN THE "OHIO MANUAL OF UNIFORM TRAFFIC CONTROL DEVICES, CURRENT EDITION", PERTINENT PROVISIONS OF THE "OHIO DEPARTMENT OF TRANSPORTATION CONSTRUCTION AND MATERIALS SPECIFICATIONS" (INCLUDING SUPPLEMENTAL SPECIFICATIONS) AND APPLICABLE STANDARD CONSTRUCTION DRAWINGS SHALL APPLY TO THIS PROJECT IN ADDITION TO THE FOLLOWING NOTES.

A MINIMUM OF ONE LANE OF TRAFFIC IN EACH DIRECTION SHALL BE MAINTAINED AT ALL TIMES, EXCEPT FOR A PERIOD NOT TO EXCEED 60 CONSECUTIVE CALENDAR DAYS, WHEN NORTHBOUND THROUGH TRAFFIC MAY BE DETOURED AS SHOWN ON SHEET 5.

ACCESS FOR ABUTTING PROPERTY OWNERS SHALL BE MAINTAINED AT ALL TIMES IN ACCORDANCE WITH THESE NOTES AND PLAN SPECIFICATIONS. THE CONTRACTOR SHALL WORK WITH THE PROPERTY OWNERS TO MAINTAIN SPECIAL ACCESS PROVISIONS.

LENGTH AND DURATION OF LANE CLOSURES AND RESTRICTIONS SHALL BE AT THE APPROVAL OF THE ENGINEER. IT IS THE INTENT TO MINIMIZE THE IMPACT TO THE TRAVELING PUBLIC. LANE CLOSURES OR RESTRICTIONS OVER SEGMENTS OF THE PROJECT IN WHICH NO WORK IS ANTICIPATED WITHIN A REASONABLE TIME FRAME, AS DETERMINED BY THE ENGINEER, SHALL NOT BE PERMITTED. THE LEVEL OF UTILIZATION OF MAINTENANCE OF TRAFFIC DEVICES SHALL COMMENSURATE WITH THE WORK IN PROGRESS.

LANE CLOSURES ARE NOT PERMITTED ON US 22/3 BETWEEN THE HOURS 12 P.M. AND 7 P.M.

NOTICE OF CLOSURE SIGNS (W20-H13) SHALL BE ERECTED BY THE CONTRACTOR PRIOR TO THE SCHEDULED ROAD CLOSURE IN ACCORDANCE WITH THE NOTICE OF CLOSURE TIME TABLE BELOW.

THE SIGNS SHALL BE ERECTED ON THE RIGHT-HAND SIDE OF THE ROAD FACING TRAFFIC. THEY SHALL BE PLACED SO AS NOT TO INTERFERE WITH THE VISIBILITY OF ANY OTHER TRAFFIC CONTROL DEVICES. THEY SHOULD BE ERECTED AT OR NEAR THE POINT OF CLOSURE.

| NOTICE TO CLOSURE SIGN TIME TABLE | | |
|-----------------------------------|------------------------|-----------------------------------|
| ITEM | DURATION OF CLOSURE | SIGN DISPLAYED TO PUBLIC |
| ROAD CLOSURE | >= 2 WEEKS | 14 CALENDAR DAYS PRIOR TO CLOSURE |
| | > 12 HOURS & < 2 WEEKS | 7 CALENDAR DAYS PRIOR TO CLOSURE |
| | < 12 HOURS | 2 CALENDAR DAYS PRIOR TO CLOSURE |

THE SIGN SHALL DISPLAY THE DATE OF THE CLOSURE IN MMM-DD FORMAT AND THE NUMBER OF DAYS OF THE CLOSURE. THE LAST LINE OF THE W0-H13 SIGN LISTS A PHONE NUMBER WHICH A MOTORIST MAY CALL FOR ADDITIONAL INFORMATION. THIS IS TO BE A SPECIFIC OFFICE WITHIN THE COUNTY RATHER THAN THE GENERAL SWITCHBOARD NUMBER.

THE CONTRACTOR SHALL PROVIDE ONE-WAY SIGNS (R6-1L OR 1R) AT THE EXIT OF EACH DRIVE ON COLUMBIA ROAD, DIRECTING TRAFFIC TO THE SOUTH. THE SIGN SHALL BE 36 X 12 INCH IN SIZE WITH TYPE G OR TYPE H ORANGE RETROREFLECTIVE SHEETING.

ITEM 614 - MAINTAINING TRAFFIC (CONT.)

THE SIGNS SHALL BE MOUNTED ON TWO #3 POSTS OR ON TEMPORARY POSTS IN ACCORDANCE WITH SCD MT-105.10 AND IN ACCORDANCE WITH THE OHIO MANUAL OF UNIFORM TRAFFIC CONTROL DEVICES, CURRENT EDITION. THE SIGN SHALL BE CLEARLY VISIBLE AND SHALL CLEARLY IDENTIFY THE LOCATION OF THE DRIVEWAY. THE SIGN SHOULD BE POSITIONED AT 90 DEGREES TO THE DIRECTION(S) OF TRAFFIC. THE SIGN MAY NEED TO BE MOVED FOR EACH PHASE OF THE MAINTENANCE OF TRAFFIC OPERATIONS.

THE CONTRACTOR SHALL PROVIDE, ERECT AND MAINTAIN STANDARD 48 x 30 INCH ROAD CLOSED SIGNS, SIGN SUPPORTS, BARRICADES AND LIGHTS, AS DETAILED IN SCD MT-101.60 AT THE LOCATIONS DESCRIBED IN THESE NOTES DURING PERIODS IN WHICH THE AFFECTED ROADS ARE CLOSED TO TRAFFIC.

THE CONTRACTOR SHALL PROVIDE, ERECT AND MAINTAIN SIGNS AND SIGN SUPPORTS, AS DETAILED IN THE OHIO MANUAL OF UNIFORM TRAFFIC CONTROL DEVICES, AND TYPE III BARRICADES OF THE TYPE AND LOCATION SHOWN IN THE DETOUR PLAN.

ALL WORK AND TRAFFIC CONTROL DEVICES SHALL BE IN ACCORDANCE WITH C&MS 614 AND OTHER APPLICABLE PORTIONS OF THE SPECIFICATIONS, AS WELL AS THE OHIO MANUAL OF UNIFORM TRAFFIC CONTROL DEVICES. PAYMENT FOR ALL LABOR, EQUIPMENT AND MATERIALS SHALL BE INCLUDED IN THE LUMP SUM CONTRACT PRICE FOR ITEM 614 - MAINTAINING TRAFFIC, UNLESS SEPARATELY ITEMIZED IN THE PLAN.

NOTIFICATION OF TRAFFIC RESTRICTIONS

THROUGHOUT THE DURATION OF THE PROJECT, THE CONTRACTOR SHALL NOTIFY THE PROJECT ENGINEER IN WRITING OF ALL TRAFFIC RESTRICTIONS AND UPCOMING MAINTENANCE OF TRAFFIC CHANGES. THE CONTRACTOR SHALL ENSURE THE WRITTEN NOTIFICATION IS SUBMITTED IN A TIMELY MANNER TO ALLOW THE PROJECT ENGINEER TO MEET THE REQUIRED TIME FRAMES SET FORTH IN THE TABLE BELOW TO INFORM THE SPECIAL HAULING PERMITS SECTION (HAULING.PERMITS@DOT.OHIO.GOV) AND THE DISTRICT PUBLIC INFORMATION OFFICE (PIO). THIS NOTIFICATION SHALL BE RECEIVED BY THE PROJECT ENGINEER PRIOR TO THE PHYSICAL SETUP OF ANY APPLICABLE SIGNS OR MESSAGE BOARDS.

INFORMATION SHOULD INCLUDE, BUT IS NOT LIMITED TO, ALL CONSTRUCTION ACTIVITIES THAT IMPACT OR INTERFERE WITH TRAFFIC AND SHALL LIST THE SPECIFIC LOCATION, TYPE OF WORK, ROAD STATUS, DATE AND TIME OF RESTRICTION, DURATION OF RESTRICTION, NUMBER OF LANES MAINTAINED, NUMBER OF LANES CLOSED, MINIMUM VERTICAL CLEARANCE, MINIMUM WIDTH OF DRIVABLE PAVEMENT, DETOUR ROUTES, IF APPLICABLE, AND ANY OTHER INFORMATION REQUESTED BY THE PROJECT ENGINEER.

| NOTIFICATION TIME TABLE | | |
|------------------------------|------------------------|--|
| ITEM | DURATION OF CLOSURE | SIGN DISPLAYED TO PUBLIC |
| ROAD CLOSURE | >= 2 WEEKS | 14 CALENDAR DAYS PRIOR TO CLOSURE |
| | > 12 HOURS & < 2 WEEKS | 7 CALENDAR DAYS PRIOR TO CLOSURE |
| | < 12 HOURS | 2 CALENDAR DAYS PRIOR TO CLOSURE |
| LANE CLOSURES & RESTRICTIONS | >= 2 WEEKS | 14 CALENDAR DAYS PRIOR TO CLOSURE |
| | < 2 WEEKS | 5 CALENDAR DAYS PRIOR TO CLOSURE |
| LANE CLOSURES & RESTRICTIONS | N/A | 14 CALENDAR DAYS PRIOR TO IMPLEMENTATION |

ANY UNFORESEEN CONDITIONS NOT SPECIFIED IN THE PLANS REQUIRING TRAFFIC RESTRICTIONS SHALL ALSO BE REPORTED TO THE PROJECT ENGINEER USING THE NOTIFICATION TIME TABLE.

ITEM 614 - BUSINESS ENTRANCE (M4-H15) SIGN, AS PER PLAN

THE CONTRACTOR SHALL PROVIDE A BUSINESS ENTRANCE SIGN (M4-H15) AT THE STRIP MALL ENTRANCE DRIVE, LOCATED JUST SOUTH OF THE BEGINNING OF THE FULL-DEPTH PAVEMENT REPLACEMENT. ONLY ONE SIGN PER BUSINESS SHALL BE PERMITTED. THE SIGN SHALL BE 36 x 48 INCH IN SIZE WITH TYPE G OR TYPE H ORANGE RETROREFLECTIVE SHEETING. THE SIGN LEGEND SHALL BE PLACED ON BOTH SIDES OF THE SIGN (BACK TO BACK). THE SIGN SHALL HAVE THE STANDARD M4-H15 LEGEND WITH THE WORD "BUSINESS" ON THE TOP LINE, EXCEPT UNDER UNUSUAL CIRCUMSTANCES WHERE IT MAY NOT BE INTUITIVE THAT A DRIVEWAY SERVES A SPECIFIC BUSINESS. IN SUCH UNUSUAL CASES, THE ACTUAL BUSINESS NAME MAY BE SUBSTITUTED FOR THE WORD "BUSINESS".

THE SIGNS SHALL BE MOUNTED ON TWO #3 POSTS OR ON TEMPORARY POSTS IN ACCORDANCE WITH SCD MT-105.10 AND IN ACCORDANCE WITH THE OHIO MANUAL OF UNIFORM TRAFFIC CONTROL DEVICES, CURRENT EDITION. THE SIGN SHALL BE CLEARLY VISIBLE AND SHALL CLEARLY IDENTIFY THE LOCATION OF THE DRIVEWAY. THE SIGN SHOULD BE POSITIONED AT 90 DEGREES TO THE DIRECTION(S) OF TRAFFIC. THE SIGN MAY NEED TO BE MOVED FOR EACH PHASE OF THE MAINTENANCE OF TRAFFIC OPERATIONS.

PAYMENT FOR ALL COSTS ASSOCIATED WITH MANUFACTURING, MOUNTING, RELOCATING, AND REMOVING THE SIGN, INCLUDING ALL LABOR, MATERIALS AND EQUIPMENT SHALL BE INCLUDED IN THE CONTRACT PRICE PER EACH FOR ITEM 614 - BUSINESS ENTRANCE SIGN.

THE FOLLOWING ESTIMATED QUANTITY HAS BEEN CARRIED TO THE GENERAL SUMMARY FOR THIS ITEM:

ITEM 614 - BUSINESS ENTRANCE SIGN 1 EACH

ITEM 614 - DETOUR SIGNING

THE CONTRACTOR SHALL FURNISH, ERECT, MAINTAIN AND REMOVE DETOUR SIGNING. PAYMENT FOR ALL MATERIAL, LABOR AND EQUIPMENT TO IMPLEMENT THE DETOUR SIGNING SHALL BE INCLUDED IN THE LUMP SUM BID FOR ITEM 614 - DETOUR SIGNING.

| | |
|---|-------------|
| DESIGN AGENCY | |
|  | |
| DESIGNER | DMG |
| REVIEWER | |
| BAA | 06-28-21 |
| PROJECT ID | COLUMBIA RD |
| SHEET | TOTAL |
| 4 | 24 |

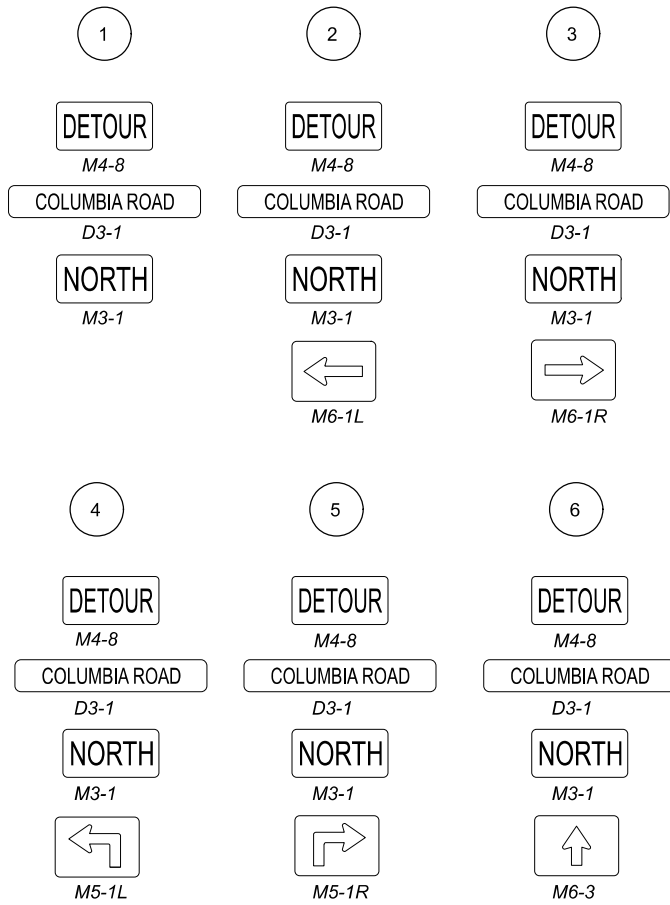

7
TYPE B WARNING LIGHT



OPEN TO ADDRESS
8972

ROAD CLOSED
1.0 MILES AHEAD
LOCAL TRAFFIC ONLY

R11-3A



M5-1L

TYPE III BARRICADE

11
ROAD CLOSED AHEAD



W20-3

500 FEET

W16-2

8
TYPE B WARNING LIGHT

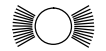

DETOUR AHEAD

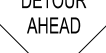

W20-2

12
TYPE A WARNING LIGHT

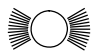

ROAD CLOSED AHEAD



W20-3

1000 FEET

W16-2

9
END DETOUR

M4-8A

10
TYPE A WARNING LIGHT

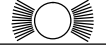

OPEN TO ADDRESSES
8972-8976

ROAD CLOSED
LOCAL TRAFFIC ONLY

R11-2

TYPE III BARRICADE

14
OPEN TO ADDRESS
8972

ROAD CLOSED
XX MILES AHEAD
LOCAL TRAFFIC ONLY



ROAD CLOSED
XX MILES AHEAD
LOCAL TRAFFIC ONLY

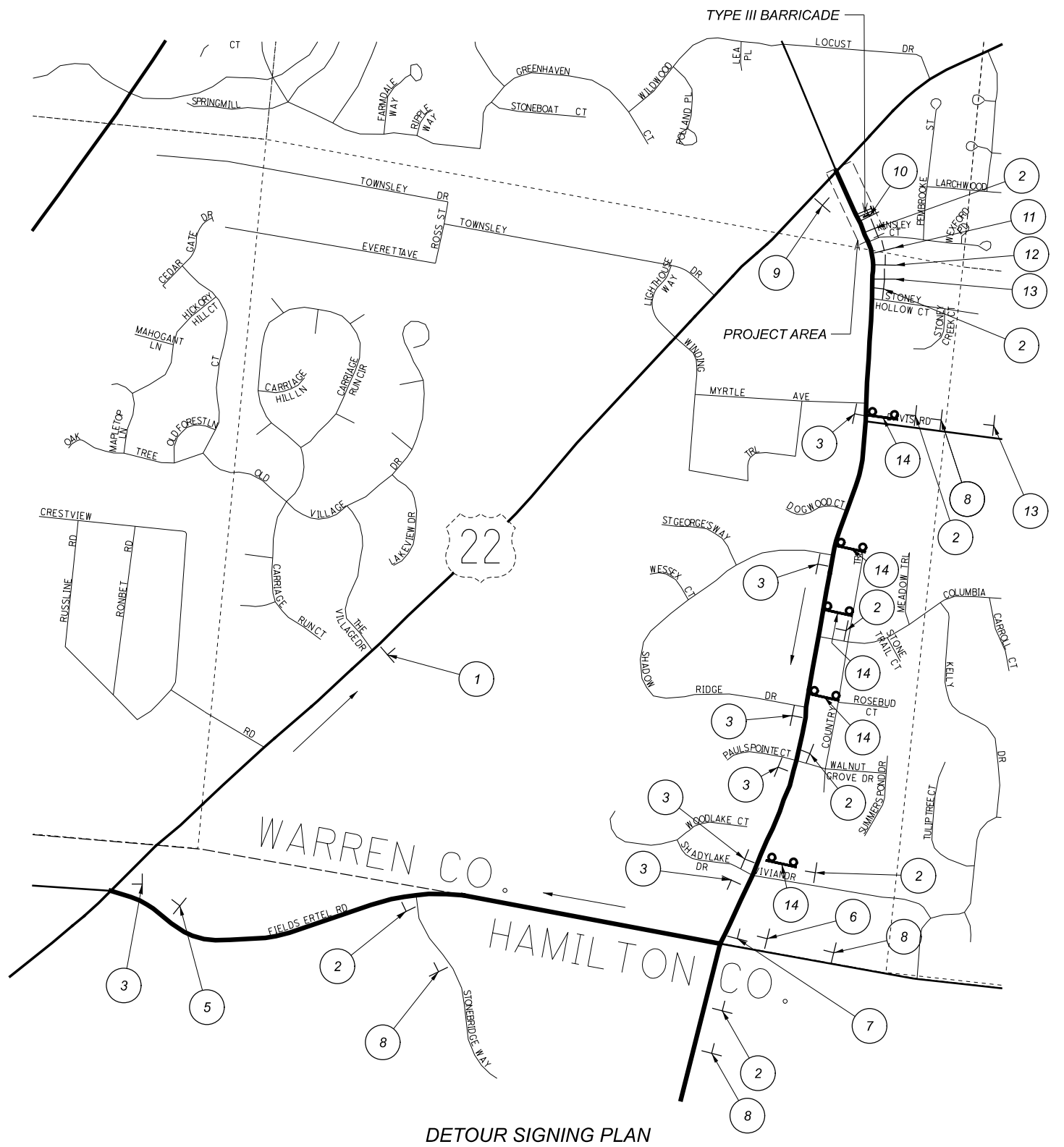

DETOUR SIGNING PLAN

| SHEET NUM. | | | | | | | | | | | | PART. | ITEM | ITEM | GRAND | UNIT | DESCRIPTION | SEE SHEET NO. |
|-------------------------------|--|--|--|--|--|--|--|--|---|-----|--------|-------|-------|-------|-------|--|-------------|---------------|
| | | | | | | | | | 4 | 18 | OFFICE | | EXT | TOTAL | | | | |
| TRAFFIC SIGNALS | | | | | | | | | | | | | | | | | | |
| | | | | | | | | | | 1 | | 632 | 05086 | 1 | EACH | VEHICULAR SIGNAL HEAD, (LED), 5-SECTION, 12" LENS, 1-WAY, POLYCARBONATE, BLACK | | |
| | | | | | | | | | | 1 | | 632 | 25000 | 1 | EACH | COVERING OF VEHICULAR SIGNAL HEAD | | |
| | | | | | | | | | | 282 | | 632 | 40700 | 282 | FT | SIGNAL CABLE, 7 CONDUCTOR, NO. 14 AWG | | |
| | | | | | | | | | | 1 | | 632 | 90100 | 1 | EACH | REMOVAL OF TRAFFIC SIGNAL INSTALLATION, AS PER PLAN | 18 | |
| | | | | | | | | | | 303 | | 632 | 90500 | 303 | FT | SIGNALIZATION, MISC.: UNLASH AND RELASH MESSENGER WIRE | 18 | |
| | | | | | | | | | | 2 | | 809 | 69100 | 2 | EACH | STOP LINE RADAR DETECTION, AS PER PLAN | 18 | |
| MAINTENANCE OF TRAFFIC | | | | | | | | | | | | | | | | | | |
| | | | | | | | | | 1 | | | 614 | 12420 | LS | | DETOUR SIGNING | | |
| | | | | | | | | | 1 | | | 614 | 40051 | 1 | EACH | BUSINESS ENTRANCE SIGN, AS PER PLAN | 4 | |
| INCIDENTALS | | | | | | | | | | | | | | | | | | |
| | | | | | | | | | | | | 614 | 11000 | LS | | MAINTAINING TRAFFIC | | |
| | | | | | | | | | | | | 624 | 10000 | LS | | MOBILIZATION | | |
| | | | | | | | | | | | | 623 | 10000 | LS | | CONSTRUCTION LAYOUT STAKES AND SURVEYING | | |
| | | | | | | | | | | | | 832 | 30000 | 5,000 | EACH | EROSION CONTROL | | |

GENERAL SUMMARY

DESIGN AGENCY

 DESIGNER
 BTP
 REVIEWER
 BAA 06/28/21
 PROJECT ID
 COLUMBIA RD
 SHEET TOTAL
 7 24

| REF NO. | SHEET NO. | STATION TO STATION | | | 202 | 202 | 202 | 202 | 202 | 202 | 605 | 608 | 611 | 611 | 611 | 611 | 621 | 611 | | | | | | | | | | | | | | | | | | | | |
|-----------------------------------|-----------|--------------------|----|---------|--------------------|-----------------------------|------------------------|--------------------|--------------------|---|-----------------------------------|-----------------|---|-----------------------------|---------------------------|-----------------------------------|---|---------------------------|--|--|--|--|--|--|--|--|--|--|--|--|--|--|--|--|--|--|--|--|
| | | | | | PIPE REMOVED FT | CATCH BASIN REMOVED EACH | PAVEMENT REMOVED SY | CURB REMOVED FT | WALK REMOVED SF | REMOVAL MISC.:LANDSCAPE WALL REMOVED FT | 4" SHALLOW PIPE UNDERDRAINS FT | CURB RAMP SF | 4" CONDUIT, TYPE F FOR UNDERDRAIN OUTLET FT | CATCH BASIN, NO. 3A EACH | 12" CONDUIT, TYPE B FT | MANHOLE ADJUSTED TO GRADE EACH | RAISED PAVEMENT MARKER REMOVED EACH | 12" CONDUIT, TYPE C FT | | | | | | | | | | | | | | | | | | | | |
| R1 | 9 | 8+60.95 | TO | 8+82.72 | 27 | 1 | | | | | | | | | | | | | | | | | | | | | | | | | | | | | | | | |
| R2 | 9 | 8+79.86 | TO | 8+82.72 | 37 | 1 | | | | | | | | | | | | | | | | | | | | | | | | | | | | | | | | |
| R3 | 9 | 5+60.00 | TO | 9+41.37 | | | 321 | | | | | | | | | | | | | | | | | | | | | | | | | | | | | | | |
| R4 | 9 | 5+60.00 | TO | 8+54.70 | | | | 304 | | | | | | | | | | | | | | | | | | | | | | | | | | | | | | |
| R5 | 9 | 8+26.74 | TO | 8+80.74 | | | | 91 | | | | | | | | | | | | | | | | | | | | | | | | | | | | | | |
| R6 | 9 | 8+84.69 | TO | 9+81.81 | | | | 145 | | | | | | | | | | | | | | | | | | | | | | | | | | | | | | |
| R7 | 9 | 9+40.13 | TO | 9+75.88 | | | | | 459 | | | | | | | | | | | | | | | | | | | | | | | | | | | | | |
| R8 | 3 | 9+47.67 | TO | 9+73.41 | | | | | | 42 | | | | | | | | | | | | | | | | | | | | | | | | | | | | |
| R9 | 9 | 5+92.48 | | | | | | | | | | | | | 1 | | | | | | | | | | | | | | | | | | | | | | | |
| R10 | 9 | 7+55.44 | | | | | | | | | | | | | 1 | | | | | | | | | | | | | | | | | | | | | | | |
| R11 | 9 | 9+16.84 | | | | | | | | | | | | | 1 | | | | | | | | | | | | | | | | | | | | | | | |
| R12 | 9 | 9+27.74 | | | | | | | | | | | | | 1 | | | | | | | | | | | | | | | | | | | | | | | |
| R13 | 9 | 5+60.00 | TO | 9+17.15 | | | | | | | | | | | | 16 | | | | | | | | | | | | | | | | | | | | | | |
| R14 | 9 | 5+58.23 | | | | | | | | | | | | | | | | | | | | | | | | | | | | | | | | | | | | |
| R15 | 9 | 6+75.40 | | | | | | | | | | | | | | | | | | | | | | | | | | | | | | | | | | | | |
| R16 | 9 | 9+35.92 | | | | | | | | | | | | | | | | | | | | | | | | | | | | | | | | | | | | |
| R17 | 9 | 8+76.27 | | | | | | | | | | | | | | | | | | | | | | | | | | | | | | | | | | | | |
| R18 | 9 | 9+65.43 | | | | | | | | | | | | | | | | | | | | | | | | | | | | | | | | | | | | |
| R19 | 9 | 3+96.87 | TO | 4+07.09 | | | | | | | | 31 | | | | | | | | | | | | | | | | | | | | | | | | | | |
| R20 | 9 | 9+47.95 | TO | 9+63.09 | | | | | | | | 45 | | | | | | | | | | | | | | | | | | | | | | | | | | |
| R21 | 9 | 9+63.09 | TO | 9+76.57 | | | | | | | | 44 | | | | | | | | | | | | | | | | | | | | | | | | | | |
| R22 | 9 | 3+48.80 | TO | 9+72.42 | | | | | | | | | | | | | | | | | | | | | | | | | | | | | | | | | | |
| D1 | 9 | 8+58.66 | TO | 8+82.60 | | | | | | | | | 1 | | | | | | | | | | | | | | | | | | | | | | | | | |
| D2 | 9 | 8+82.60 | TO | 8+82.90 | | | | | | | | | 1 | 48 | | | | | | | | | | | | | | | | | | | | | | | | |
| UD1 | 9 | 8+82.60 | | | | | | | | 257 | | 10 | | | | | | | | | | | | | | | | | | | | | | | | | | |
| UD2 | 9 | 8+82.60 | | | | | | | | 97 | | 10 | | | | | | | | | | | | | | | | | | | | | | | | | | |
| TOTALS CARRIED TO GENERAL SUMMARY | | | | | 64 | 2 | 321 | 540 | 459 | 42 | 354 | 120 | 20 | 2 | 48 | 4 | 16 | 23 | | | | | | | | | | | | | | | | | | | | |

ROADWAY SUBSUMMARY

DESIGN AGENCY

 DESIGNER
 BTP
 REVIEWER
 BAA 06/28/21
 PROJECT ID
 COLUMBIA RD
 SHEET TOTAL
 8 24

PROPOSED DRAINAGE STRUCTURES

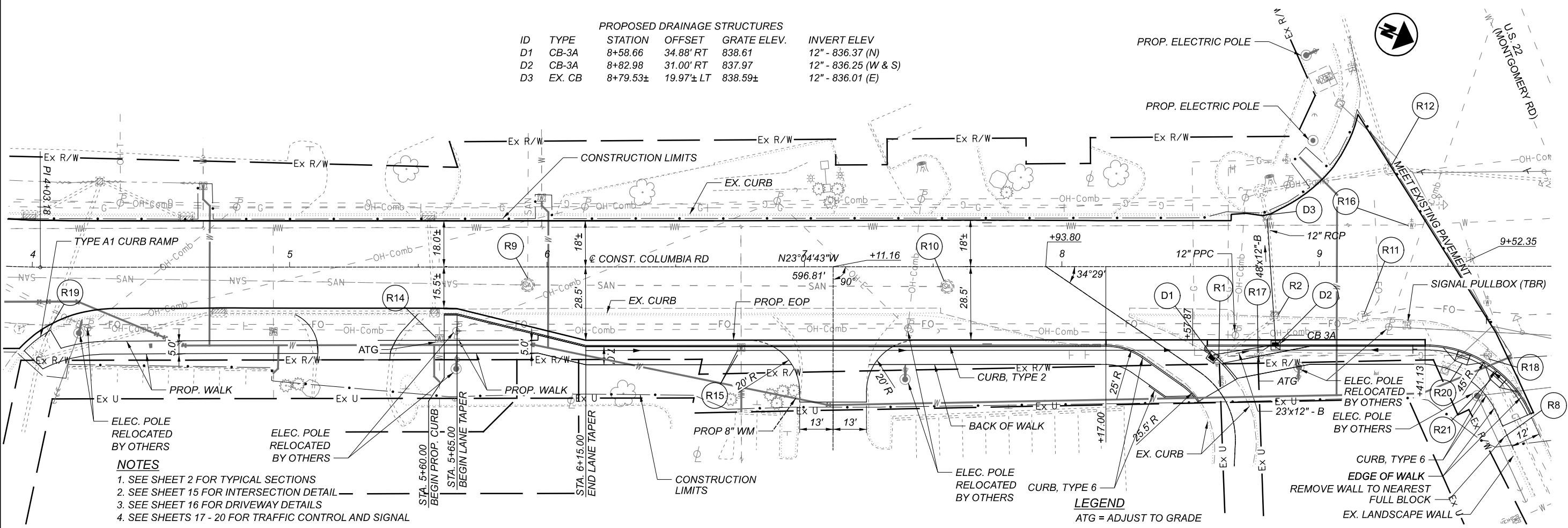
| ID | TYPE | STATION | OFFSET | GRATE ELEV. | INVERT ELEV. |
|----|--------|----------|-----------|-------------|----------------------|
| D1 | CB-3A | 8+58.66 | 34.88' RT | 838.61 | 12" - 836.37 (N) |
| D2 | CB-3A | 8+82.98 | 31.00' RT | 837.97 | 12" - 836.25 (W & S) |
| D3 | EX. CB | 8+79.53± | 19.97± LT | 838.59± | 12" - 836.01 (E) |



- NOTES**
1. SEE SHEET 2 FOR TYPICAL SECTIONS
 2. SEE SHEET 15 FOR INTERSECTION DETAIL
 3. SEE SHEET 16 FOR DRIVEWAY DETAILS
 4. SEE SHEETS 17 - 20 FOR TRAFFIC CONTROL AND SIGNAL

LEGEND
 ATG = ADJUST TO GRADE

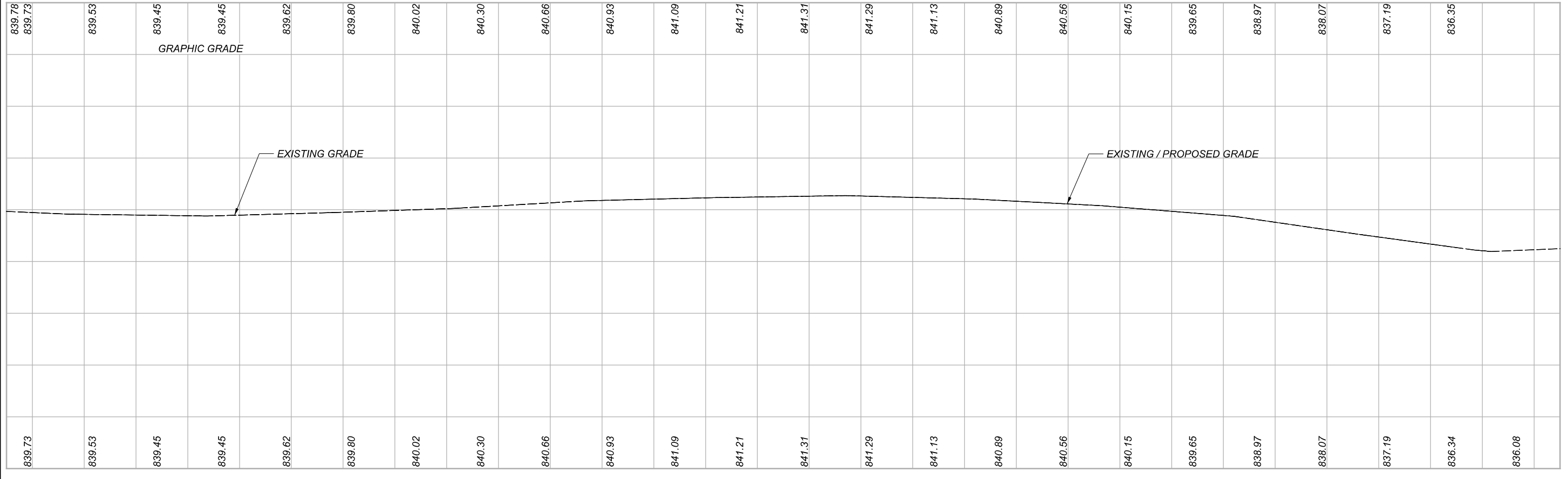

PLAN AND PROFILE
 COLUMBIA ROAD

DESIGN AGENCY
CARPENTER MARTY
 DESIGNER
 DMG
 REVIEWER
 BAA 06/28/21
 PROJECT ID
 COLUMBIA RD
 SHEET TOTAL
 9 24

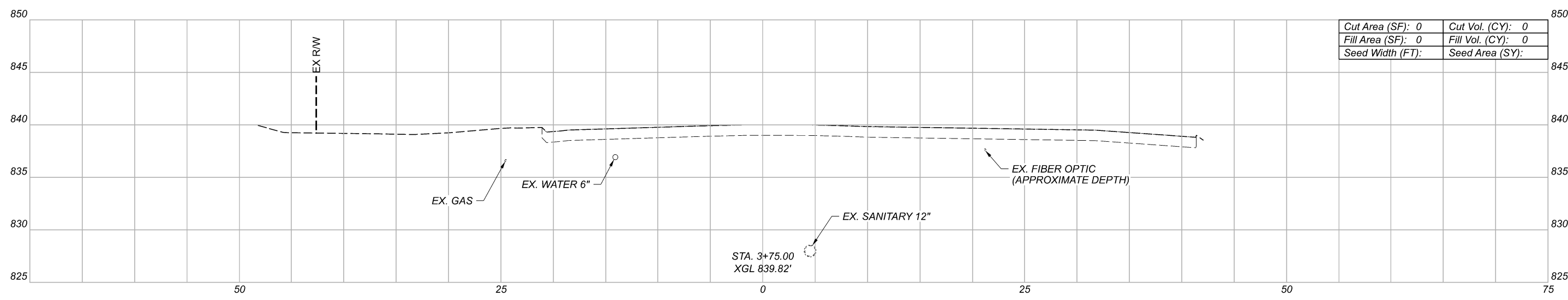
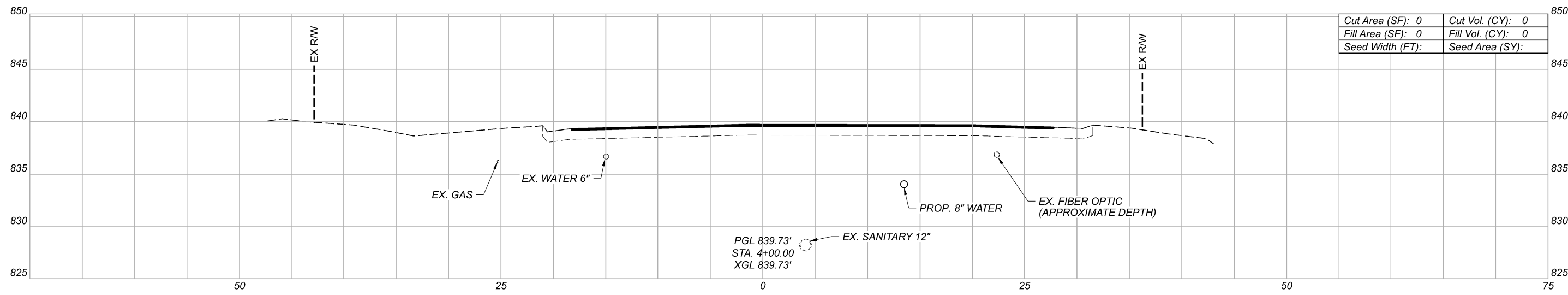
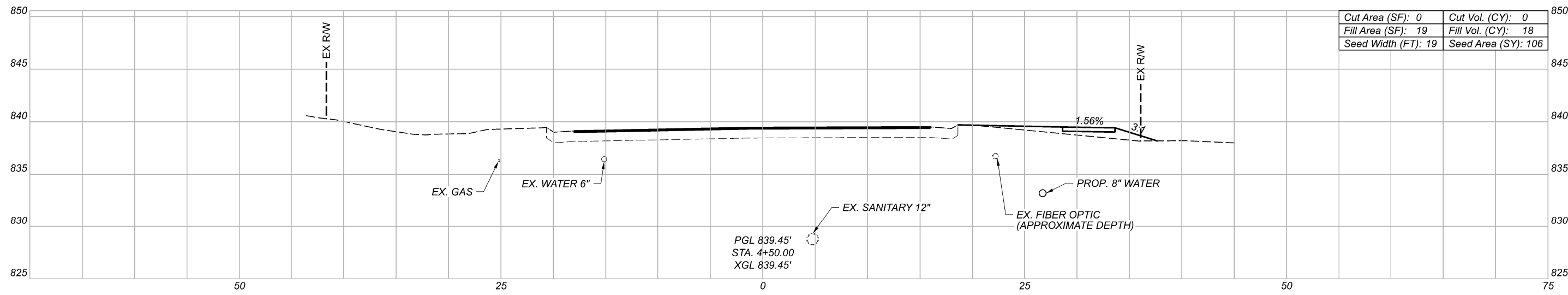

CROSS SECTIONS
 STA. 3+75 TO STA. 4+50

DESIGN AGENCY

 CARPENTER MARTY
 DESIGNER
 WCS
 REVIEWER
 BAA 06/28/21
 PROJECT ID
 COLUMBIA RD

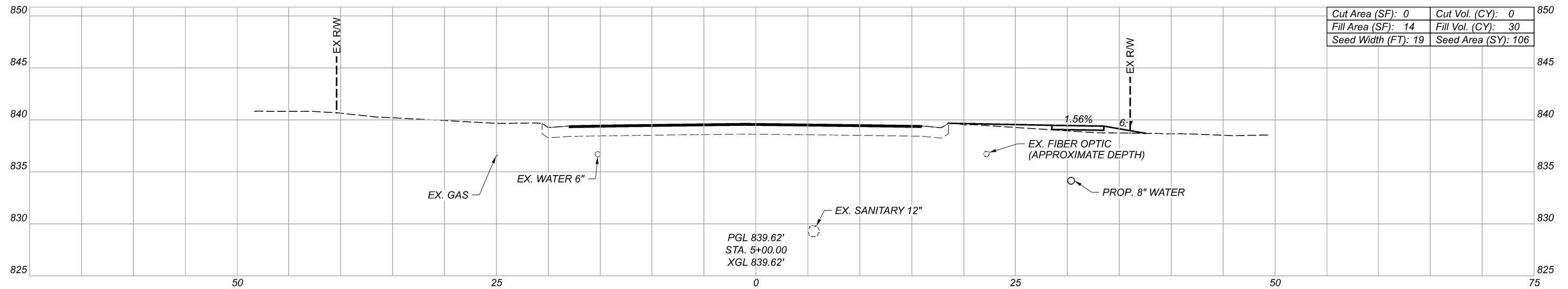
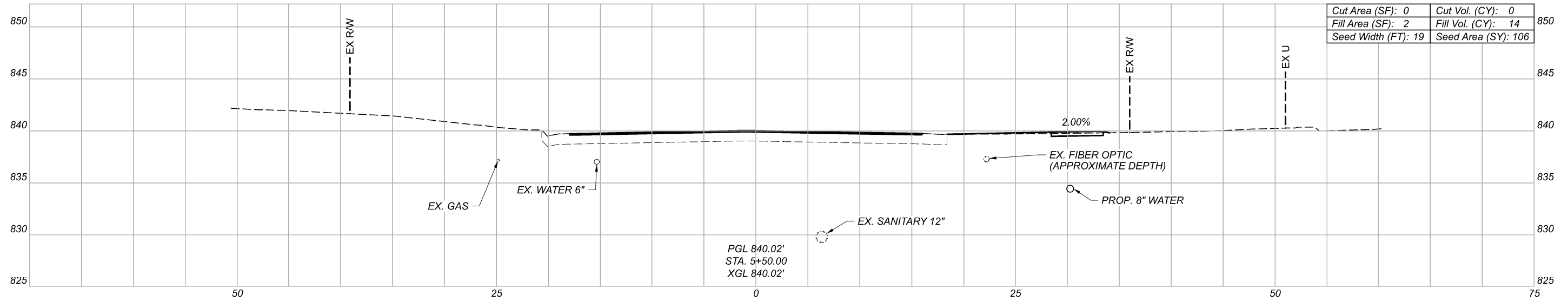
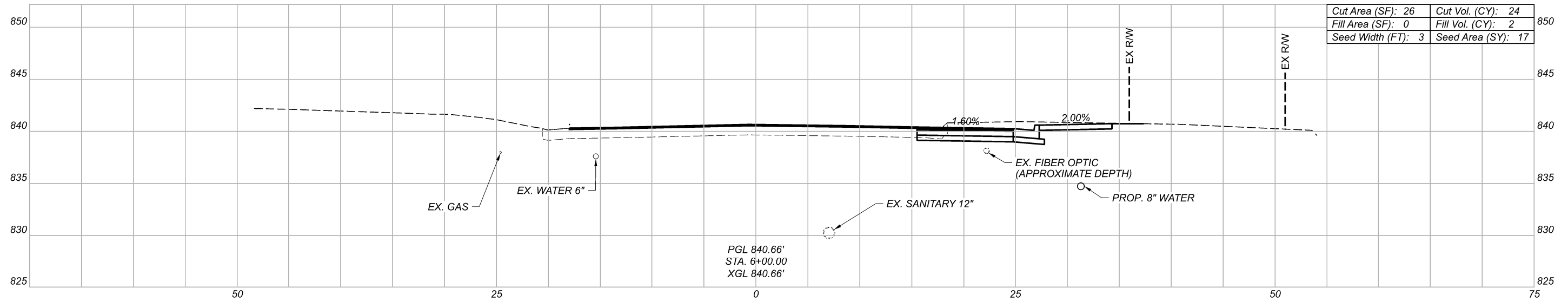
| Sheet Totals | | | SHEET | TOTAL |
|--------------|-----|------|-------|-------|
| Seeding | Cut | Fill | | |
| 106 | 0 | 18 | 10 | 24 |



CROSS SECTIONS
 STA. 5+00 TO 6+00



DESIGNER
 WCS
 REVIEWER
 BAA 06/28/21
 PROJECT ID
 COLUMBIA RD

| Sheet Totals | | | SHEET | TOTAL |
|--------------|-----|------|-------|-------|
| Seeding | Cut | Fill | | |
| 229 | 24 | 46 | 11 | 24 |

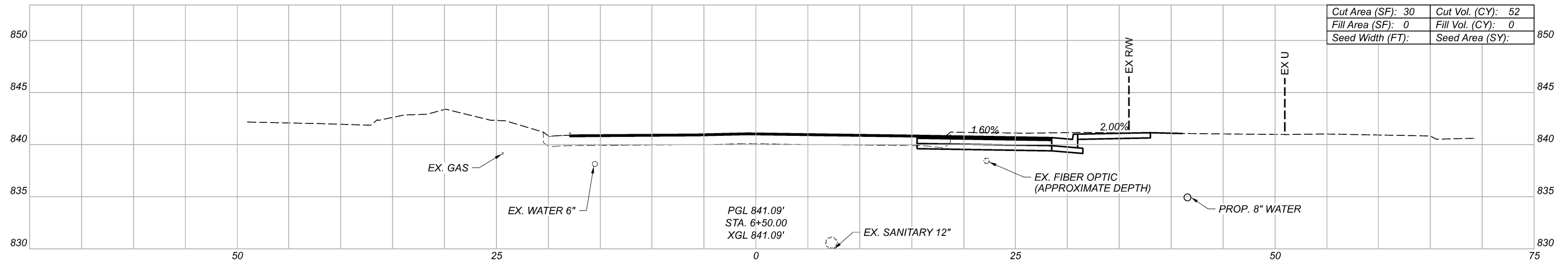
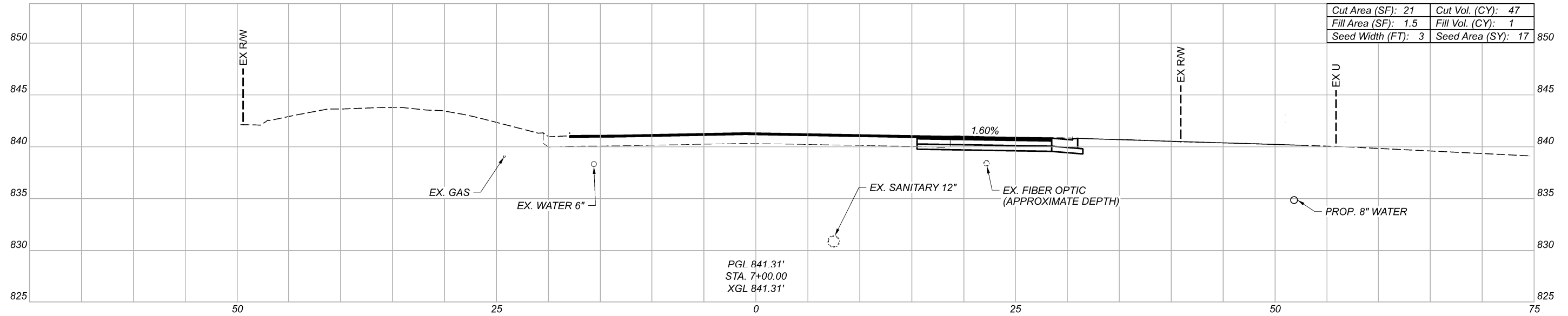
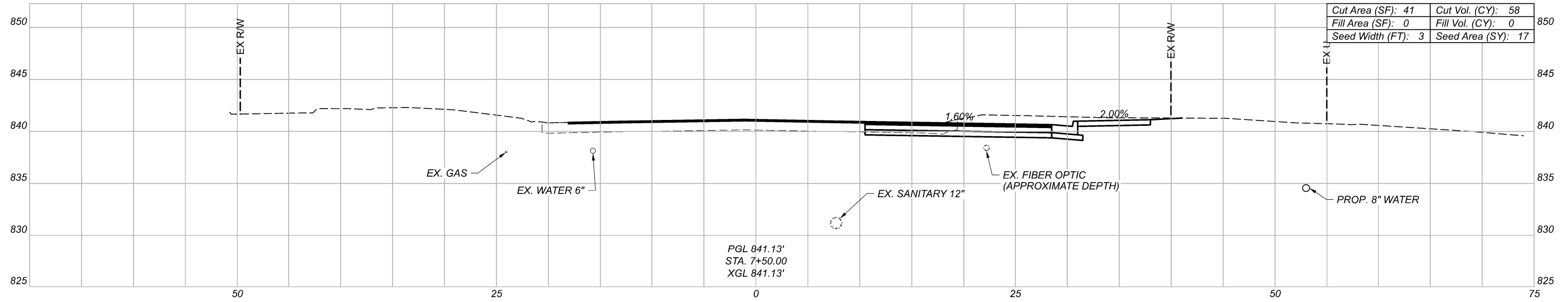

CROSS SECTIONS
 STA. 6+50 TO STA. 7+50

DESIGN AGENCY

 CARPENTER
 MARTY

DESIGNER
 WCS

REVIEWER
 BAA 06/28/21

PROJECT ID
 COLUMBIA RD

| Sheet Totals | | | SHEET | TOTAL |
|--------------|-----|------|-------|-------|
| Seeding | Cut | Fill | | |
| 34 | 157 | 1 | 12 | 24 |

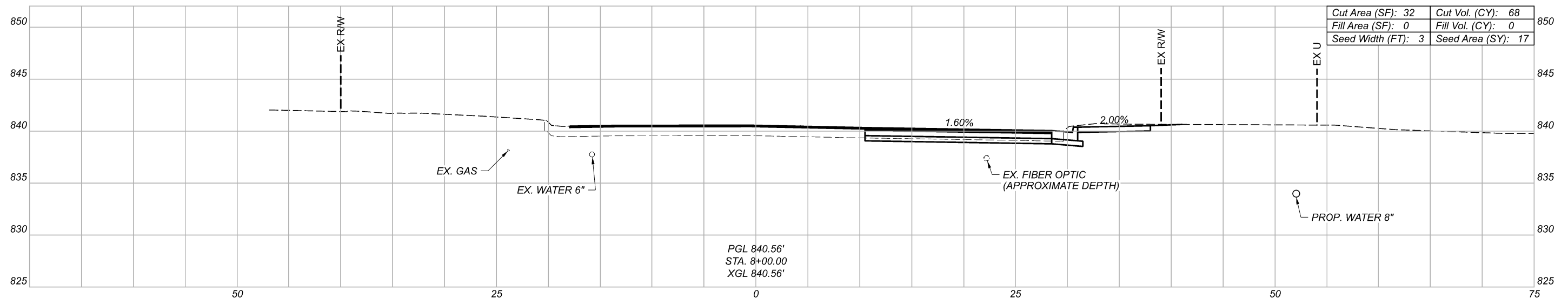
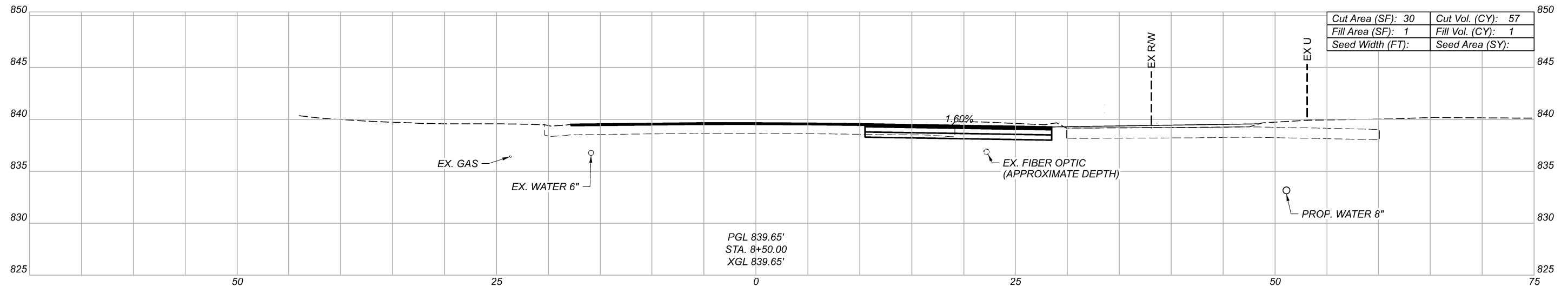
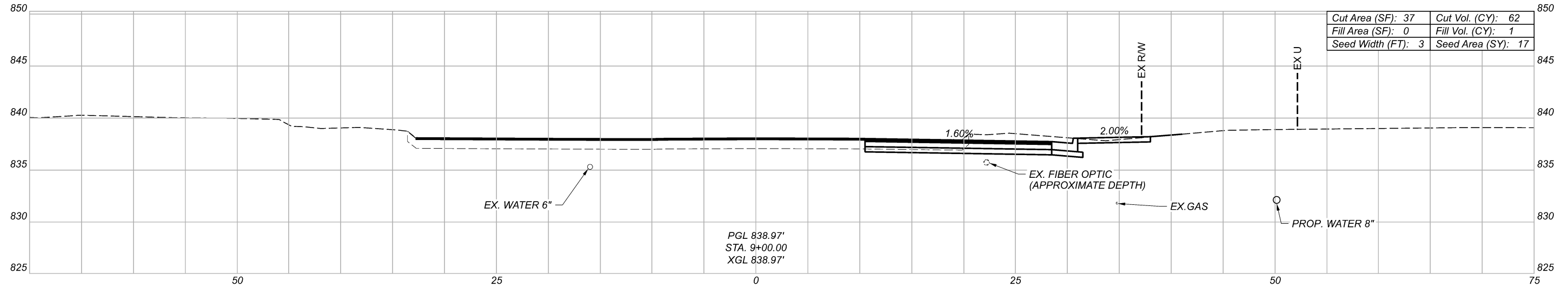

CROSS SECTIONS
 STA. 8+00 TO STA. 9+00



DESIGNER
 WCS

REVIEWER
 BAA 06/28/21

PROJECT ID
 COLUMBIA RD

| Sheet Totals | | | SHEET | TOTAL |
|--------------|-----|------|-------|-------|
| Seeding | Cut | Fill | | |
| 34 | 187 | 2 | 13 | 24 |

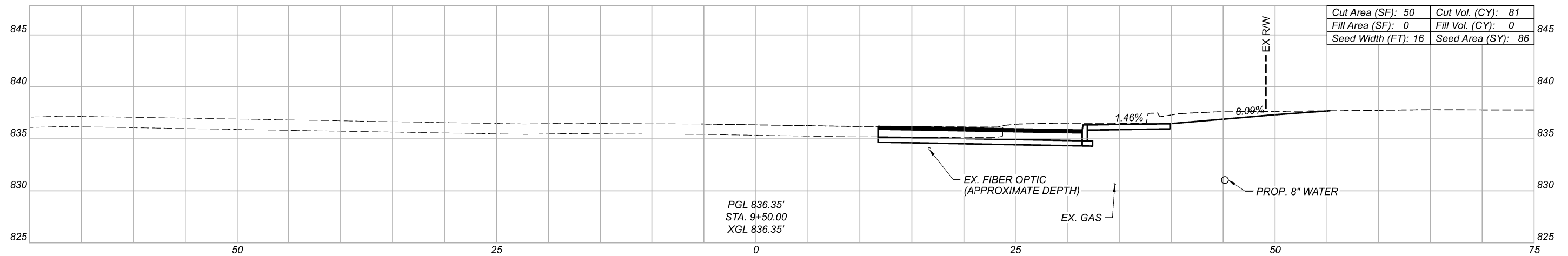

PGL 836.35'
 STA. 9+50.00
 XGL 836.35'

EX. FIBER OPTIC
 (APPROXIMATE DEPTH)

EX. GAS

PROP. 8" WATER

| Sheet Number | Earthwork Totals | | |
|-----------------------------------|------------------|----------|-----------|
| | Seeding (SY) | Cut (CY) | Fill (CY) |
| 10 | 106 | 0 | 18 |
| 11 | 229 | 24 | 46 |
| 12 | 34 | 157 | 1 |
| 13 | 34 | 187 | 2 |
| 14 | 86 | 81 | 0 |
| Totals Carried to General Summary | 489 | 449 | 67 |

| | |
|---------------------|--------------------|
| Cut Area (SF): 50 | Cut Vol. (CY): 81 |
| Fill Area (SF): 0 | Fill Vol. (CY): 0 |
| Seed Width (FT): 16 | Seed Area (SY): 86 |

| Sheet Totals | | | SHEET | TOTAL |
|--------------|-----|------|-------|-------|
| Seeding | Cut | Fill | | |
| 86 | 81 | 0 | 14 | 24 |

DESIGN AGENCY

 CARPENTER MARTY
 ENGINEERING
 DESIGNER
 WCS
 REVIEWER
 BAA 06/28/21
 PROJECT ID
 COLUMBIA RD

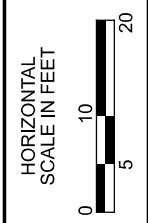
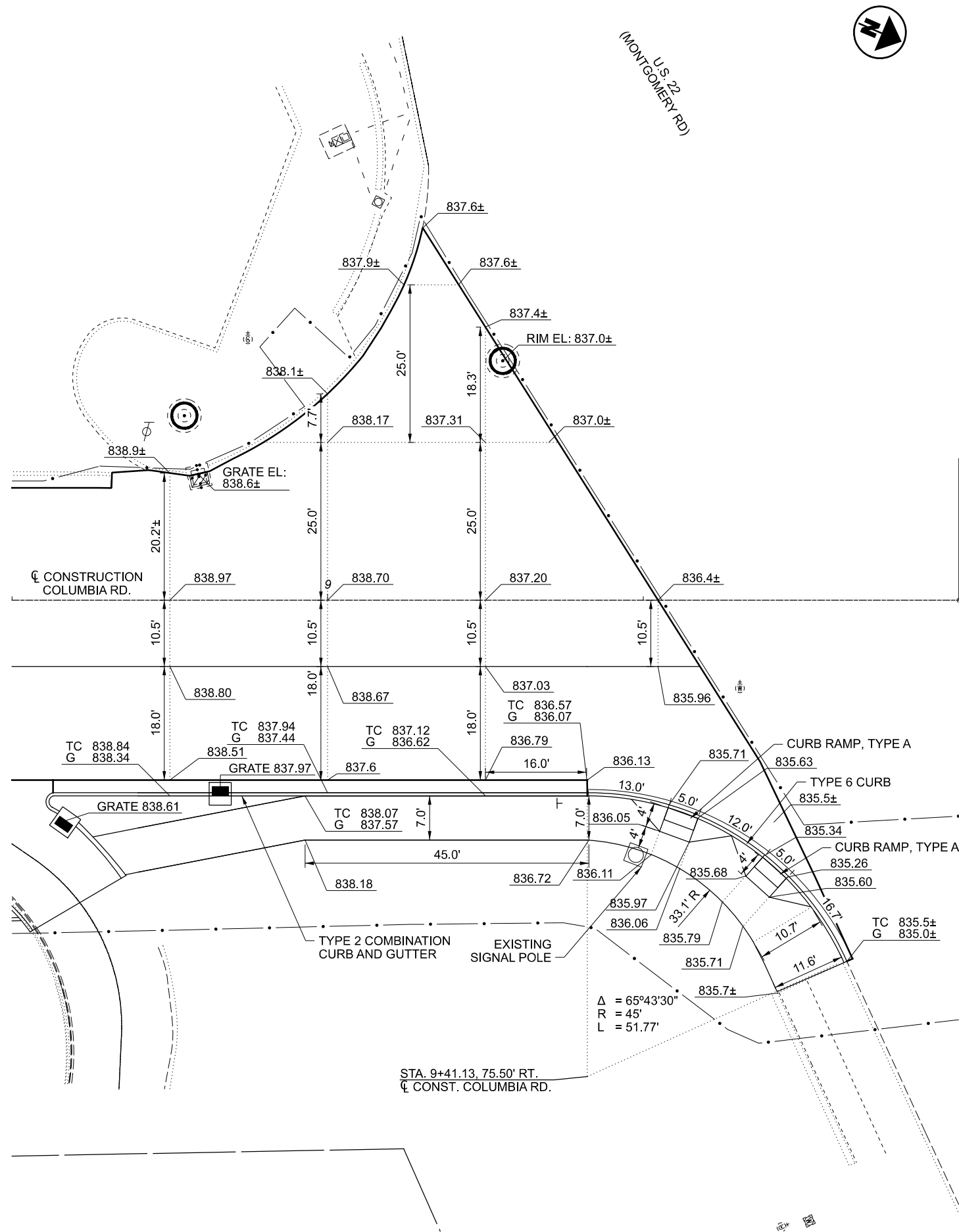

INTERSECTION DETAIL
COLUMBIA ROAD & MONTGOMERY ROAD (US-22/SR-3)

| | |
|--------------------|-------|
| DESIGN AGENCY | |
| CARPENTER MARTY | |
| DESIGNER | |
| BTP | |
| REVIEWER | |
| BAA 06/28/21 | |
| PROJECT ID | |
| COLUMBIA RD | |
| SHEET | TOTAL |
| 15 | 24 |

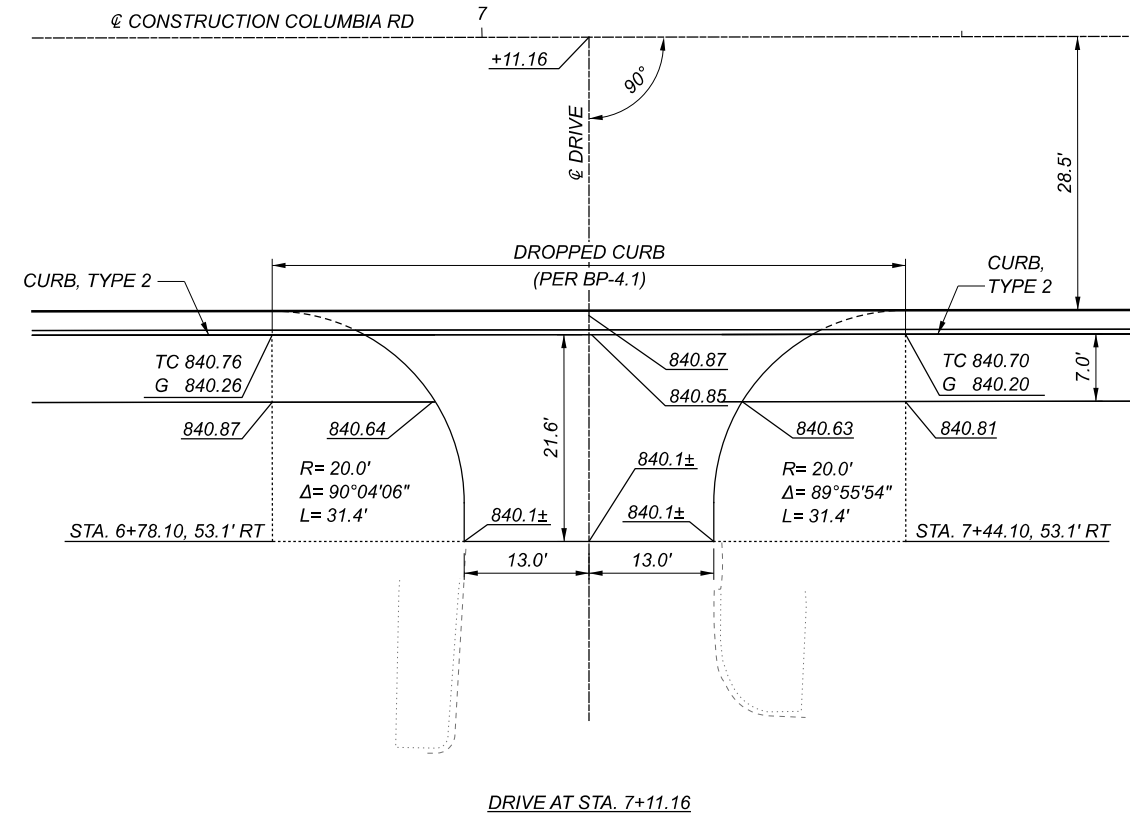

DRIVE AT STA. 7+11.16

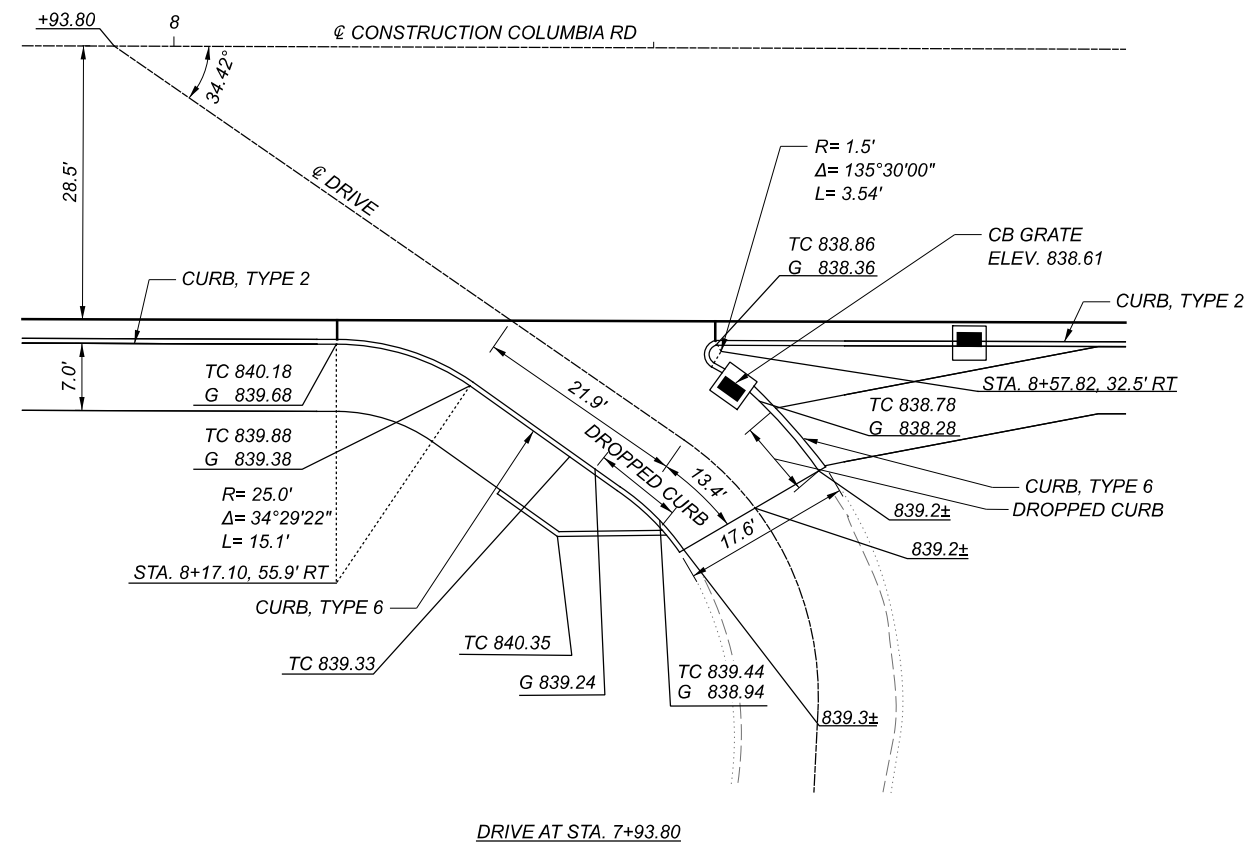

DRIVE AT STA. 7+93.80

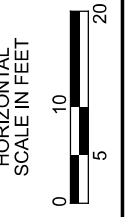

DRIVEWAY DETAILS
COLUMBIA ROAD

DESIGN AGENCY



DESIGNER

BTP

REVIEWER

BAA 06-28-21

PROJECT ID

COLUMBIA RD

SHEET TOTAL

16 24

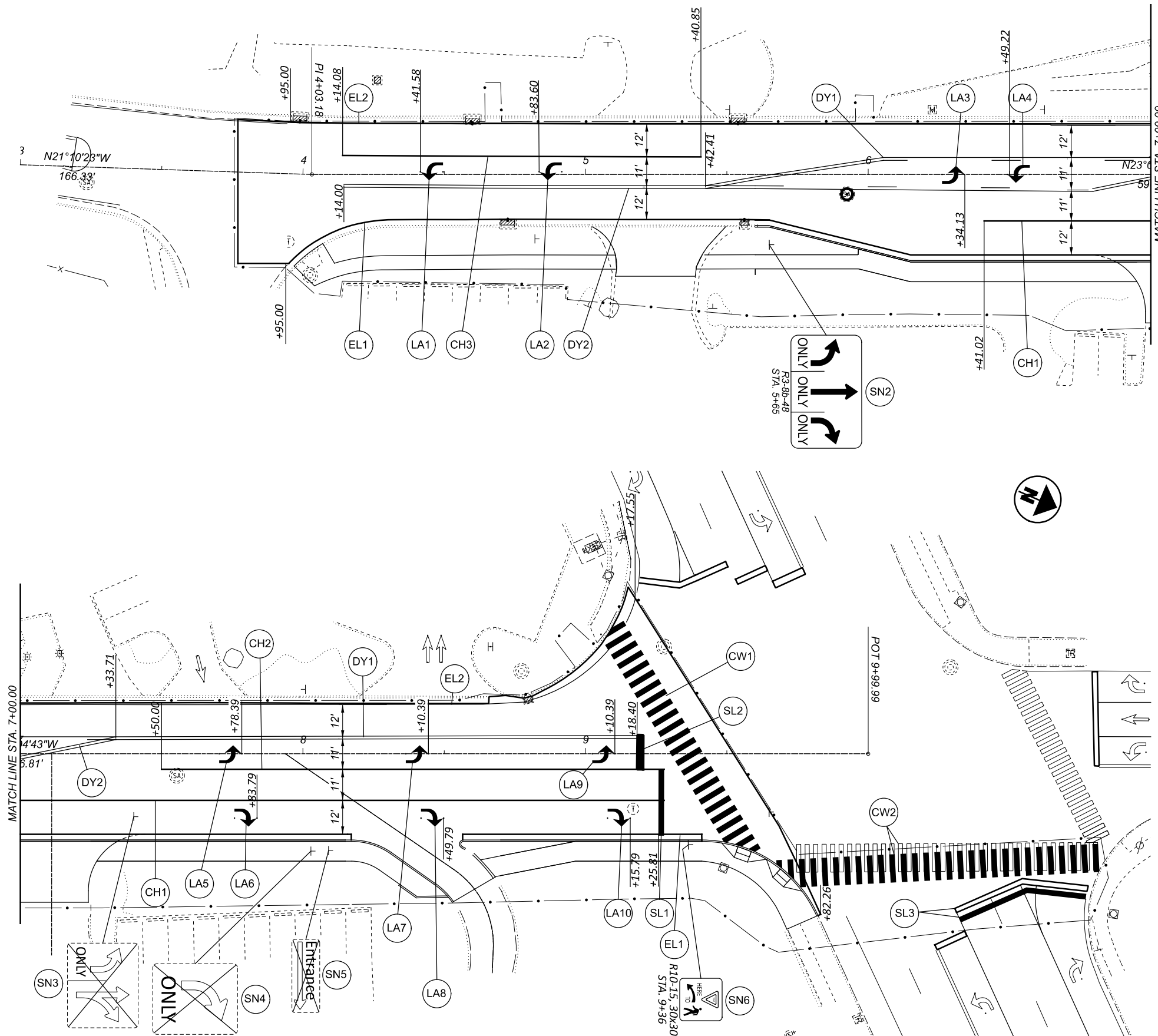

PAVEMENT MARKING LEGEND

- EL# ITEM 644 - EDGE LINE, 4", WHITE
- LA# ITEM 644 - LANE ARROW
- CH# ITEM 644 - CHANNELIZING LINE, 8"
- DY# ITEM 644 - DOUBLE YELLOW (SOLID)
- SL# ITEM 644 - STOP LINE
- CW# ITEM 644 - CROSSWALK LINE, SEE ODOT STD. DWG. TC-74.10

PAVEMENT MARKING PLAN
 COLUMBIA ROAD & MONTGOMERY ROAD (US-22/SR-3)



- NOTES:
 1. FOR SIGNAL PLANS, SEE SHEETS 18 - 20.
 2. ALL EXISTING PAVEMENT MARKINGS TO BE REMOVED AND REPLACED BEGINNING AT STA. 3+95 THROUGH THE INTERSECTION AS SHOWN.

| | |
|---------------|-----------------|
| DESIGN AGENCY | CARPENTER MARTY |
| DESIGNER | BTP |
| REVIEWER | BAA 06/28/21 |
| PROJECT ID | COLUMBIA RD |
| SHEET | TOTAL |
| 17 | 24 |

WORK INSPECTION

THE CONTRACTOR SHALL PROVIDE THE PROJECT ENGINEER AND DISTRICT TRAFFIC ENGINEER WITH 72-HOUR NOTICE OF ANY SIGNAL WORK TO BE PERFORMED AT THE INTERSECTION SITE(S) SO THAT INSPECTION SERVICES CAN BE SUPPLIED.

GUARANTEE

THE CONTRACTOR SHALL GUARANTEE THAT THE TRAFFIC CONTROL SYSTEM INSTALLED AS PART OF THIS CONTRACT SHALL OPERATE SATISFACTORILY FOR A PERIOD OF 90 DAYS FOLLOWING COMPLETION OF THE 10-DAY PERFORMANCE TEST. IN THE EVENT OF UNSATISFACTORY OPERATION, THE CONTRACTOR SHALL CORRECT FAULTY INSTALLATIONS, MAKE REPAIRS AND REPLACE DEFECTIVE PARTS WITH NEW PARTS OF EQUAL OR BETTER QUALITY.

EQUIPMENT, MATERIAL AND LABOR COSTS INCURRED IN CORRECTING AN UNSATISFACTORY OPERATION SHALL BE BORNE BY THE CONTRACTOR.

THE GUARANTEE SHALL COVER THE FOLLOWING ITEMS OF THE TRAFFIC CONTROL SYSTEM: VEHICLE DETECTION EQUIPMENT AND LED LAMP UNITS.

CUSTOMARY MANUFACTURER'S GUARANTEES FOR THE FOREGOING ITEMS SHALL BE TURNED OVER TO THE STATE OR THE MAINTAINING AGENCY FOLLOWING ACCEPTANCE OF THE EQUIPMENT.

THE COST OF GUARANTEEING THE TRAFFIC CONTROL SYSTEM WILL BE INCIDENTAL TO AND INCLUDED IN THE CONTRACT UNIT PRICE OF THE VARIOUS ITEMS MAKING UP THE SYSTEM.

DETECTION MAINTENANCE

IF VEHICLE DETECTION BECOMES UNEXPECTEDLY DISABLED, REQUIRES MODIFICATION, OR IS SCHEDULED TO BE TEMPORARILY REMOVED DURING THE CONSTRUCTION PROJECT, THE CONTRACTOR SHALL IMMEDIATELY NOTIFY THE PROJECT ENGINEER AND DISTRICT TRAFFIC ENGINEER.

IF THE LOSS OF VEHICLE DETECTION IS KNOWN PRIOR TO THE START OF CONSTRUCTION, IT SHALL BE DISCUSSED AT THE PRECONSTRUCTION MEETING. AT SUCH TIME, THE DISTRICT TRAFFIC ENGINEER SHALL ADVISE THE PROJECT ENGINEER AND CONTRACTOR ON THE APPROPRIATE ACTION TO RECTIFY ANY LOSS OF VEHICLE DETECTION. THIS MAY INCLUDE PLACING THE TRAFFIC SIGNAL ON MINIMUM OR MAXIMUM RECALL, MODIFYING THE MINIMUM GREEN TIMES, AND REMOVING THE MALFUNCTIONING DETECTION FROM SERVICE. WHERE NON-INTRUSIVE DETECTION (I.E. VIDEO, RADAR) ALREADY EXISTS, THE CONTRACTOR SHALL INSURE THAT DETECTION IS OPERATING AND MAINTAINED BY RECONFIGURING THE DETECTION UNITS ACCORDINGLY DURING ALL CONSTRUCTION PHASES. THIS IS TO AVOID THE SIGNAL FROM MAXING OUT THE EFFECTED SIGNAL PHASE AND CREATING UNNECESSARY DELAYS.

LOCATIONS WHERE NON-INTRUSIVE DETECTION IS PROPOSED AND THE EXISTING VEHICLE DETECTION IS TO BE ABANDON, THE NON-INTRUSIVE VEHICLE DETECTION SHALL BE INSTALLED, CONFIGURED AND MADE FULLY FUNCTIONAL PRIOR TO THE EXISTING DETECTION BEING DISABLED. THE CONTRACTOR SHALL CONTINUE TO MAINTAIN AND MODIFY THE DETECTION UNTIL FINAL ACCEPTANCE OF THE TRAFFIC SIGNAL. THIS IS TO ENSURE VEHICLE DETECTION REMAINS FULLY FUNCTIONAL THROUGHOUT CONSTRUCTION.

ITEM 809. STOP-LINE RADAR DETECTION, AS PER PLAN

THIS ITEM OF WORK SHALL CONSIST OF FURNISHING AND INSTALLING A WAVETRONIX SMARTSENSOR MATRIX DETECTION UNIT. THE DETECTION UNIT SHALL INCLUDE THE FOLLOWING:

1. POWER SHALL BE PROVIDED FROM THE TRAFFIC CABINET.
2. ALL REQUIRED INPUTS CARDS SHALL BE INCLUDED IN THE TRAFFIC CABINET AND SHALL BE COMPATIBLE WITH CALTRANS, NEMA TS1 AND NEMA TS2 DETECTOR RACKS. THE CARDS SHALL PROVIDE TRUE PRESENCE DETECTOR CALLS OR CONTACT CLOSURE TO THE TRAFFIC CONTROLLER.
3. THE UNIT SHALL BE MOUNTED DIRECTLY TO A POLE OR MAST ARM, AS RECOMMENDED BY THE MANUFACTURER. CABLE(S) SHALL BE PROVIDED AS REQUIRED AND RECOMMENDED BY THE MANUFACTURER.
4. SURGE PROTECTION DEVICES, AS RECOMMENDED BY THE MANUFACTURER SHALL BE INCLUDED BOTH AT THE POLE WHERE THE UNIT IS LOCATED TO PROTECT THE UNIT AND IN THE TRAFFIC CABINET TO PROTECT THE CABINET ELECTRONICS.
5. THE MANUFACTURER'S REPRESENTATIVE SHALL BE ON SITE DURING INSTALLATION AND TESTING AND SHALL PROVIDE ONSITE TRAINING ON THE SETUP, OPERATION AND MAINTENANCE OF THE UNIT.
6. A SERIAL TO ETHERNET COMMUNICATIONS MODULE AND ETHERNET CABLE (MINIMUM 7 FEET).
7. THE POWER SUPPLY AND COMMUNICATION MODULES SHALL BE SECURED TO A SINGLE PANEL THAT CAN BE MOUNTED INTERIOR TO THE TRAFFIC CABINET. THE PANEL SHALL INCLUDE MODULAR-PLUG STYLE CONNECTIONS FOR UP TO FOUR (4) SENSOR CABLES. ADDITIONAL SENSORS MAY BE HARD-WIRED TO THE COMMUNICATION MODULES, AS NECESSARY.
8. THE CONTRACTOR SHALL INSTALL THE RADAR DETECTION PRIOR TO MILLING/DISABLING EXISTING LOOPS.
9. THE INSTALLATION SHALL INCLUDE ALL CONTROLLER PROGRAMMING FOR COMPLETE INSTALLATION, WHICH INCLUDES MODIFICATIONS FOR REMOVAL OF EXISTING DETECTION.

PAYMENT FOR ITEM 809 STOP-LINE RADAR DETECTION, AS PER PLAN SHALL BE MADE AT THE CONTRACT UNIT PRICE FOR EACH UNIT, COMPLETE AND IN PLACE INCLUDING ALL REQUIRED CABINET HARDWARE, MOUNTING BRACKETS, CABLES, CONDUIT AND CONNECTIONS TESTED AND ACCEPTED.

ITEM 632. SIGNALIZATION, MISC.: UNLASH AND RELASH MESSENGER WIRE

THE CONTRACTOR SHALL REMOVE EXISTING MESSENGER WIRE LASHING RODS AND REINSTALL THEM AS NECESSARY FOR THE INSTALLATION OF ANY NEW CABLES ON THE EXISTING INTERSECTION SIGNAL SPANS. THE CABLES SHALL ENTER THE EXISTING STRAIN POLE THROUGH THE POLE CABLE ENTRANCE FITTING AND USE THE EXISTING CONDUIT SYSTEM TO GET TO THE CONTROLLER CABINET. THE NEW CABLES SHALL BE SUPPORTED BY A NEW CABLE SUPPORT ASSEMBLY AT THE TOP OF THE STRAIN POLE.

THE NEW SIGNAL CABLES SHALL BE BID BY SEPARATE BID ITEMS.

PAYMENT FOR ITEM 632 "SIGNALIZATION MISC.: UNLASH AND RELASH MESSENGER WIRE" SHALL BE MADE AT THE CONTRACT UNIT PRICE PER FOOT AND SHALL INCLUDE ALL LABOR, MATERIALS, CABLE SUPPORT ASSEMBLIES AND EQUIPMENT TO INSTALL NEW CABLES ON EXISTING SIGNAL SPAN WIRE INSTALLATIONS.

ITEM 632. REMOVAL OF TRAFFIC SIGNAL INSTALLATION, AS PER PLAN

TRAFFIC SIGNAL INSTALLATIONS, INCLUDING SIGNAL HEADS, CABLE, TRAFFIC PULL BOXES, ETC. SHALL BE REMOVED IN ACCORDANCE WITH C&MS 632.26 AND AS INDICATED ON THE PLANS.

SEE SHEET 19 FOR THE TRAFFIC SIGNAL REMOVAL CHART.

TRAFFIC SIGNALS SUBSUMMARY

| ITEM | QUANTITY | UNIT | ITEM DESCRIPTION | SEE SHEET NUMBER |
|------|----------|------|--|------------------|
| 630 | 1 | EACH | SIGN HANGER ASSEMBLY, SPAN WIRE | |
| 630 | 7.5 | SF | SIGN, FLAT SHEET | |
| 632 | 1 | EACH | VEHICULAR SIGNAL HEAD, (LED), 5-SECTION, 12" LENS, 1-WAY, POLYCARBONATE, BLACK | |
| 632 | 1 | EACH | COVERING OF VEHICULAR SIGNAL HEAD | |
| 632 | 291 | FT | SIGNAL CABLE, 7 CONDUCTOR, NO. 14 AWG | |
| 632 | 1 | EACH | REMOVAL OF TRAFFIC SIGNAL INSTALLATION, AS PER PLAN | 18 |
| 632 | 310 | FT | SIGNALIZATION, MISC.: UNLASH AND RELASH MESSENGER WIRE | 18 |
| 809 | 2 | EACH | STOP-LINE RADAR DETECTION, AS PER PLAN | 18 |

TRAFFIC CONTROL SUBSUMMARY

| REF NO. | SHEET NO. | STATION TO STATION | | 621 | 630 | 630 | 630 | 644 | 644 | 644 | 644 | 644 | 644 | 644 | |
|-----------------------------------|-----------|--------------------|----|----------|------------------|------------------------------------|---|---------------|-------------|-----------------------|---------------------|------------|-----------|-----------------------------|-----|
| | | | | RPM | SIGN. FLAT SHEET | GROUND MOUNTED SUPPORT, NO. 3 POST | REMOVAL OF GROUND MOUNTED SIGN AND DISPOSAL | EDGE LINE, 4" | CENTER LINE | CHANNELIZING LINE, 8" | CROSSWALK LINE, 24" | LANE ARROW | STOP LINE | REMOVAL OF PAVEMENT MARKING | |
| | | | | EACH | SF | FT | EACH | MILE | MILE | FT | FT | EACH | FT | FT | |
| EL1 | 17 | 3+95.00 | TO | 9+82.26 | | | | 0.11 | | | | | | | |
| EL2 | 17 | 3+95.00 | TO | 9+17.55 | | | | 0.10 | | | | | | | |
| DY1 | 17 | 5+42.41 | TO | 9+18.40 | 6 | | | | 0.07 | | | | | | |
| DY2 | 17 | 4+14.00 | TO | 7+33.71 | 6 | | | | 0.06 | | | | | | |
| CH1 | 17 | 6+41.02 | TO | 9+27.81 | 8 | | | | | 287 | | | | | |
| CH2 | 17 | 7+50.00 | TO | 9+27.81 | 6 | | | | | 178 | | | | | |
| CH3 | 17 | 4+14.08 | TO | 5+40.85 | 4 | | | | | 127 | | | | | |
| CW1 | 17 | 9+06.80 | TO | 9+65.41 | | | | | | | 397 | | | | |
| CW2 | 17 | 9+65.29 | TO | 10+81.53 | | | | | | | 218 | | | 310 | |
| LA1 | 17 | 4+41.58 | | | | | | | | | | | 1 | | |
| LA2 | 17 | 4+83.60 | | | | | | | | | | | 1 | | |
| LA3 | 17 | 6+34.13 | | | | | | | | | | | 1 | | |
| LA4 | 17 | 6+49.22 | | | | | | | | | | | 1 | | |
| LA5 | 17 | 7+78.39 | | | | | | | | | | | 1 | | |
| LA6 | 17 | 7+83.79 | | | | | | | | | | | 1 | | |
| LA7 | 17 | 8+44.39 | | | | | | | | | | | 1 | | |
| LA8 | 17 | 8+49.79 | | | | | | | | | | | 1 | | |
| LA9 | 17 | 9+10.39 | | | | | | | | | | | 1 | | |
| LA10 | 17 | 9+15.79 | | | | | | | | | | | 1 | | |
| SL1 | 17 | 9+18.40 | TO | 9+20.40 | | | | | | | | | | 11.5 | |
| SL2 | 17 | 9+25.81 | TO | 9+27.81 | | | | | | | | | | 23.5 | |
| SL3 | 17 | 10+32.05 | TO | 10+77.22 | | | | | | | | | | 47.5 | 50 |
| SN2 | 17 | 5+65.00 | | | | | | | | | | | | | |
| SN3 | 17 | 7+40.00 | | | 10.0 | 15.5 | | | | | | | | | |
| SN4 | 17 | 8+03.00 | | | | | 1 | | | | | | | | |
| SN5 | 17 | 8+06.00 | | | | | 1 | | | | | | | | |
| SN6 | 17 | 9+36.00 | | | | | 1 | | | | | | | | |
| TOTALS CARRIED TO GENERAL SUMMARY | | | | | 30 | 19.0 | 30.0 | 4 | 0.21 | 0.13 | 592 | 615 | 10 | 83 | 360 |

DESIGN AGENCY

 DESIGNER
NRB
 REVIEWER
 NAU 06/28/21
 PROJECT ID
 COLUMBIA RD
 SHEET TOTAL
 18 | 24

NOTES:
 1. ALL STATIONING AND OFFSETS BASED OFF @ CONSTRUCTION COLUMBIA ROAD
 2. PROPOSED FIVE-SECTION SIGNAL HEAD SHALL BE ALIGNED WITH THE NORTHBOUND CHANNELIZING LINE SEPARATING THE THROUGH LANE AND RIGHT TURN LANE.

ITEM 632 - REMOVAL OF TRAFFIC SIGNAL INSTALLATION, AS PER PLAN

| QUANTITY | REMOVED ITEM DESCRIPTION | DISPOSED OF BY CONTRACTOR | STORED FOR PICK UP |
|----------|--------------------------|---------------------------|--------------------|
| LUMP | SIGNAL CABLE | X | |
| 1 | VEHICULAR SIGNAL HEADS | X | |
| 2 | TRAFFIC PULL BOXES | X | |
| | | | |

VEHICULAR SIGNAL HEADS
 12" LED LENSES W/ BACKPLATES

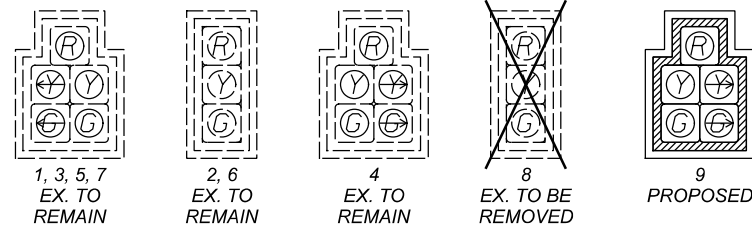

EXISTING SIGNS

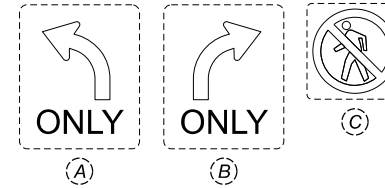

PROPOSED SIGNS

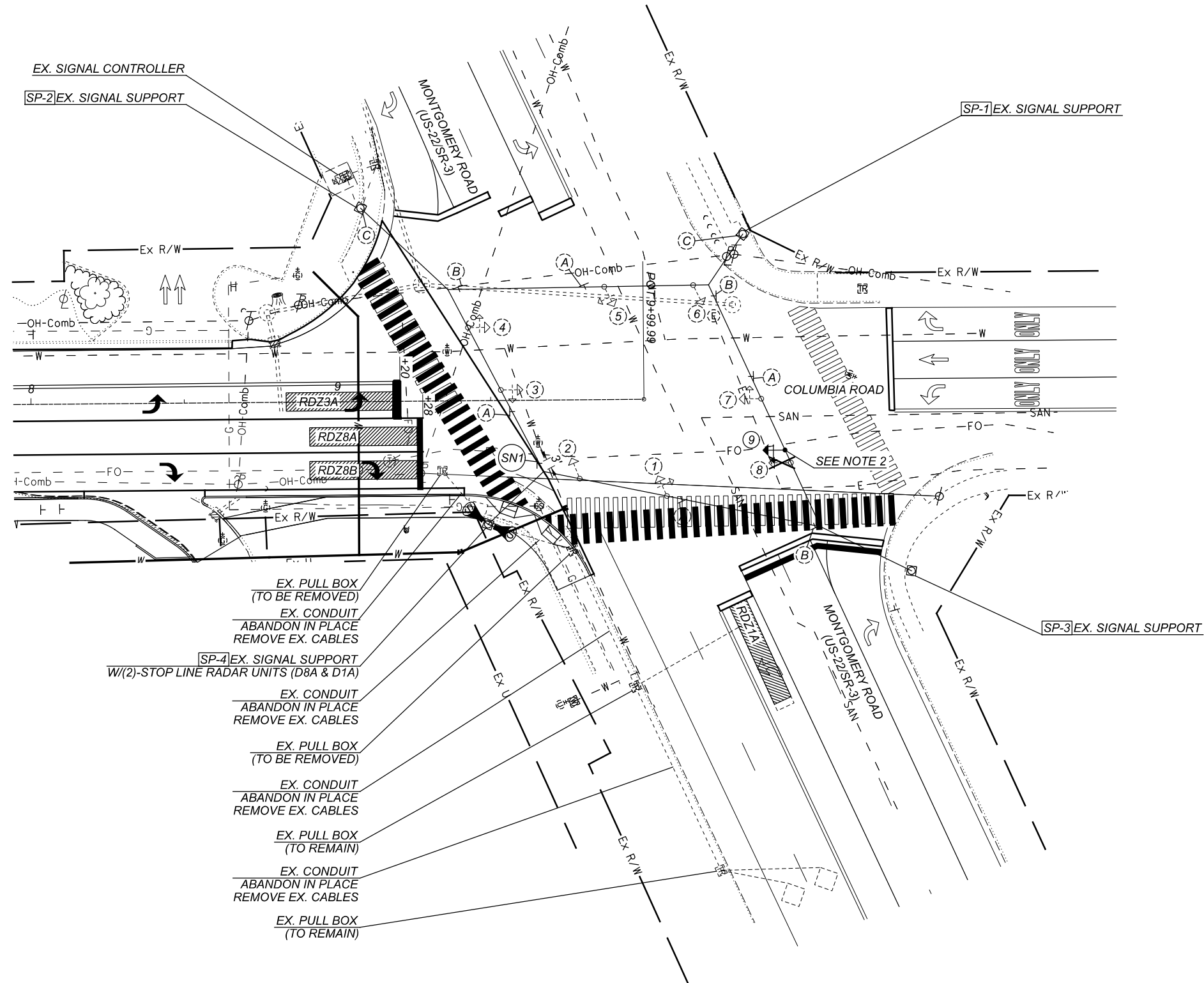
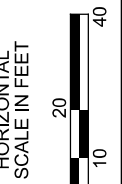
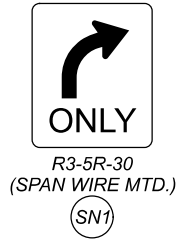

LEGEND

| | EX. | PROP. |
|----------------------------------|-----|-------|
| TRAFFIC SIGNAL, 3 UNIT HEAD, 12" | ←-○ | ←-○ |
| TRAFFIC SIGNAL, 5 UNIT HEAD, 12" | ←-○ | ←-○ |
| SIGNAL SUPPORT POLE | □ | □ |
| CONTROLLER CABINET AND WORK PAD | □ | □ |
| TRAFFIC PULL BOX | □ | □ |

SIGNAL TIMING CHART

| INTERSECTION: COLUMBIA ROAD & MONTGOMERY ROAD (US-22/SR-3) MAINTAINING AGENCY: OHIO DEPARTMENT OF TRANSPORTATION | | | | | | | | |
|---|-------------------------|-----------------|------|-------------|------|------------|------|-----|
| START UP | | DUAL ENTRY: EX. | | PHASES: EX. | | | | |
| START IN: | EX. | REST IN RED: | | RING 1 EX. | | RING 2 EX. | | |
| TIME FOR FLASH, ALL RED: | EX. | OVERLAP | | A | B | C | D | |
| FIRST PHASE(S): | EX. | PHASES | | Ø1 | Ø5 | - | - | |
| COLOR DISPLAYED: | EX. | | | | | | | |
| INTERVAL OR FEATURE | CONTROLLER MOVEMENT NO. | | | | | | | |
| INTERSECTION MOVEMENT (PHASE) | 1 | 2 | 3 | 4 | 5 | 6 | 7 | 8 |
| DIRECTION | WBLT | EB | NBLT | SB | EBLT | WB | SBLT | NB |
| MINIMUM GREEN (INITIAL) (SEC.) | EX. | EX. | EX. | EX. | EX. | EX. | EX. | EX. |
| ADDED INITIAL *(SEC./ACTUATION) | EX. | EX. | EX. | EX. | EX. | EX. | EX. | EX. |
| MAXIMUM INITIAL (SEC.) | EX. | EX. | EX. | EX. | EX. | EX. | EX. | EX. |
| PASSAGE TIME (PRESET GAP) (SEC.) | EX. | EX. | EX. | EX. | EX. | EX. | EX. | EX. |
| TIME BEFORE REDUCTION *(SEC.) | EX. | EX. | EX. | EX. | EX. | EX. | EX. | EX. |
| MINIMUM GAP *(SEC.) | EX. | EX. | EX. | EX. | EX. | EX. | EX. | EX. |
| TIME TO REDUCE *(SEC.) | EX. | EX. | EX. | EX. | EX. | EX. | EX. | EX. |
| MAXIMUM GREEN I (SEC.) | EX. | EX. | EX. | EX. | EX. | EX. | EX. | EX. |
| MAXIMUM GREEN II (SEC.) | EX. | EX. | EX. | EX. | EX. | EX. | EX. | EX. |
| YELLOW CHANGE (SEC.) | EX. | EX. | EX. | EX. | EX. | EX. | EX. | EX. |
| ALL RED CLEARANCE (SEC.) | EX. | EX. | EX. | EX. | EX. | EX. | EX. | EX. |
| DELAYED GREEN (LPI) # (SEC.) | EX. | EX. | EX. | EX. | EX. | EX. | EX. | EX. |
| WALK (SEC.) | EX. | 7 | EX. | 14 | EX. | 7 | EX. | EX. |
| FLASHING YELLOW ARROW DELAY # | EX. | EX. | EX. | EX. | EX. | EX. | EX. | EX. |
| PEDESTRIAN CLEARANCE (SEC.) | EX. | 21 | EX. | 29 | EX. | 17 | EX. | EX. |
| RECALL | MAXIMUM (ON/OFF) | EX. | EX. | EX. | EX. | EX. | EX. | EX. |
| | MINIMUM (ON/OFF) | EX. | EX. | EX. | EX. | EX. | EX. | EX. |
| | PEDESTRIAN (ON/OFF) | EX. | EX. | EX. | EX. | EX. | EX. | EX. |
| MEMORY (ON/OFF) | EX. | EX. | EX. | EX. | EX. | EX. | EX. | EX. |

PHASING DIAGRAM

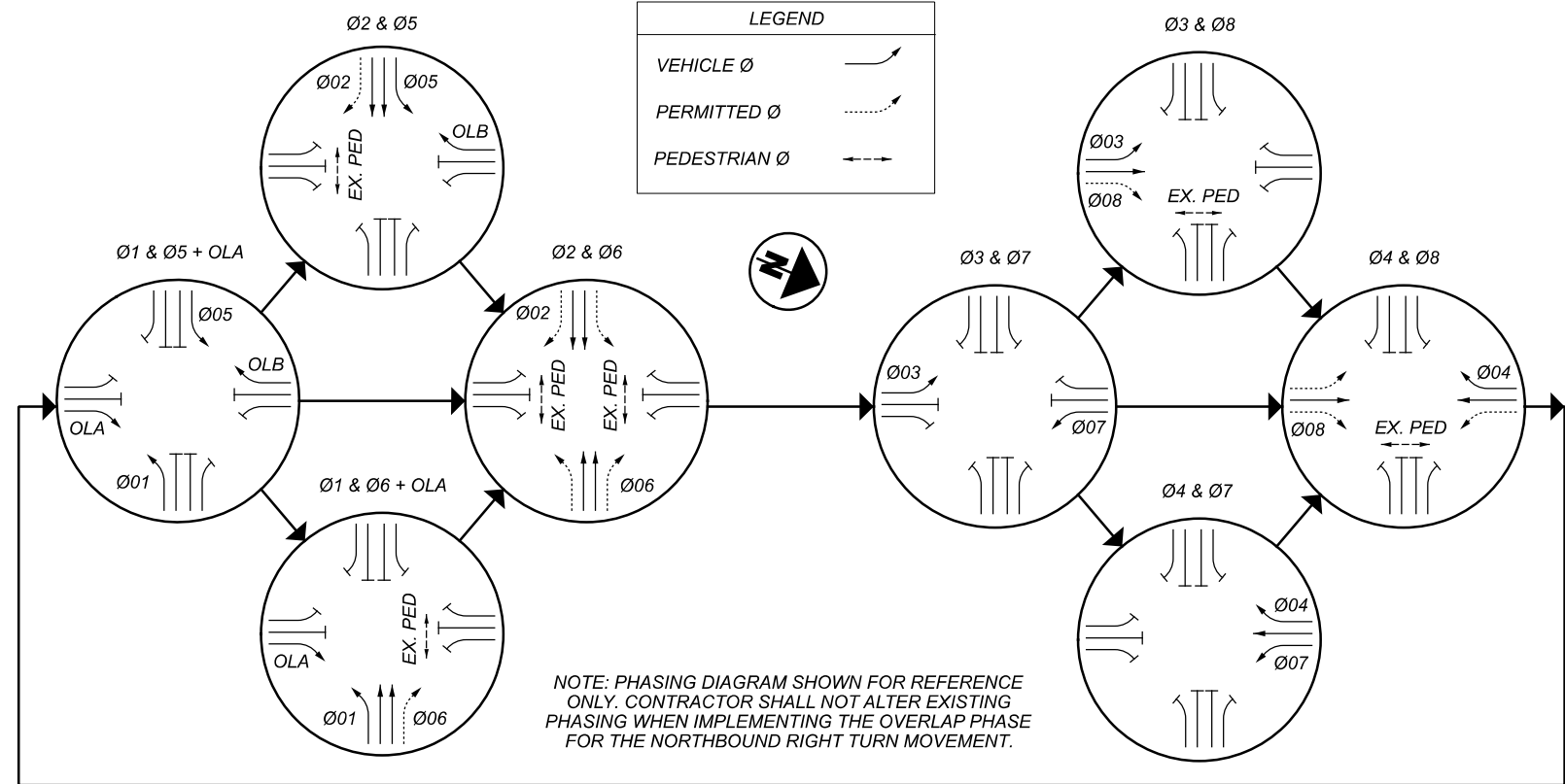

RADAR DETECTION CHART

| DETECTION ZONE | MOVEMENT | WIDTH | DELAY PROGRAMMED IN CONTROLLER (SEC.) | EXTENSION PROGRAMMED IN CONTROLLER (SEC.) | DETECTOR NUMBER | PURPOSE | DETECTION ZONE LENGTH |
|----------------|----------|-------|---------------------------------------|---|-----------------|-----------|-----------------------|
| RDZ1A | WBLT | 6' | - | - | D1A | STOP LINE | 35' |
| RDZ3A | NBLT | 6' | - | - | D8A | STOP LINE | 35' |
| RDZ8A | NB | 6' | - | - | D8A | STOP LINE | 35' |
| RDZ8B | NBRT | 6' | 12 | - | D8A | STOP LINE | 35' |

FIELD WIRING HOOK-UP CHART

| SIGNAL HEAD | INDICATION | FIELD TERMINAL | FLASH |
|-------------|------------|----------------|-------|
| 9 NBRT | R | Ø8 R | R |
| | Y | Ø8 Y | |
| | G | Ø8 G | |
| | -Y> | Ø1 Y | |
| | -G> | Ø1 R | |

LS = LOAD SWITCH OLA = LS 13

WIRING DIAGRAM (NOT TO SCALE)

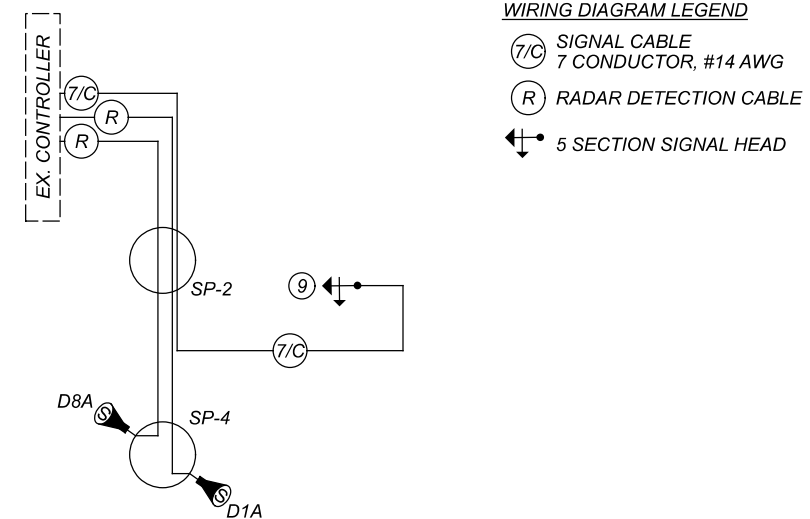

WATER WORK NOTES

1. ALL WATER MAINS SHALL HAVE A MINIMUM COVER OF 4'-6"
 A. ALL WATER SERVICE LATERALS SHALL HAVE MINIMUM COVER OF 42"
2. ALL WATER MAINS SHALL BE DUCTILE IRON CONFORMING WITH AWWA SPEC. C-151 CLASS 52 IN SIZES 4"-16" AND PSI CLASS 350 FOR 20" AND ABOVE.
3. COMPACT FITTINGS ARE PERMITTED.
4. ALL WATER VALVES MUST OPEN LEFT. ALL VALVE BOX LIDS MUST BE CAST/STAMPED "WCWD" IN 1 1/2" LETTERS AND BE NEENAH-NF-19130002 OR EQUAL. ALL VALVE EXTENSIONS TO HAVE SET SCREWS.
5. A CONCRETE SLAB MUST BE PROVIDED AT FINAL GRADE AROUND ALL MAIN VALVE BOXES. THE SLABS MUST BE EIGHTEEN INCHES (18") SQUARE/CIRCLE AND NINE INCHES (9") THICK. PREFABRICATED CONCRETE RINGS ARE ACCEPTABLE
6. WATER AND SEWER LINES SHALL HAVE A MINIMUM OF TEN FEET (10') HORIZONTAL SEPARATION AND/OR TWO FEET (2') VERTICAL SEPARATION.
7. NO GATE VALVE, METER PIT, BLOW OFF OR CORPORATION STOP SHALL BE LOCATED UNDER OF WITHIN THREE FEET (3') OF DRIVEWAYS, ROADWAYS OR SIDEWALK.
8. NO DRIVEWAY SHALL BE INSTALLED WITHIN FIVE FEET (5') OF A FIRE HYDRANT.
9. A MINIMUM OF THREE FEET (3') IS REQUIRED BETWEEN CORPORATION STOPS. NO TAP SHALL BE MADE WITHIN THREE (3') OF A BELL.
10. THE LOCATION OF WATER SERVICE LATERALS MUST BE STAMPED IN THE CURB AT THE TIME THE CURB IS PLACED TO PERMANENTLY INDICATE THE LOCATION OF SAID LATERALS.
11. THE LOCATION OF ALL WATER SERVICE LATERALS BENDS, TEE, ETC. MUST BE PROVIDED ON THE AS-BUILT PLANS. ALL OF THESE APPURTENANCES SHOULD BE SURVEYED IN STATE PLANE COORDINATES AND ELECTRONICALLY DELIVERED TO THE OWNER.
12. CONTRACTOR SHALL SUBMIT AS-BUILT PLANS OF SANITARY AND WATER LATERALS TO THE OWNER.
13. ALL WATER MAINS CROSSING UNDER STORM DRAINS SHALL BE BACKFILLED WITH GRANULAR MATERIAL, ODOT ITEM 310.02, BETWEEN MAINS AND DRAINS.
14. EACH SERVICE LATERAL MUST BE A CONTINUOUS PIECE OF PIPE FROM THE CORP STOP TO THE METER. COUPLINGS SHALL NOT BE ALLOWED. TYPE K COPPER SHALL BE USED FOR 3/4" AND 1" SERVICES. POLYETHYLENE 200 PSI (COPPER TUBE SIZE) MAY BE USED FOR 1 1/2" AND 2" SERVICES. TRACER WIRE MUST BE USED WITH POLY AND SDR 21.

WATER WORK NOTES (CONTINUED)

15. SERVICE LINES 1" AND LARGER MUST BE EITHER TYPE K COPPER, PLY 200 PSI OR SDR 21. TRACER WIRE MUST BE TAPED EVENLY EVERY 3' ON POLY AND SDR 21 FROM THE METER PIT INTO THE STRUCTURE BEING SERVED (A 3' LEAD IS REQUIRED INTO THE PIT).
16. 1 1/2" AND 2" SERVICE LINES FROM THE CORP STOP TO THE METER PIT MUST BE TYPE K COPPER OR POLYETHYLENE 200 PSI. POLY MUST HAVE A TRACER WIRE.
17. SWAB PIPE WITH 50 PPM CHLORINE SOLUTION BE INSTALLATION.
18. ALL NEW WATER MAINS SHALL BE PRESSURE TESTED FOR 2 HOURS AT 200 PSI, WHICHEVER IS GREATER. ALLOWABLE LEAKAGE SHALL BE PER TABLE 6A OF AWWA C-600.
19. DEDUCT METERS SHALL NOT BE ALLOWED.
20. NO IRRIGATION CONNECTIONS SHALL BE ALLOWED IN THE METER PIT.
21. BACK FLOW PREVENTER THAT COMPLIES WITH A.S.S.E. 1013 IS TO BE INSTALLED AHEAD OF ANY SPRINKLER BUT NOT IN THE METER PIT.
22. ALL MATERIALS USED SHALL BE DOMESTIC, MADE IN THE UNITED STATES OF AMERICA.
23. ALL WATER LINES TO BE ABANDONED SHALL BE PLUGGED PER WARREN COUNTY WATER AND SERWER STANDARDS AND REGULATIONS

| SHEET NO. | STATION TO STATION | 202 | 638 | 638 | 638 | 638 | 638 | 638 | 638 |
|-----------|--------------------|---------------------|--|----------------------------|--------------------------|----------------------------------|---------------|--|-----|
| | | METER VAULT REMOVED | 8" WATER MAIN DUCTILE IRON PIPE ANSI CLASS 52, PUSH-ON JOINTS AND FITTINGS | 3/4" COPPER SERVICE BRANCH | 1" COPPER SERVICE BRANCH | METER, SETTING, STOP AND CHAMBER | 8" GATE VALVE | 12" X 8" TAPPING SLEEVE, VALVE AND VALVE BOX | 638 |
| | | EACH | FT | FT | FT | EACH | EACH | EACH | FT |
| 22-23 | 3+83.47 TO 9+06.94 | 3 | 628 | 138 | 80 | 3 | 2 | 1 | 520 |

**WATER WORK
GENERAL NOTES**

DESIGN AGENCY

DESIGNER
WCS

REVIEWER
BAA 01-20-22

PROJECT ID
COLUMBIA RD

SHEET TOTAL
21 | 24

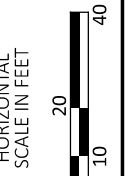
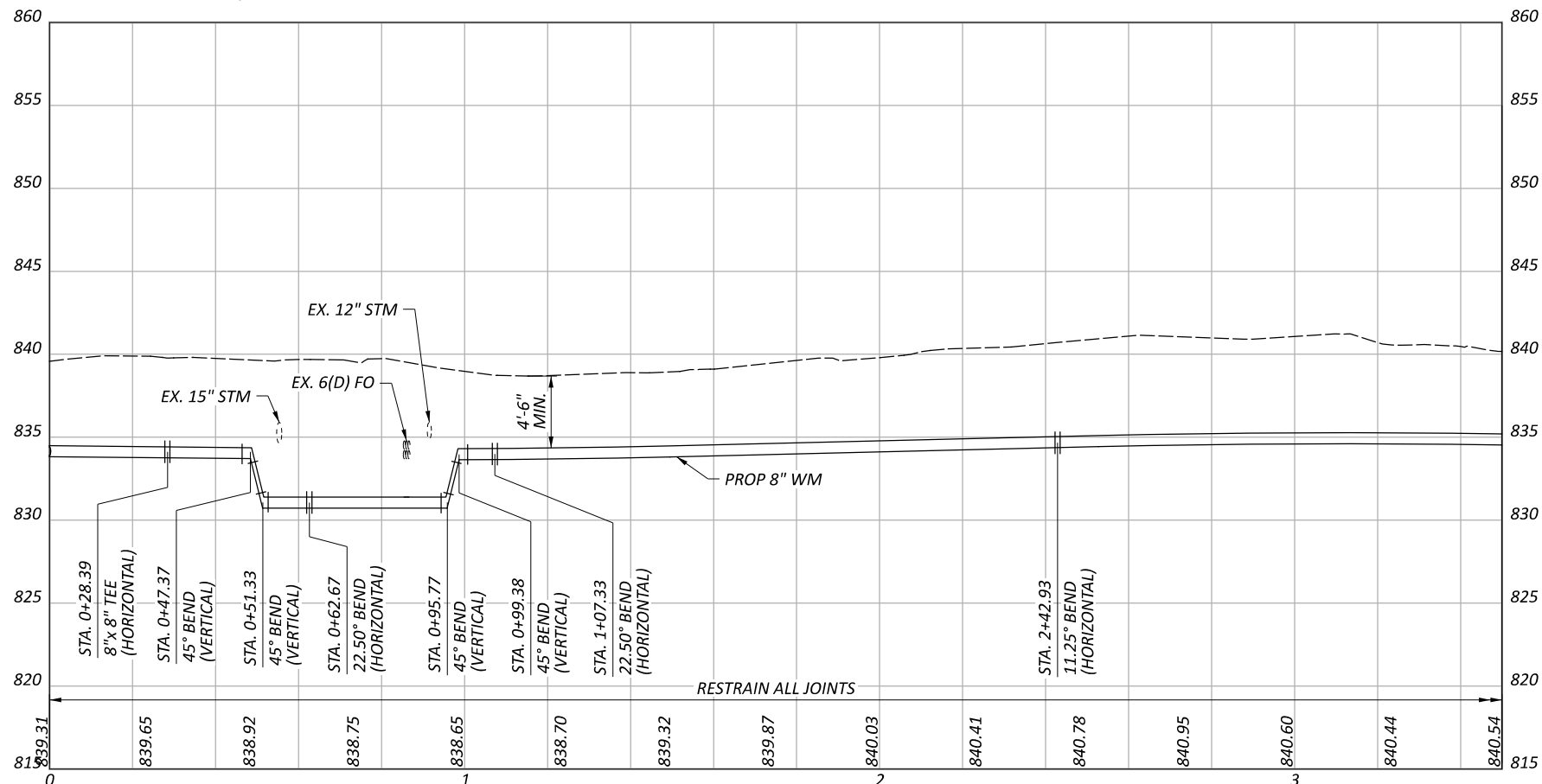
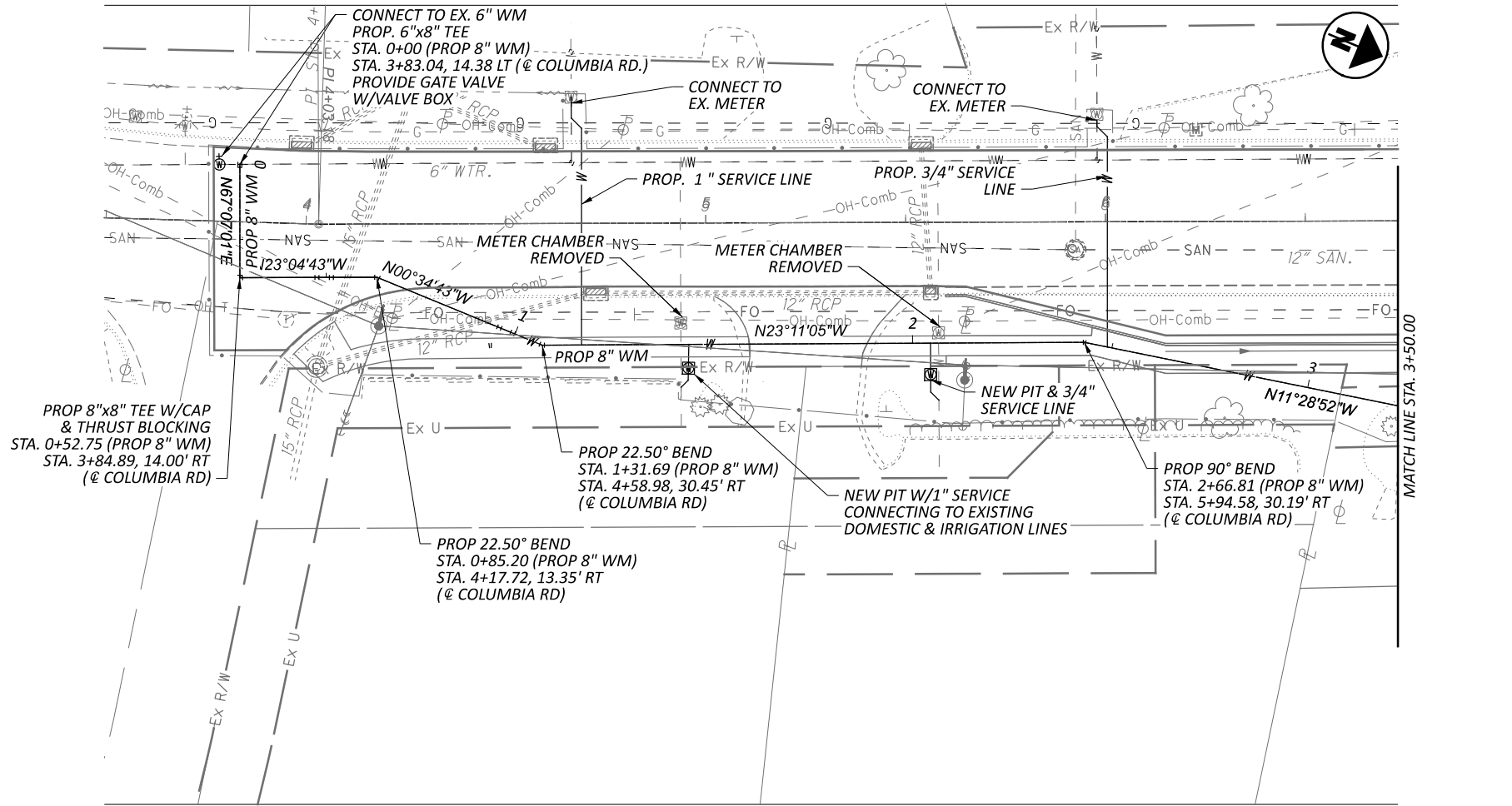

WATER WORK - PLAN AND PROFILE
 STA. 0+00.00 TO STA. 3+50.00

DESIGN AGENCY



DESIGNER

WCS

REVIEWER

BAA 01/04/22

PROJECT ID

COLUMBIA RD

SHEET TOTAL

22 24

COLUMBIA RD.

MODEL: Columbia - WaterWork02 PAPER SIZE: 17x11 (in.) DATE: 2/24/2022 TIME: 11:09:24 AM USER: backel
 P:\WAR\TR\0002\Columbia Rd\400-Engineering\Utilities\Sheets\Columbia - WaterWork02.dgn

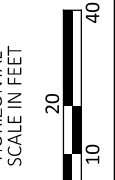
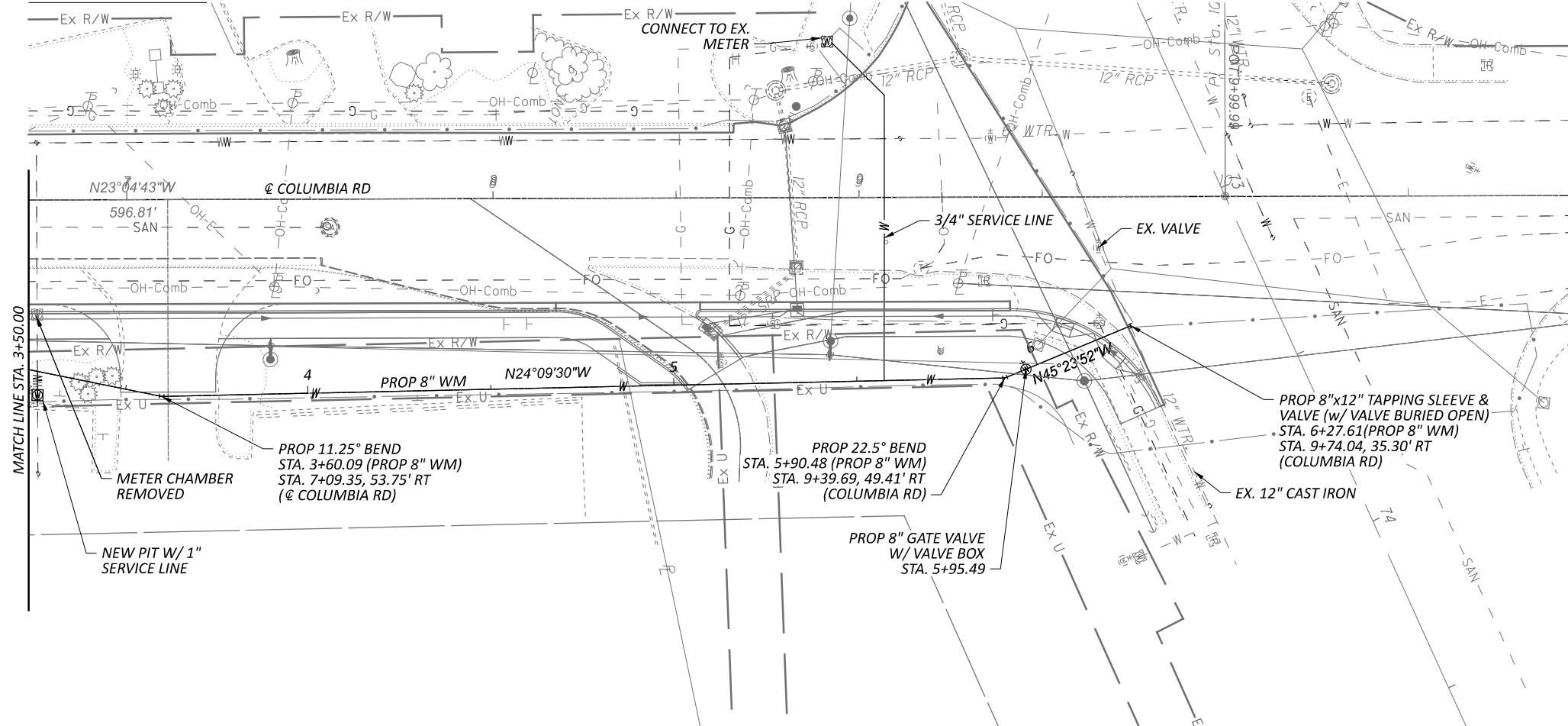
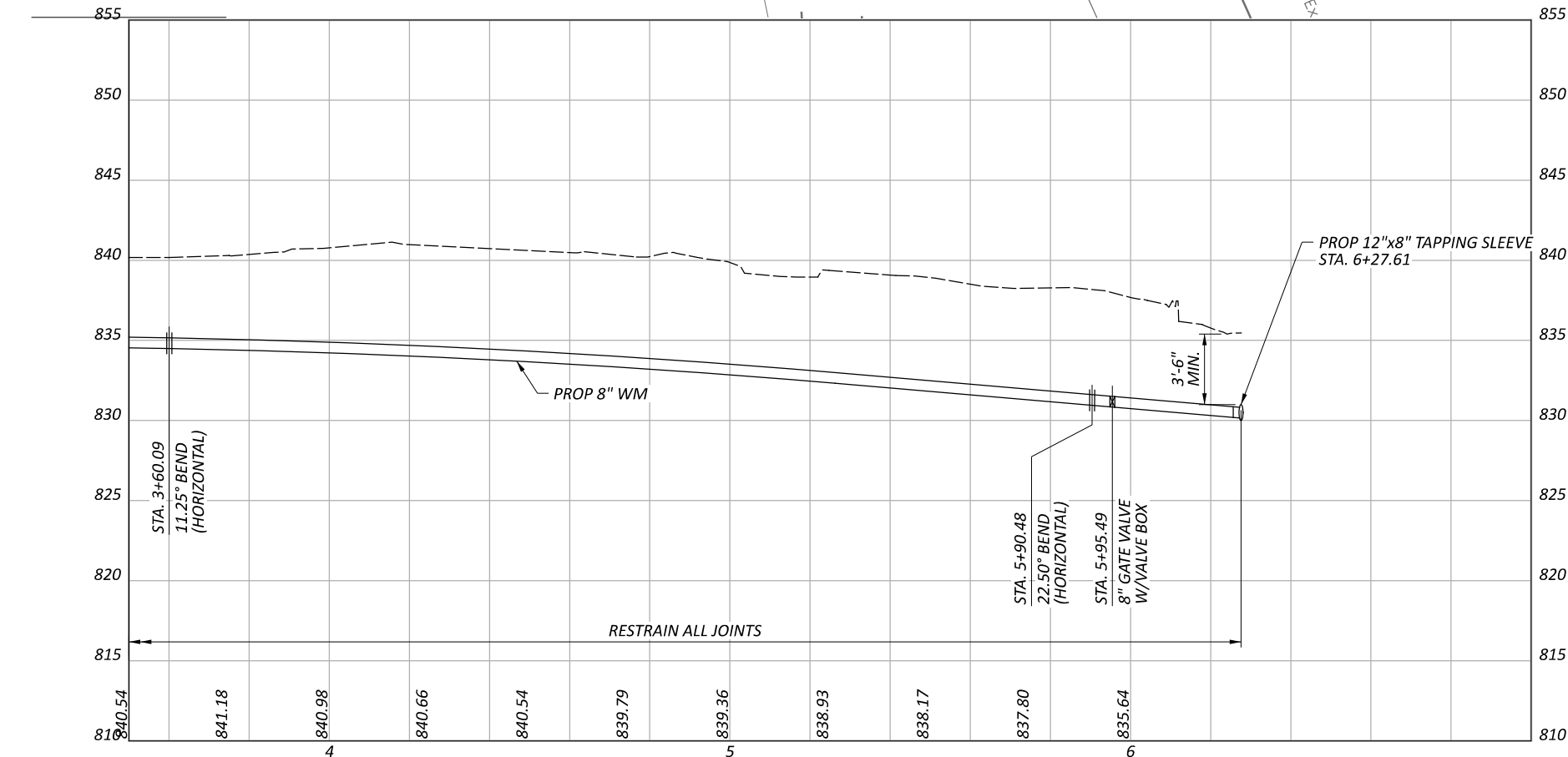

**WATER WORK - PLAN AND PROFILE
 STA. 3+50.00 TO STA. 5+00.00**

DESIGN AGENCY



DESIGNER

WCS

REVIEWER

BAA 01/04/22

PROJECT ID

COLUMBIA RD

SHEET

TOTAL

23 | 24

THRUST BLOCK DETAILS

| | | |
|--------------------------------|---|-------------------------------|
| APPROVED/REVISED JUNE, 2012 | WARREN COUNTY STANDARD DETAILS DEPARTMENT OF WATER & SEWER | STANDARD NUMBER W-3 |
|--------------------------------|---|-------------------------------|

ANCHORS & BUTTRESSES FOR VERTICAL BENDS

| | | |
|---------------------------------|---|--------------------------------|
| APPROVED/REVISED MARCH, 2018 | WARREN COUNTY STANDARD DETAILS DEPARTMENT OF WATER & SEWER | STANDARD NUMBER W-17 |
|---------------------------------|---|--------------------------------|

METER BOX DETAIL FOR 3/4" AND 1" METERS

| | | |
|---------------------------------|---|---------------------------------|
| APPROVED/REVISED MARCH, 2018 | WARREN COUNTY STANDARD DETAILS DEPARTMENT OF WATER & SEWER | STANDARD NUMBER W-10A |
|---------------------------------|---|---------------------------------|

REQUIRED RESTRAINED JOINTS FOR BENDS

MINIMUM 54' OF RESTRAINED JOINT PIPE (RJP) IS REQUIRED BEFORE AND AFTER ALL BENDS. REFER TO TABLE BELOW.

RESTRAINT OPTIONS:
 MECHANICAL JOINT W/ MEGALUGS ~ ALL SIZES OF PIPE
 MJ FIELD LOCKS ~ < 24" PIPE

| d | 4" | 6" | 8" | 10" | 12" | 16" | 20" | 24" |
|---|-----|-----|-----|-----|-----|-----|------|------|
| l | 54' | 54' | 54' | 54' | 66' | 98' | 125' | 145' |

| | | |
|---------------------------------|---|--------------------------------|
| APPROVED/REVISED MARCH, 2018 | WARREN COUNTY STANDARD DETAILS DEPARTMENT OF WATER & SEWER | STANDARD NUMBER W-18 |
|---------------------------------|---|--------------------------------|

REQUIRED RESTRAINED JOINTS - DEAD END VALVES, PLUGS, CAPS & TEES

MINIMUM 54' OF RESTRAINED JOINT PIPE (RJP) IS REQUIRED BEFORE AND AFTER ALL BENDS. REFER TO TABLE BELOW.

| d | 4" | 6" | 8" | 10" | 12" | 16" | 20" | 24" |
|---|-----|-----|-----|-----|-----|-----|------|------|
| l | 54' | 54' | 54' | 54' | 66' | 98' | 125' | 145' |

| | | |
|---------------------------------|---|--------------------------------|
| APPROVED/REVISED MARCH, 2018 | WARREN COUNTY STANDARD DETAILS DEPARTMENT OF WATER & SEWER | STANDARD NUMBER W-19 |
|---------------------------------|---|--------------------------------|

ROAD PAVEMENT CUT AND RESTORATION AT ROADWAY CROSSING

ALL DIMENSIONS ARE MINIMUM - ACTUAL TO BE PER COUNTY ENGINEER OR ODOT INSTRUCTIONS & PERMIT.

TRAFFIC MUST BE MAINTAINED AT ALL TIMES; LIGHTS, SIGNS, BARRICADES AND IF NECESSARY, FLAGMAN AND WATCHMEN TO BE ON JOB FOR PROTECTION OF THE PUBLIC. STREET PLATES MUST CONFORM TO COUNTY ENGINEER OR ODOT REQUIREMENTS.

FLASHFILL OR CONTROLLED DENSITY FILL TO A MINIMUM DISTANCE OF 5 FEET BEYOND THE EDGE OF PAVEMENT. TRENCH BACKFILL AND PAVEMENT RESTORATION MUST CONFORM TO THE APPLICABLE WARREN COUNTY ENGINEER OR ODOT SPECIFICATIONS.

EXISTING PAVEMENT EDGES SHALL BE NEATLY AND SQUARELY TRIMMED AND/OR MILLED. PAVEMENT MUST MATCH EXISTING ROAD THICKNESS OR AS SPECIFIED BY COUNTY ENGINEER OR ODOT.

| | | |
|---------------------------------|---|--------------------------------|
| APPROVED/REVISED MARCH, 2018 | WARREN COUNTY STANDARD DETAILS DEPARTMENT OF WATER & SEWER | STANDARD NUMBER W-20 |
|---------------------------------|---|--------------------------------|

WARREN COUNTY ENGINEER'S OFFICE COLUMBIA ROAD TURN LANE

PROJECT DESCRIPTION

THIS PROJECT CONSISTS OF WIDENING COLUMBIA ROAD WITH THE ADDITION OF A RIGHT TURN LANE AND SIDEWALK BETWEEN US 22/SR 3 AND KINGSLEY COURT. THIS PROJECT INCLUDES REPLACEMENT AND RELOCATION OF THE EXISTING 6" WATER MAIN WITH A NEW 8" WATER MAIN.

EARTH DISTURBED AREAS

PROJECT EARTH DISTURBED AREA: 0.47 ACRES
 ESTIMATED CONTRACTOR EARTH DISTURBED AREA: 0.13 ACRES
 NOTICE OF INTENT EARTH DISTURBED AREA: N/A (NOI NOT REQUIRED)

2019 SPECIFICATIONS

THE STANDARD SPECIFICATIONS OF THE STATE OF OHIO, DEPARTMENT OF TRANSPORTATION, INCLUDING SUPPLEMENTAL SPECIFICATIONS LISTED IN THE PLANS AND CHANGES LISTED IN THE PROPOSAL SHALL GOVERN THIS IMPROVEMENT.

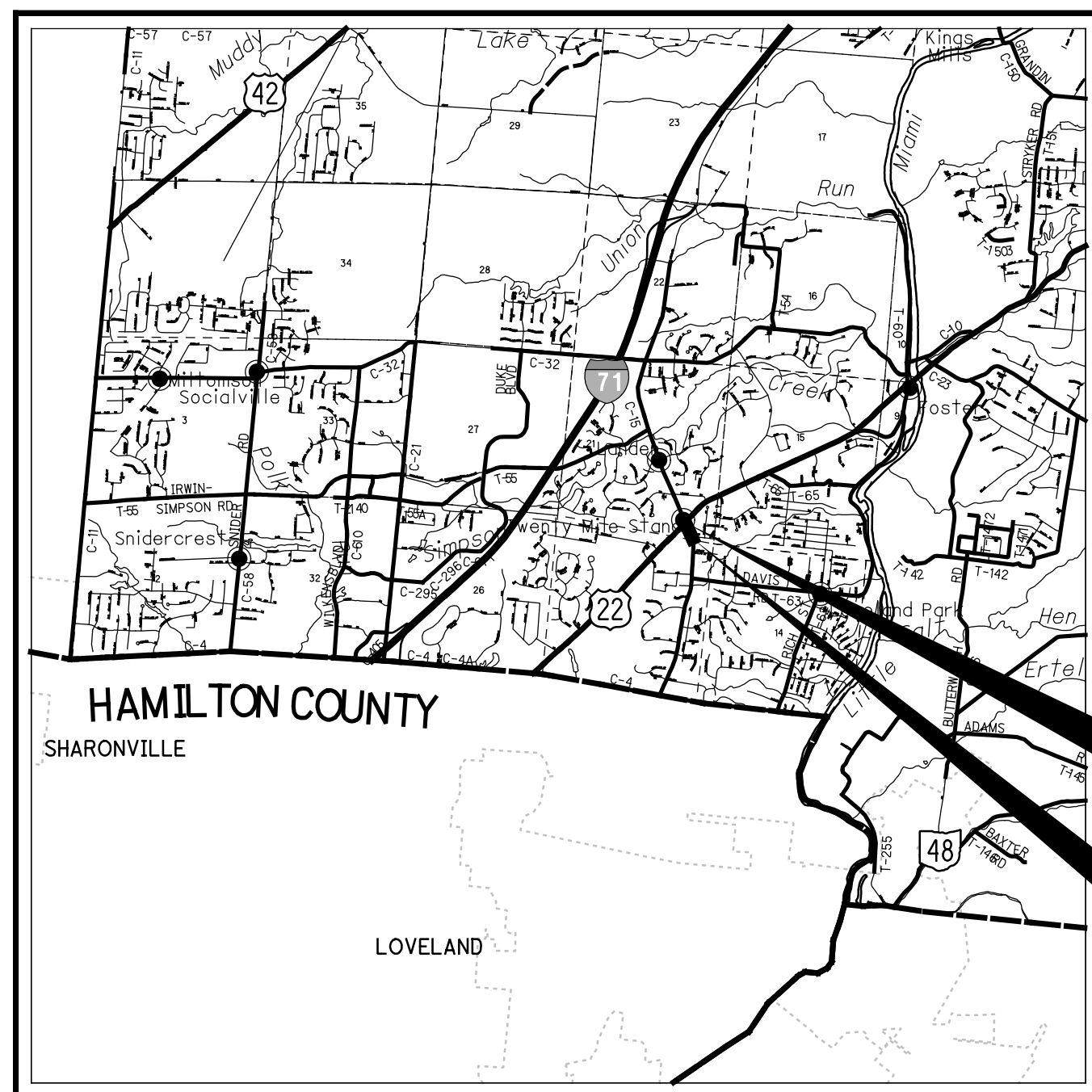

LOCATION MAP

LATITUDE: 39°18'22" LONGITUDE: -84°16'47"

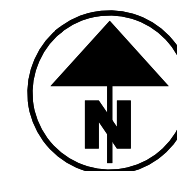

| | | |
|-------------------------|-------|-------|
| PORTION TO BE IMPROVED | ————— | ————— |
| INTERSTATE HIGHWAY | ————— | ————— |
| FEDERAL ROUTES | ————— | ————— |
| STATE ROUTES | ————— | ————— |
| COUNTY & TOWNSHIP ROADS | ————— | ————— |
| OTHER ROADS | ————— | ————— |

INDEX OF SHEETS:

| | |
|------------------------|-------|
| TITLE SHEET | 1 |
| TYPICAL SECTIONS | 2 |
| GENERAL NOTES | 3 |
| MAINTENANCE OF TRAFFIC | 4-5 |
| GENERAL SUMMARY | 6-7 |
| ROADWAY SUBSUMMARY | 8 |
| PLAN AND PROFILE | 9 |
| CROSS SECTIONS | 10-14 |
| INTERSECTION DETAILS | 15 |
| DRIVEWAY DETAILS | 16 |
| TRAFFIC CONTROL PLAN | 17 |
| SIGNAL SHEETS | 18-20 |
| WATER WORK | 21-24 |

TITLE SHEET

UNDERGROUND UTILITIES

Contact Two Working Days Before You Dig



OHIO811, 8-1-1, or 1-800-362-2764
 (Non-members must be called directly)

PLAN PREPARED BY:



ENGINEER'S SEAL:



SIGNED: *Bradley A. Ackel*
 DATE: 02/07/2022

| STANDARD CONSTRUCTION DRAWINGS | | | | SUPPLEMENTAL SPECIFICATIONS | |
|--------------------------------|----------|-----------|---------|-----------------------------|-----------|
| CB-3A | 7/16/21 | TC-65.11 | 7/21/17 | 800 | 1/21/2022 |
| MH-3 | 7/16/21 | TC-71.10 | 1/19/18 | 809 | 1/18/2019 |
| DM-1.1 | 7/17/20 | TC-74.10 | 1/21/22 | 909 | 1/21/2022 |
| DM-1.2 | 7/16/21 | TC-82.10 | 1/18/19 | | |
| DM-4.4 | 1/15/16 | TC-85.21 | 7/16/21 | | |
| BP-3.1 | 1/17/20 | TC-85.22 | 1/19/18 | | |
| BP-4.1 | 7/19/13 | | | | |
| BP-5.1 | 1/18/19 | MT-95.31 | 7/19/19 | | |
| BP-7.1 | 7/17/20 | MT-95.50 | 7/21/17 | | |
| | | MT-101.90 | 7/17/20 | | |
| TC-41.20 | 10/18/13 | | | | |
| TC-41.41 | 10/18/13 | HL-30.11 | 1/15/21 | | |
| TC-42.20 | 10/18/13 | | | | |
| TC-52.10 | 10/18/13 | | | | |
| TC-52.20 | 1/15/21 | | | | |
| TC-65.10 | 1/17/14 | | | | |

APPROVED _____
 DATE _____ WARREN COUNTY ENGINEER

DESIGN AGENCY



DESIGNER
 BTP

REVIEWER

BAA 06-28-21

PROJECT ID

COLUMBIA RD

SHEET TOTAL

1 | 24

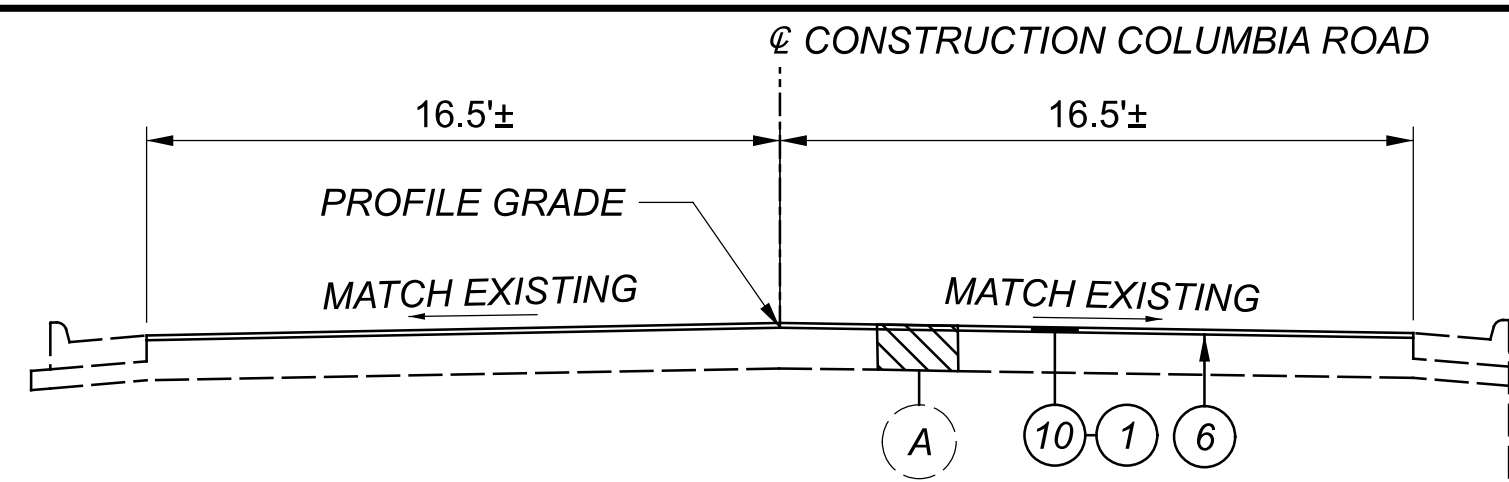

MILL & FILL SECTION - COLUMBIA ROAD

SECTION APPLIES:
 STA. 3+77.00 TO STA. 5+60.00

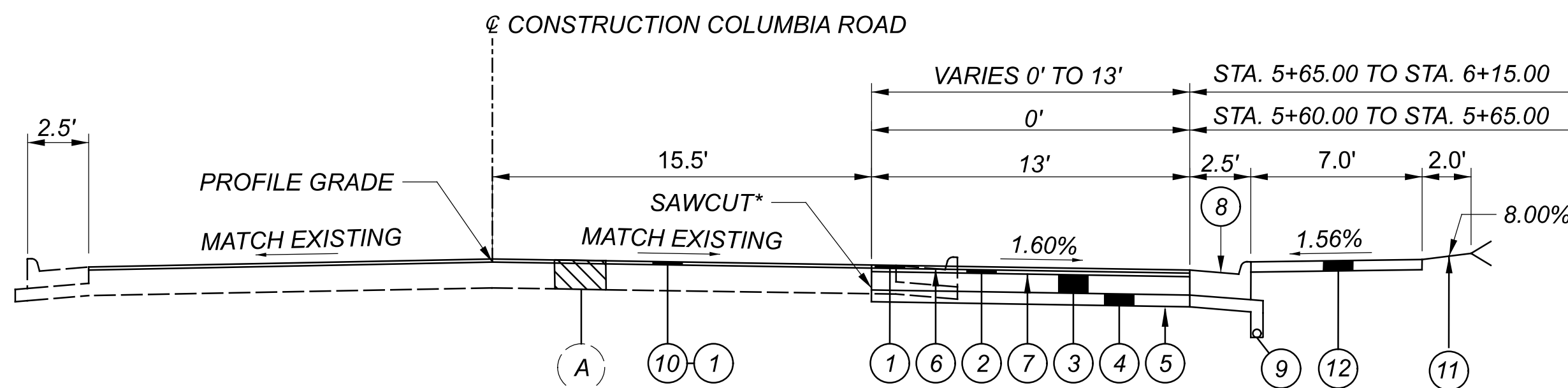

NORMAL SECTION - PROPOSED COLUMBIA ROAD

SECTION APPLIES:
 STA. 5+60.00 TO STA. 7+32.00

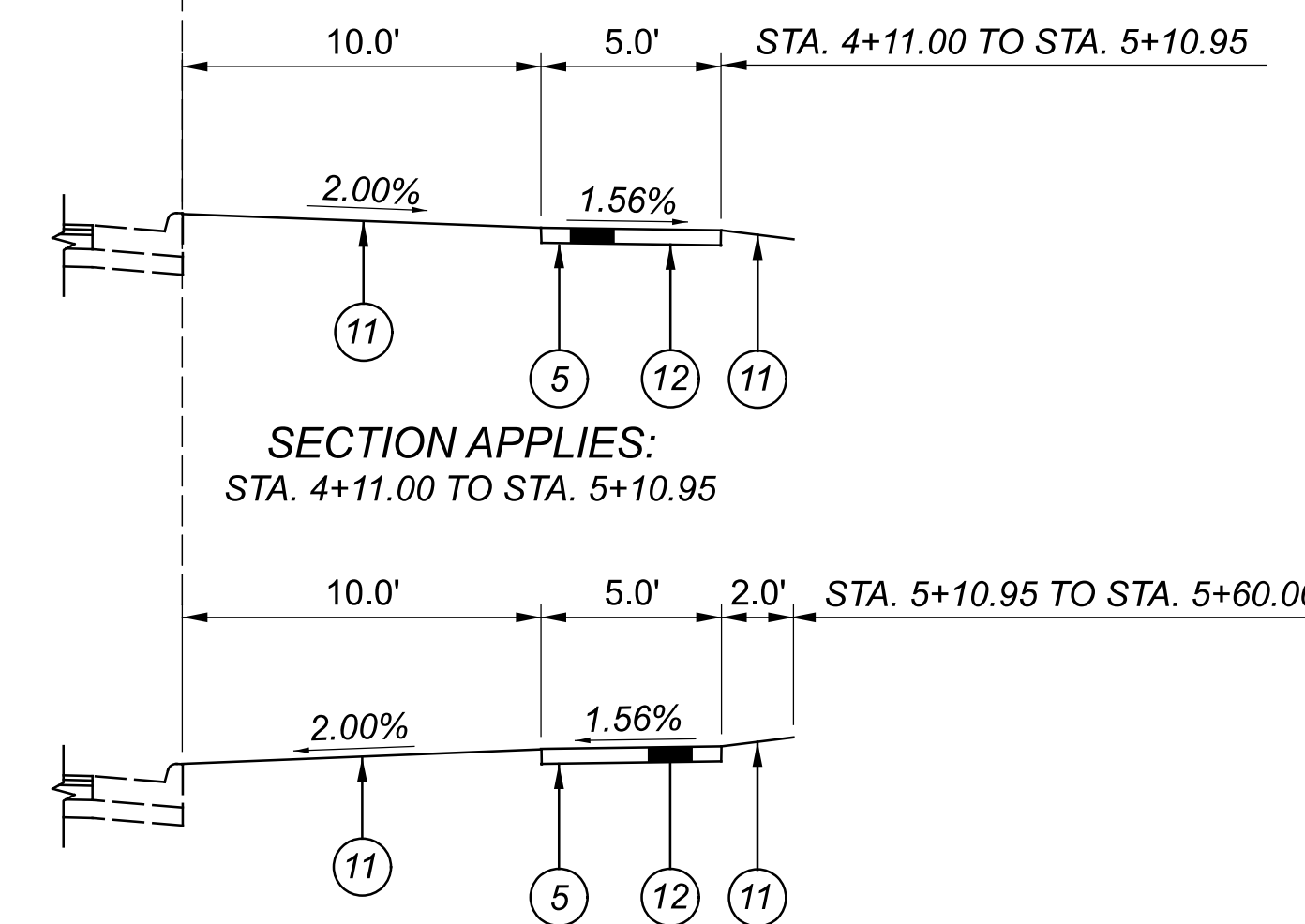

SECTION APPLIES:
 STA. 5+10.95 TO STA. 5+60.00

*NOTE: SAWCUT 1' MIN. FROM EX. CURB OR TO SOLID PAVEMENT

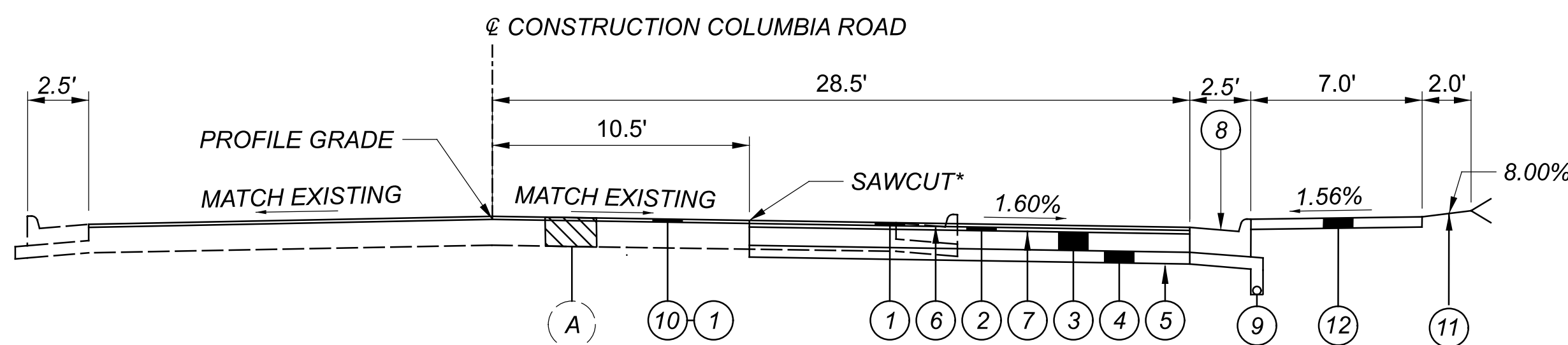

NORMAL SECTION - PROPOSED COLUMBIA ROAD

SECTION APPLIES:
 STA. 7+32.00 TO STA. 9+41.13
 STA. 9+41.13 TO STA. 9+83.17 (SEE INTERSECTION DETAIL)

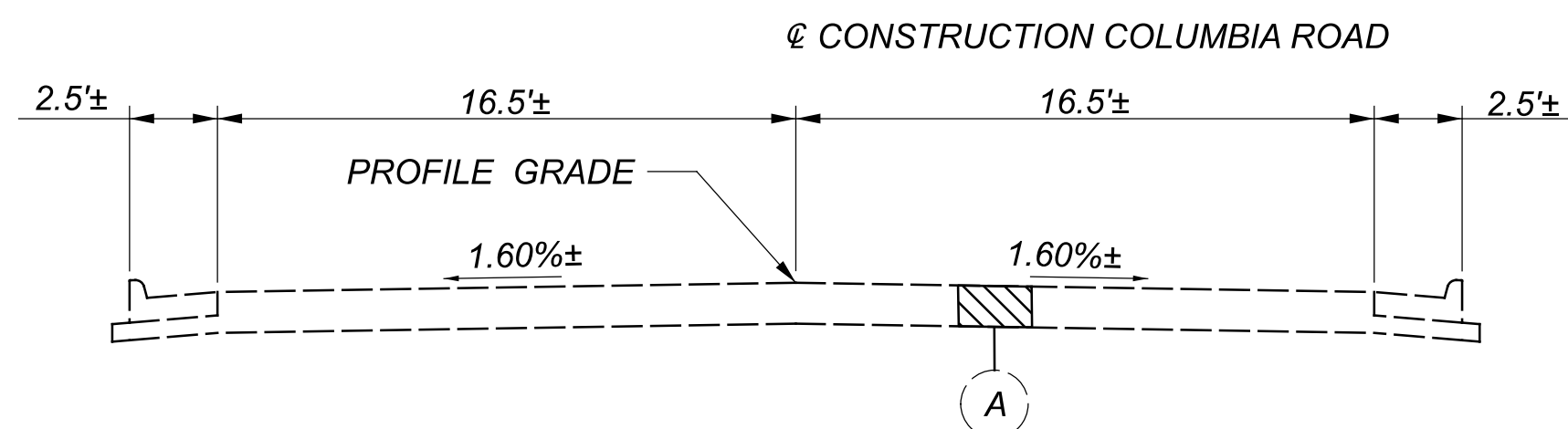

NORMAL SECTION - EXISTING COLUMBIA ROAD

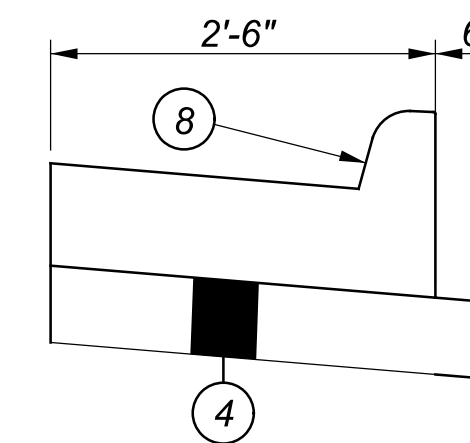

STEP DETAIL

LEGEND

- | | | |
|--|--|--------------------------------------|
| ① ITEM 441 1½" ASPHALT CONCRETE SURFACE COURSE, TYPE 1, (448), PG64-22 | ⑥ ITEM 407 | ⑪ ITEM 659 SEEDING AND MULCHING |
| ② ITEM 441 1¾" ASPHALT CONCRETE INTERMEDIATE COURSE, TYPE 2, (448) | ⑦ ITEM 407 TACK COAT (0.085 GAL/SY) | ⑫ ITEM 608 5" CONCRETE WALK |
| ③ ITEM 302 9" ASPHALT CONCRETE BASE, PG64-22 | ⑧ ITEM 609 COMBINATION CURB AND GUTTER, TYPE 2 | Ⓐ EXISTING ASPHALT CONCRETE PAVEMENT |
| ④ ITEM 304 6" AGGREGATE BASE | ⑨ ITEM 605 4" SHALLOW PIPE UNDERDRAIN | |
| ⑤ ITEM 204 SUBGRADE COMPACTION | ⑩ ITEM 254 PAVEMENT PLANING, ASPHALT CONCRETE (1½" AT PROFILE GRADE) | |

UTILITIES

LISTED BELOW ARE ALL UTILITIES LOCATED WITHIN THE PROJECT CONSTRUCTION LIMITS TOGETHER WITH THEIR RESPECTIVE OWNERS:

| | |
|--|---|
| TIM MEYER DUKE ENERGY ELECTRIC RECORDS 2010 DANA AVE, EF324 CINCINNATI, OH 45207 | KYLE BUCKLEY GREATER CINCINNATI WATER WORKS 4747 SPRING GROVE AVE CINCINNATI, OH 45232 |
|--|---|

| | |
|---|---|
| BRIAN HOLLMANN DUKE ENERGY GAS RECORDS 139 E. FOURTH ST., RM. 460A CINCINNATI, OH 45202 | JOHN STRAUSS CINCINNATI BELL NETWORK OPERATIONS - SPECIALIST OUTSIDE PLANT ENGINEER 221 E. FOURTH ST. (BLDG. 121-900) CINCINNATI, OH 45201 |
|---|---|

| | |
|---|--|
| KENT RIEGER SPECTRUM CONSTRUCTION COORDINATOR 10920 KENWOOD ROAD CINCINNATI, OH 45242 | SARAH EMANS COMNET, INC PLANT GIS & DESIGN OSP MANAGER 13888 COUNTY ROAD 25A WAPAKONETA, OHIO |
|---|--|

THE LOCATION OF THE UNDERGROUND UTILITIES SHOWN ON THE PLANS ARE AS OBTAINED FROM THE OWNERS AS REQUIRED BY SECTION 153.64 O.R.C.

SURVEYING PARAMETERS

PRIMARY PROJECT CONTROL MONUMENTS GOVERN ALL POSITIONING ON ODOT PROJECTS. SEE BELOW FOR A TABLE CONTAINING PROJECT CONTROL INFORMATION.

USE THE FOLLOWING PROJECT CONTROL, VERTICAL POSITIONING, AND HORIZONTAL POSITIONING PARAMETERS FOR ALL SURVEYING:

PROJECT CONTROL

POSITIONING METHOD: ODOT VRS
 MONUMENT TYPE: TYPE 13

VERTICAL POSITIONING

ORTHOMETRIC HEIGHT DATUM: NAVD 88
 GEOID: GEOID 1213

HORIZONTAL POSITIONING

REFERENCE FRAME: NAD83 (2011)
 ELLIPSOID: GR580
 MAP PROJECTION: LAMBERT CONFORMAL CONIC
 COORDINATE SYSTEM: OHIO STATE PLANE, SOUTH ZONE
 COMBINED SCALE FACTOR: 1.00002576
 ORIGIN OF COORDINATE SYSTEM: 0,0

USE THE POSITIONING METHODS AND MONUMENT TYPE USED IN THE ORIGINAL SURVEY TO RESTORE ALL MONUMENTS RELATED TO PRIMARY PROJECT CONTROL THAT ARE DAMAGED OR DESTROYED BY CONSTRUCTION ACTIVITIES. RESTORE THE DAMAGED OR DESTROYED MONUMENTS IN ACCORDANCE WITH CMS 623.

UNITS ARE IN U.S. SURVEY FEET.

WORK LIMITS

THE WORK LIMITS SHOWN ON THESE PLANS ARE FOR PHYSICAL CONSTRUCTION ONLY. PROVIDE THE INSTALLATION AND OPERATION OF ALL WORK ZONE TRAFFIC CONTROL AND WORK ZONE TRAFFIC CONTROL DEVICES REQUIRED BY THESE PLANS WHETHER INSIDE OR OUTSIDE THESE WORK LIMITS.

CONSTRUCTION NOISE

ACTIVITIES AND LAND USE ADJACENT TO THIS PROJECT MAY BE AFFECTED BY CONSTRUCTION NOISE. IN ORDER TO MINIMIZE ANY ADVERSE CONSTRUCTION NOISE IMPACTS, DO NOT OPERATE POWER-OPERATED CONSTRUCTION-TYPE DEVICES BETWEEN THE HOURS OF 10 PM AND 6 AM. IN ADDITION, DO NOT OPERATE AT ANY TIME ANY DEVICE IN SUCH A MANNER THAT THE NOISE CREATED SUBSTANTIALLY EXCEEDS THE NOISE CUSTOMARILY AND NECESSARILY ATTENDANT TO THE REASONABLE AND EFFICIENT PERFORMANCE OF SUCH EQUIPMENT.

PART-WIDTH CONSTRUCTION

BECAUSE OF THE NECESSITY TO BUILD THIS PROJECT UNDER TRAFFIC AND TO CONSTRUCT THE FULL PAVEMENT WIDTH IN STAGES, EXERCISE CARE TO PREVENT THE CONSTRUCTION OF A BUTT JOINT IN THE BASE COURSES. LAP LONGITUDINAL JOINTS AS SHOWN ON STANDARD CONSTRUCTION DRAWING BP-3.1.

SEEDING AND MULCHING

THE FOLLOWING QUANTITIES ARE PROVIDED TO PROMOTE GROWTH AND CARE OF PERMANENT SEEDED AREAS:

| | |
|----------------------------|-------------|
| 659, TOPSOIL | 37 CU. YD. |
| 659, SEEDING AND MULCHING | 489 SQ. YD. |
| 659, COMMERCIAL FERTILIZER | 0.05 TON |
| 659, WATER | 1 M. GAL. |

SEEDING AND MULCHING SHALL BE APPLIED TO ALL AREAS OF EXPOSED SOIL BETWEEN THE RIGHT-OF-WAY LINES, AND WITHIN THE CONSTRUCTION LIMITS FOR AREAS OUTSIDE THE RIGHT-OF-WAY LINES COVERED BY WORK AGREEMENT OR SLOPE EASEMENT. QUANTITY CALCULATIONS FOR SEEDING AND MULCHING ARE BASED ON THESE LIMITS.

ITEM 202 - REMOVAL, MISC: LANDSCAPE WALL REMOVED

THE CONTRACTOR SHALL REMOVE LANDSCAPE WALL AT LOCATION SHOWN ON SHEET 9. REMOVAL SHALL BE PER ITEM 202. ALL MATERIALS, LABOR AND EQUIPMENT REQUIRED TO COMPLETE THE WORK DESCRIBED ABOVE SHALL BE INCLUDED UNDER THE UNIT BID PRICE FOR ITEM 202 - REMOVAL MISC.: LANDSCAPE WALL REMOVED

CROSSINGS AND CONNECTIONS TO EXISTING PIPES AND UTILITIES

WHERE PLANS PROVIDE FOR A PROPOSED CONDUIT TO BE CONNECTED TO, OR CROSS OVER OR UNDER AN EXISTING SEWER OR UNDERGROUND UTILITY, THE CONTRACTOR SHALL LOCATE THE EXISTING PIPES OR UTILITIES BOTH AS TO LINE AND GRADE BEFORE STARTING TO LAY THE PROPOSED CONDUIT.

IF IT IS DETERMINED THAT THE ELEVATION OF THE EXISTING CONDUIT, OR EXISTING APPURTENANCE TO BE CONNECTED, DIFFERS FROM THE PLAN ELEVATION OR RESULTS IN A CHANGE IN THE PLAN CONDUIT SLOPE, THE ENGINEER SHALL BE NOTIFIED BEFORE STARTING CONSTRUCTION OF ANY PORTION OF THE PROPOSED CONDUIT WHICH WILL BE AFFECTED BY THE VARIANCE IN THE EXISTING ELEVATIONS.

IF IT IS DETERMINED THAT THE PROPOSED CONDUIT WILL INTERSECT AN EXISTING SEWER OR UNDERGROUND UTILITY IF CONSTRUCTED AS SHOWN ON THE PLAN, THE ENGINEER SHALL BE NOTIFIED BEFORE STARTING CONSTRUCTION OF ANY PORTION OF THE PROPOSED CONDUIT WHICH WOULD BE AFFECTED BY THE INTERFERENCE WITH AN EXISTING FACILITY.

PAYMENT FOR ALL THE OPERATIONS DESCRIBED ABOVE SHALL BE INCLUDED IN THE CONTRACT PRICE FOR THE PERTINENT 611 CONDUIT ITEM.

MATERIAL STAGING AREA

THE CONTRACTOR MAY UTILIZE THE EXISTING NORTHBOUND LANES OF COLUMBIA ROAD AS A STAGING AREA DURING PERIODS WHEN THE NORTHBOUND LANES ARE CLOSED TO TRAFFIC. THE CONTRACTOR SHALL ENSURE THAT NO MATERIALS OR EQUIPMENT ENCROACH INTO THE SOUTHBOUND LANES.

DESIGN AGENCY



DESIGNER
BTP

REVIEWER

BAA 06-28-21

PROJECT ID

COLUMBIA RD

SHEET TOTAL

3 | 24

ITEM 614 - MAINTAINING TRAFFIC

IT IS THE INTENTION TO PERFORM THE REQUIRED WORK WITH THE LEAST INCONVENIENCE TO, AND THE MAXIMUM SAFETY OF THE CONTRACTOR AND THE TRAVELING PUBLIC. THE REQUIREMENTS FOR MAINTAINING TRAFFIC AS SPECIFIED IN THE "OHIO MANUAL OF UNIFORM TRAFFIC CONTROL DEVICES, CURRENT EDITION", PERTINENT PROVISIONS OF THE "OHIO DEPARTMENT OF TRANSPORTATION CONSTRUCTION AND MATERIALS SPECIFICATIONS" (INCLUDING SUPPLEMENTAL SPECIFICATIONS) AND APPLICABLE STANDARD CONSTRUCTION DRAWINGS SHALL APPLY TO THIS PROJECT IN ADDITION TO THE FOLLOWING NOTES.

A MINIMUM OF ONE LANE OF TRAFFIC IN EACH DIRECTION SHALL BE MAINTAINED AT ALL TIMES, EXCEPT FOR A PERIOD NOT TO EXCEED 60 CONSECUTIVE CALENDAR DAYS, WHEN NORTHBOUND THROUGH TRAFFIC MAY BE DETOURED AS SHOWN ON SHEET 5.

ACCESS FOR ABUTTING PROPERTY OWNERS SHALL BE MAINTAINED AT ALL TIMES IN ACCORDANCE WITH THESE NOTES AND PLAN SPECIFICATIONS. THE CONTRACTOR SHALL WORK WITH THE PROPERTY OWNERS TO MAINTAIN SPECIAL ACCESS PROVISIONS.

LENGTH AND DURATION OF LANE CLOSURES AND RESTRICTIONS SHALL BE AT THE APPROVAL OF THE ENGINEER. IT IS THE INTENT TO MINIMIZE THE IMPACT TO THE TRAVELING PUBLIC. LANE CLOSURES OR RESTRICTIONS OVER SEGMENTS OF THE PROJECT IN WHICH NO WORK IS ANTICIPATED WITHIN A REASONABLE TIME FRAME, AS DETERMINED BY THE ENGINEER, SHALL NOT BE PERMITTED. THE LEVEL OF UTILIZATION OF MAINTENANCE OF TRAFFIC DEVICES SHALL COMMENSURATE WITH THE WORK IN PROGRESS.

LANE CLOSURES ARE NOT PERMITTED ON US 22/3 BETWEEN THE HOURS 12 P.M. AND 7 P.M.

NOTICE OF CLOSURE SIGNS (W20-H13) SHALL BE ERECTED BY THE CONTRACTOR PRIOR TO THE SCHEDULED ROAD CLOSURE IN ACCORDANCE WITH THE NOTICE OF CLOSURE TIME TABLE BELOW.

THE SIGNS SHALL BE ERECTED ON THE RIGHT-HAND SIDE OF THE ROAD FACING TRAFFIC. THEY SHALL BE PLACED SO AS NOT TO INTERFERE WITH THE VISIBILITY OF ANY OTHER TRAFFIC CONTROL DEVICES. THEY SHOULD BE ERECTED AT OR NEAR THE POINT OF CLOSURE.

| NOTICE TO CLOSURE SIGN TIME TABLE | | |
|-----------------------------------|------------------------|-----------------------------------|
| ITEM | DURATION OF CLOSURE | SIGN DISPLAYED TO PUBLIC |
| ROAD CLOSURE | >= 2 WEEKS | 14 CALENDAR DAYS PRIOR TO CLOSURE |
| | > 12 HOURS & < 2 WEEKS | 7 CALENDAR DAYS PRIOR TO CLOSURE |
| | < 12 HOURS | 2 CALENDAR DAYS PRIOR TO CLOSURE |

THE SIGN SHALL DISPLAY THE DATE OF THE CLOSURE IN MMM-DD FORMAT AND THE NUMBER OF DAYS OF THE CLOSURE. THE LAST LINE OF THE W0-H13 SIGN LISTS A PHONE NUMBER WHICH A MOTORIST MAY CALL FOR ADDITIONAL INFORMATION. THIS IS TO BE A SPECIFIC OFFICE WITHIN THE COUNTY RATHER THAN THE GENERAL SWITCHBOARD NUMBER.

THE CONTRACTOR SHALL PROVIDE ONE-WAY SIGNS (R6-1L OR 1R) AT THE EXIT OF EACH DRIVE ON COLUMBIA ROAD, DIRECTING TRAFFIC TO THE SOUTH. THE SIGN SHALL BE 36 X 12 INCH IN SIZE WITH TYPE G OR TYPE H ORANGE RETROREFLECTIVE SHEETING.

ITEM 614 - MAINTAINING TRAFFIC (CONT.)

THE SIGNS SHALL BE MOUNTED ON TWO #3 POSTS OR ON TEMPORARY POSTS IN ACCORDANCE WITH SCD MT-105.10 AND IN ACCORDANCE WITH THE OHIO MANUAL OF UNIFORM TRAFFIC CONTROL DEVICES, CURRENT EDITION. THE SIGN SHALL BE CLEARLY VISIBLE AND SHALL CLEARLY IDENTIFY THE LOCATION OF THE DRIVEWAY. THE SIGN SHOULD BE POSITIONED AT 90 DEGREES TO THE DIRECTION(S) OF TRAFFIC. THE SIGN MAY NEED TO BE MOVED FOR EACH PHASE OF THE MAINTENANCE OF TRAFFIC OPERATIONS.

THE CONTRACTOR SHALL PROVIDE, ERECT AND MAINTAIN STANDARD 48 x 30 INCH ROAD CLOSED SIGNS, SIGN SUPPORTS, BARRICADES AND LIGHTS, AS DETAILED IN SCD MT-101.60 AT THE LOCATIONS DESCRIBED IN THESE NOTES DURING PERIODS IN WHICH THE AFFECTED ROADS ARE CLOSED TO TRAFFIC.

THE CONTRACTOR SHALL PROVIDE, ERECT AND MAINTAIN SIGNS AND SIGN SUPPORTS, AS DETAILED IN THE OHIO MANUAL OF UNIFORM TRAFFIC CONTROL DEVICES, AND TYPE III BARRICADES OF THE TYPE AND LOCATION SHOWN IN THE DETOUR PLAN.

ALL WORK AND TRAFFIC CONTROL DEVICES SHALL BE IN ACCORDANCE WITH C&MS 614 AND OTHER APPLICABLE PORTIONS OF THE SPECIFICATIONS, AS WELL AS THE OHIO MANUAL OF UNIFORM TRAFFIC CONTROL DEVICES. PAYMENT FOR ALL LABOR, EQUIPMENT AND MATERIALS SHALL BE INCLUDED IN THE LUMP SUM CONTRACT PRICE FOR ITEM 614 - MAINTAINING TRAFFIC, UNLESS SEPARATELY ITEMIZED IN THE PLAN.

NOTIFICATION OF TRAFFIC RESTRICTIONS

THROUGHOUT THE DURATION OF THE PROJECT, THE CONTRACTOR SHALL NOTIFY THE PROJECT ENGINEER IN WRITING OF ALL TRAFFIC RESTRICTIONS AND UPCOMING MAINTENANCE OF TRAFFIC CHANGES. THE CONTRACTOR SHALL ENSURE THE WRITTEN NOTIFICATION IS SUBMITTED IN A TIMELY MANNER TO ALLOW THE PROJECT ENGINEER TO MEET THE REQUIRED TIME FRAMES SET FORTH IN THE TABLE BELOW TO INFORM THE SPECIAL HAULING PERMITS SECTION (HAULING.PERMITS@DOT.OHIO.GOV) AND THE DISTRICT PUBLIC INFORMATION OFFICE (PIO). THIS NOTIFICATION SHALL BE RECEIVED BY THE PROJECT ENGINEER PRIOR TO THE PHYSICAL SETUP OF ANY APPLICABLE SIGNS OR MESSAGE BOARDS.

INFORMATION SHOULD INCLUDE, BUT IS NOT LIMITED TO, ALL CONSTRUCTION ACTIVITIES THAT IMPACT OR INTERFERE WITH TRAFFIC AND SHALL LIST THE SPECIFIC LOCATION, TYPE OF WORK, ROAD STATUS, DATE AND TIME OF RESTRICTION, DURATION OF RESTRICTION, NUMBER OF LANES MAINTAINED, NUMBER OF LANES CLOSED, MINIMUM VERTICAL CLEARANCE, MINIMUM WIDTH OF DRIVABLE PAVEMENT, DETOUR ROUTES, IF APPLICABLE, AND ANY OTHER INFORMATION REQUESTED BY THE PROJECT ENGINEER.

| NOTIFICATION TIME TABLE | | |
|------------------------------|------------------------|--|
| ITEM | DURATION OF CLOSURE | SIGN DISPLAYED TO PUBLIC |
| ROAD CLOSURE | >= 2 WEEKS | 14 CALENDAR DAYS PRIOR TO CLOSURE |
| | > 12 HOURS & < 2 WEEKS | 7 CALENDAR DAYS PRIOR TO CLOSURE |
| | < 12 HOURS | 2 CALENDAR DAYS PRIOR TO CLOSURE |
| LANE CLOSURES & RESTRICTIONS | >= 2 WEEKS | 14 CALENDAR DAYS PRIOR TO CLOSURE |
| | < 2 WEEKS | 5 CALENDAR DAYS PRIOR TO CLOSURE |
| LANE CLOSURES & RESTRICTIONS | N/A | 14 CALENDAR DAYS PRIOR TO IMPLEMENTATION |

ANY UNFORESEEN CONDITIONS NOT SPECIFIED IN THE PLANS REQUIRING TRAFFIC RESTRICTIONS SHALL ALSO BE REPORTED TO THE PROJECT ENGINEER USING THE NOTIFICATION TIME TABLE.

ITEM 614 - BUSINESS ENTRANCE (M4-H15) SIGN, AS PER PLAN

THE CONTRACTOR SHALL PROVIDE A BUSINESS ENTRANCE SIGN (M4-H15) AT THE STRIP MALL ENTRANCE DRIVE, LOCATED JUST SOUTH OF THE BEGINNING OF THE FULL-DEPTH PAVEMENT REPLACEMENT. ONLY ONE SIGN PER BUSINESS SHALL BE PERMITTED. THE SIGN SHALL BE 36 x 48 INCH IN SIZE WITH TYPE G OR TYPE H ORANGE RETROREFLECTIVE SHEETING. THE SIGN LEGEND SHALL BE PLACED ON BOTH SIDES OF THE SIGN (BACK TO BACK). THE SIGN SHALL HAVE THE STANDARD M4-H15 LEGEND WITH THE WORD "BUSINESS" ON THE TOP LINE, EXCEPT UNDER UNUSUAL CIRCUMSTANCES WHERE IT MAY NOT BE INTUITIVE THAT A DRIVEWAY SERVES A SPECIFIC BUSINESS. IN SUCH UNUSUAL CASES, THE ACTUAL BUSINESS NAME MAY BE SUBSTITUTED FOR THE WORD "BUSINESS".

THE SIGNS SHALL BE MOUNTED ON TWO #3 POSTS OR ON TEMPORARY POSTS IN ACCORDANCE WITH SCD MT-105.10 AND IN ACCORDANCE WITH THE OHIO MANUAL OF UNIFORM TRAFFIC CONTROL DEVICES, CURRENT EDITION. THE SIGN SHALL BE CLEARLY VISIBLE AND SHALL CLEARLY IDENTIFY THE LOCATION OF THE DRIVEWAY. THE SIGN SHOULD BE POSITIONED AT 90 DEGREES TO THE DIRECTION(S) OF TRAFFIC. THE SIGN MAY NEED TO BE MOVED FOR EACH PHASE OF THE MAINTENANCE OF TRAFFIC OPERATIONS.

PAYMENT FOR ALL COSTS ASSOCIATED WITH MANUFACTURING, MOUNTING, RELOCATING, AND REMOVING THE SIGN, INCLUDING ALL LABOR, MATERIALS AND EQUIPMENT SHALL BE INCLUDED IN THE CONTRACT PRICE PER EACH FOR ITEM 614 - BUSINESS ENTRANCE SIGN.

THE FOLLOWING ESTIMATED QUANTITY HAS BEEN CARRIED TO THE GENERAL SUMMARY FOR THIS ITEM:

ITEM 614 - BUSINESS ENTRANCE SIGN 1 EACH

ITEM 614 - DETOUR SIGNING

THE CONTRACTOR SHALL FURNISH, ERECT, MAINTAIN AND REMOVE DETOUR SIGNING. PAYMENT FOR ALL MATERIAL, LABOR AND EQUIPMENT TO IMPLEMENT THE DETOUR SIGNING SHALL BE INCLUDED IN THE LUMP SUM BID FOR ITEM 614 - DETOUR SIGNING.

DESIGN AGENCY



DESIGNER

DMG

REVIEWER

BAA 06-28-21

PROJECT ID

COLUMBIA RD

SHEET TOTAL

4 24

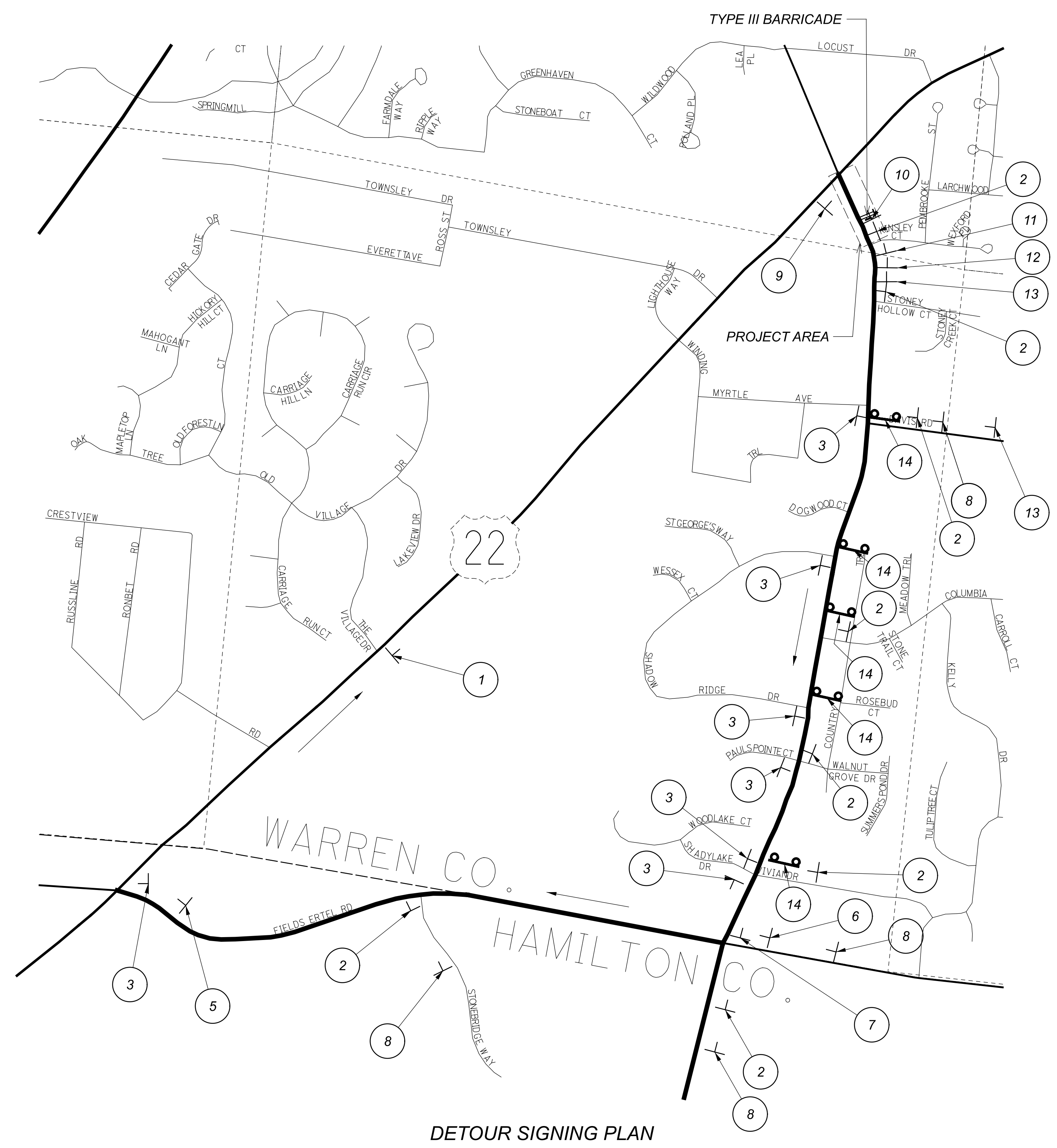
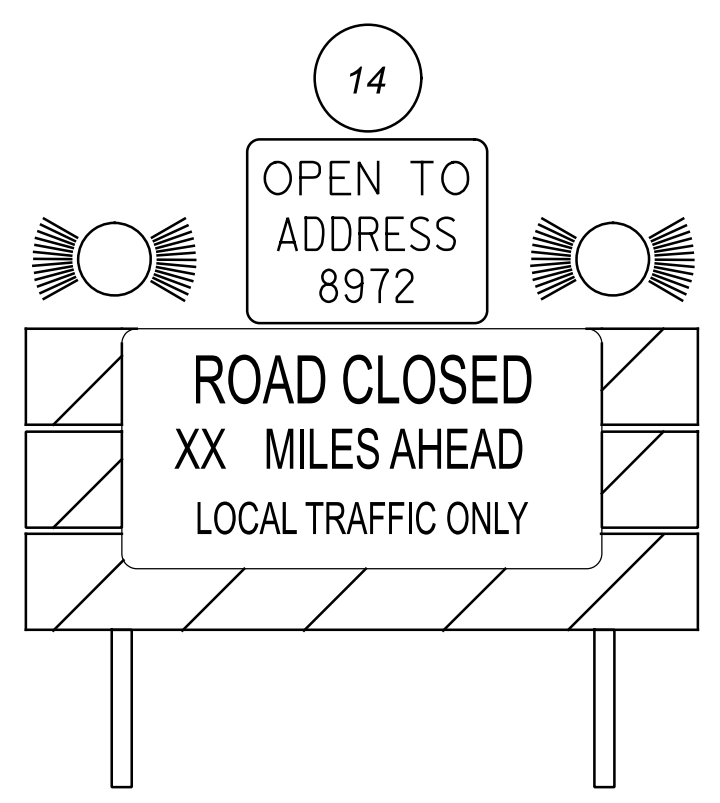
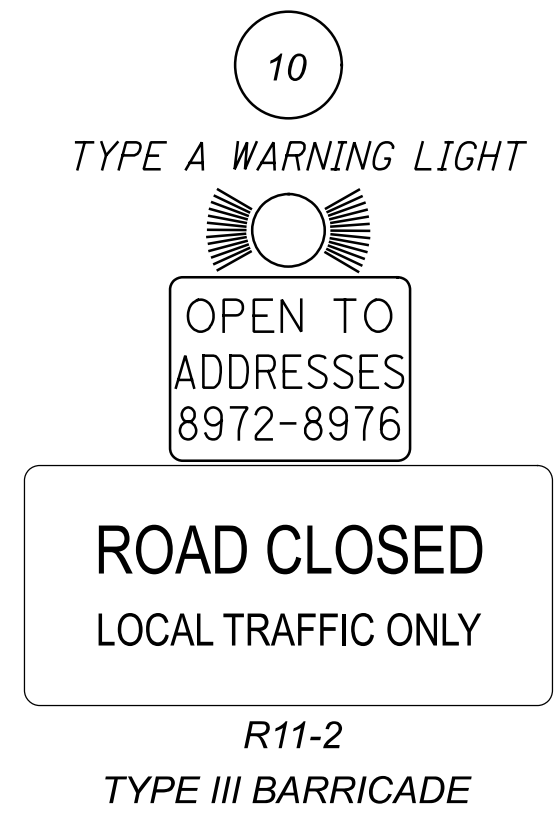
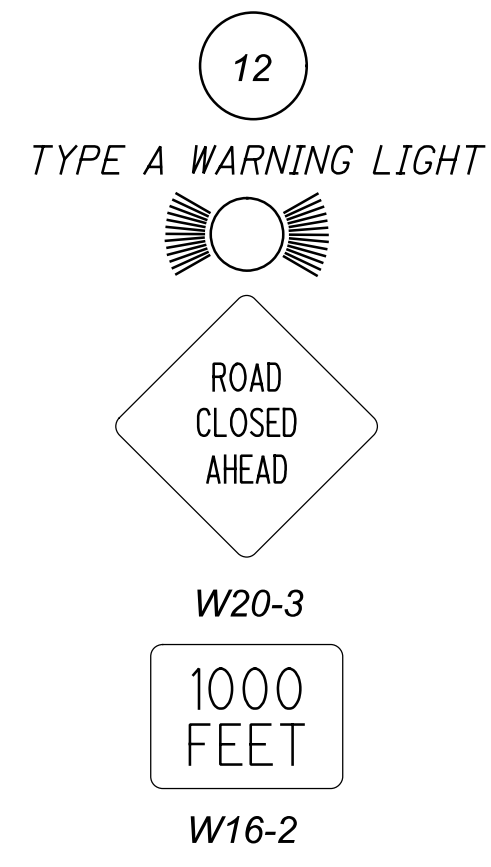
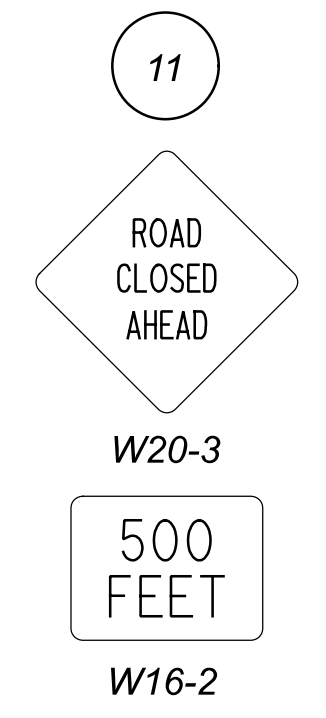
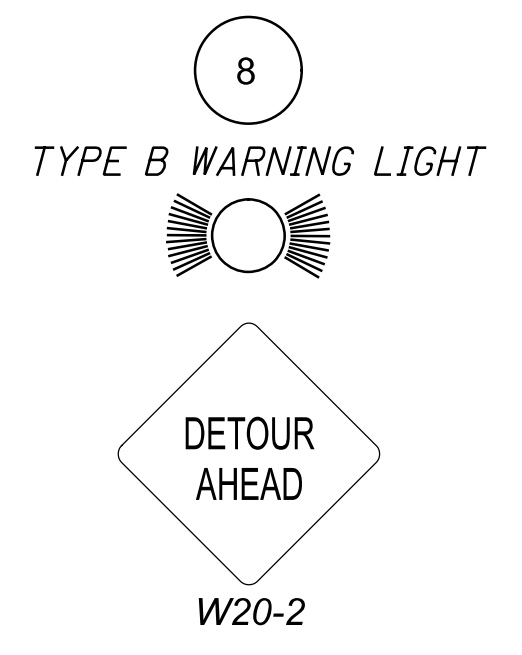
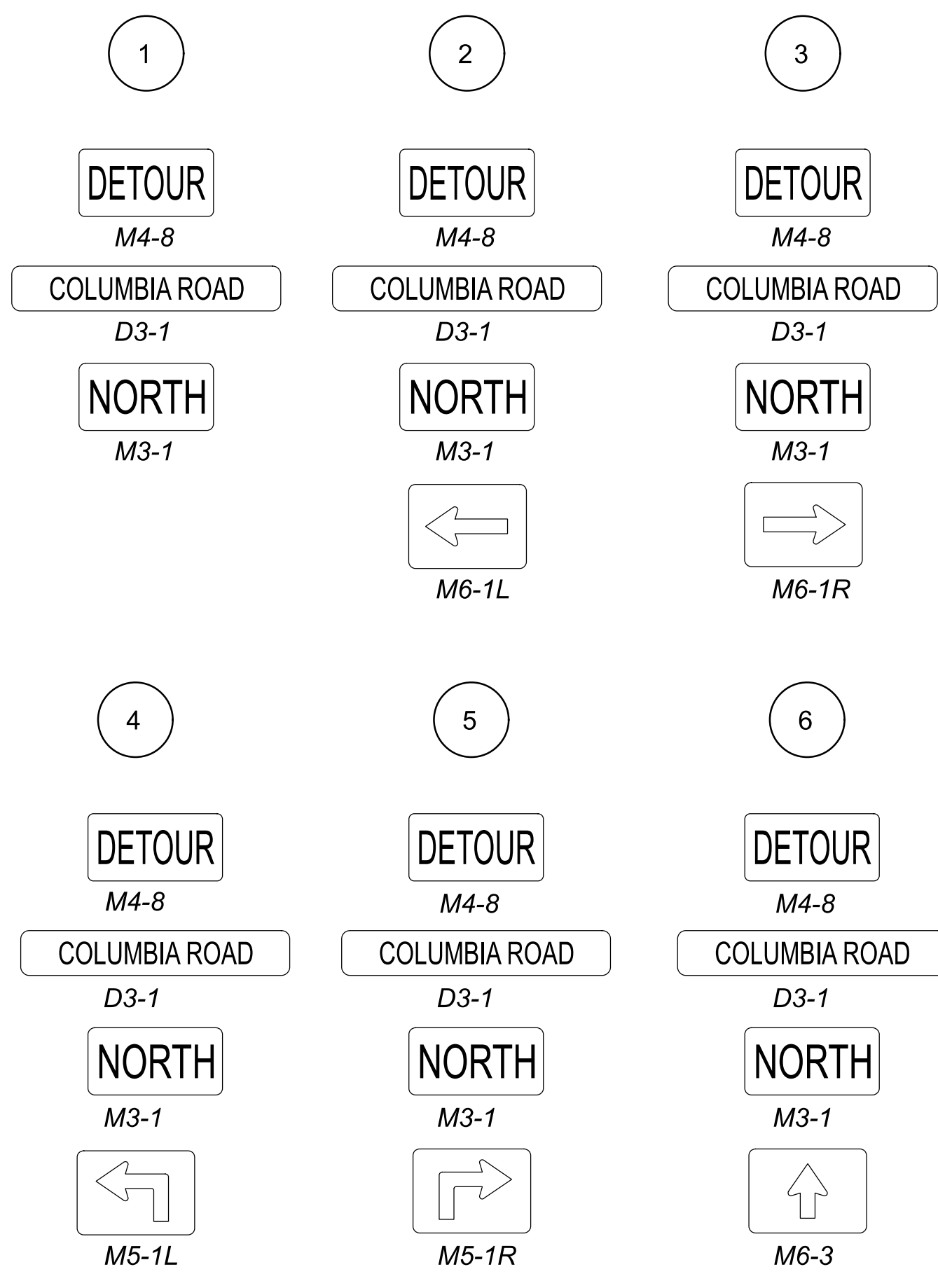

| | |
|-----------------|--------------|
| DESIGN AGENCY | |
| CARPENTER MARTY | |
| DESIGNER | WCS |
| REVIEWER | BAA 06/28/21 |
| PROJECT ID | COLUMBIA RD |
| SUBSET | TOTAL |
| SHEET | TOTAL |
| 5 | 24 |

PROPOSED DRAINAGE STRUCTURES

| ID | TYPE | STATION | OFFSET | GRATE ELEV. | INVERT ELEV |
|----|--------|----------|-----------|-------------|----------------------|
| D1 | CB-3A | 8+58.66 | 34.88' RT | 838.61 | 12" - 836.37 (N) |
| D2 | CB-3A | 8+82.98 | 31.00' RT | 837.97 | 12" - 836.25 (W & S) |
| D3 | EX. CB | 8+79.53± | 19.97± LT | 838.59± | 12" - 836.01 (E) |

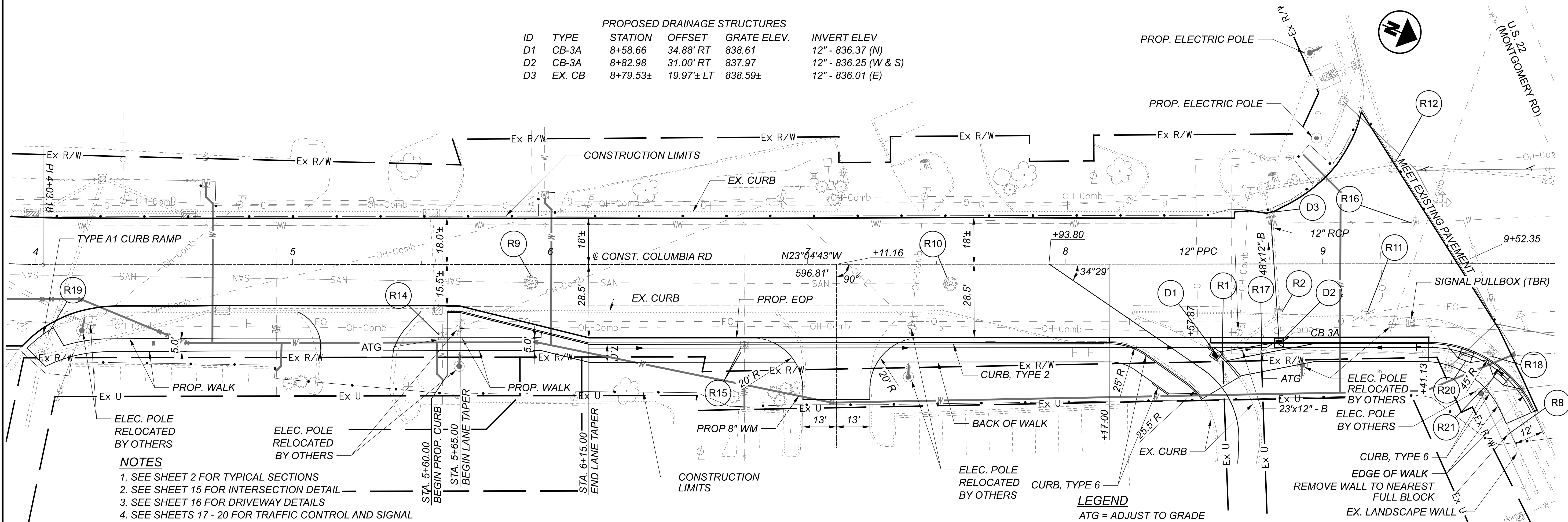

NOTES

1. SEE SHEET 2 FOR TYPICAL SECTIONS
2. SEE SHEET 15 FOR INTERSECTION DETAIL
3. SEE SHEET 16 FOR DRIVEWAY DETAILS
4. SEE SHEETS 17 - 20 FOR TRAFFIC CONTROL AND SIGNAL

LEGEND
 ATG = ADJUST TO GRADE

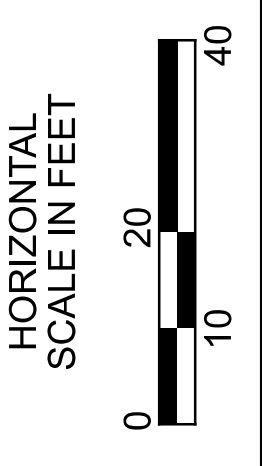
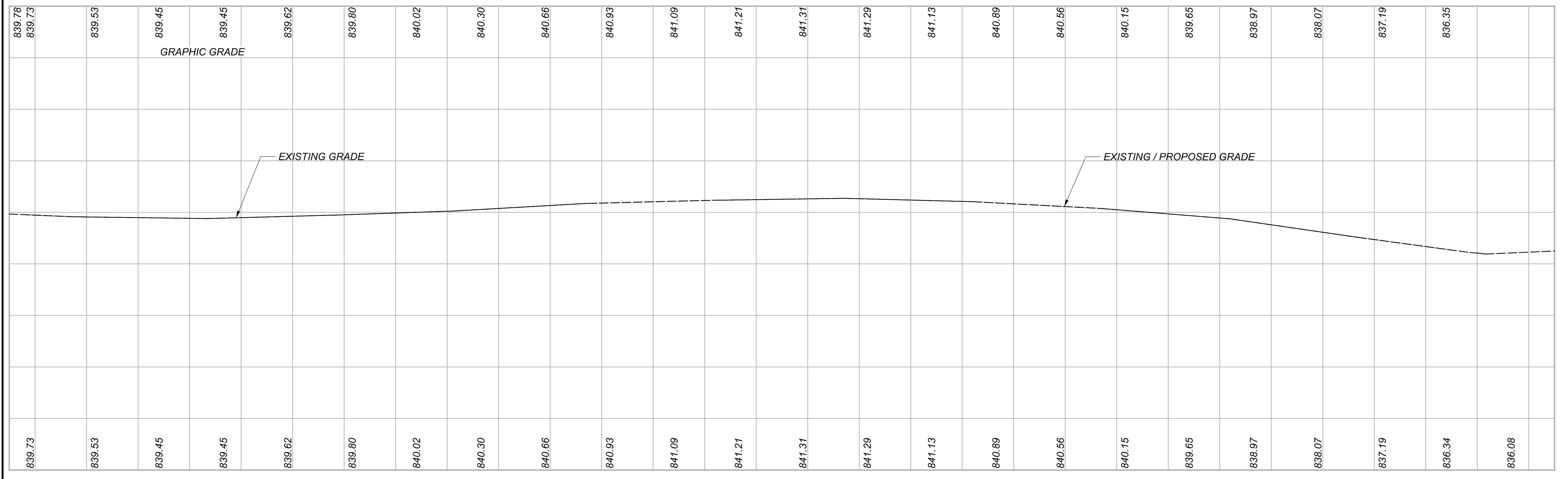

PLAN AND PROFILE
 COLUMBIA ROAD

DESIGN AGENCY

 DESIGNER
 DMG
 REVIEWER
 BAA 06/28/21
 PROJECT ID
 COLUMBIA RD
 SHEET TOTAL
 9 24

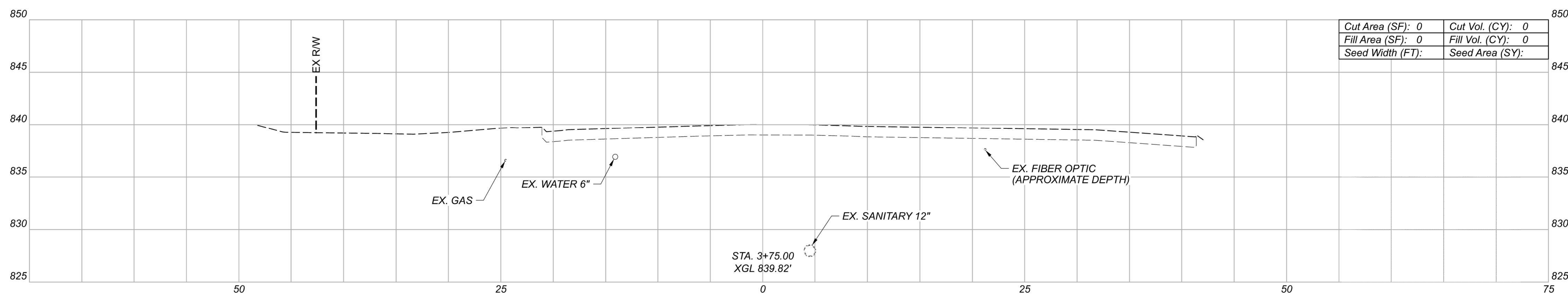
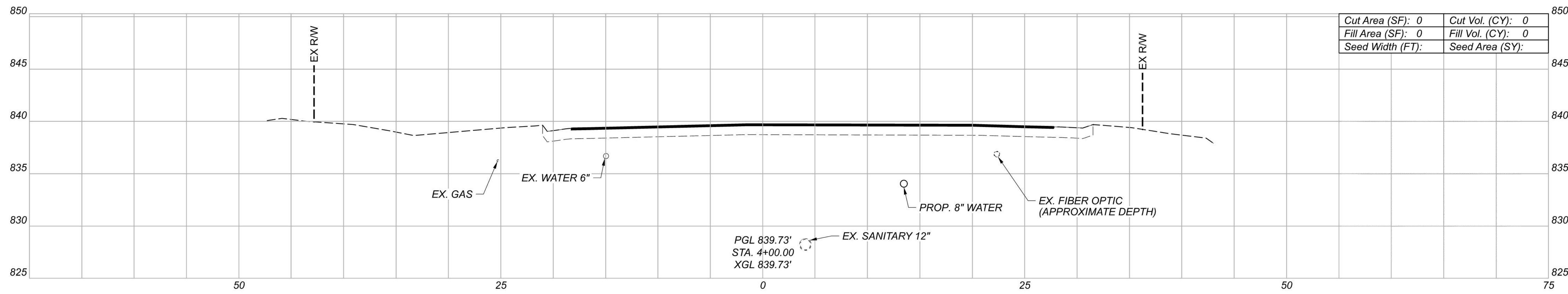
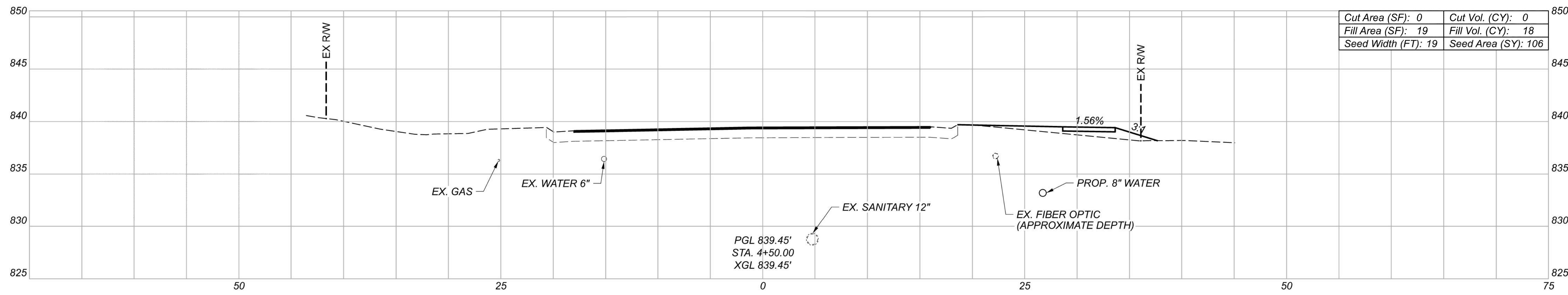

CROSS SECTIONS
 STA. 3+75 TO STA. 4+50

DESIGN AGENCY

 DESIGNER
 WCS
 REVIEWER
 BAA 06/28/21
 PROJECT ID
 COLUMBIA RD
 SHEET TOTAL
 10 24

| Sheet Totals | | |
|--------------|-----|------|
| Seeding | Cut | Fill |
| 106 | 0 | 18 |

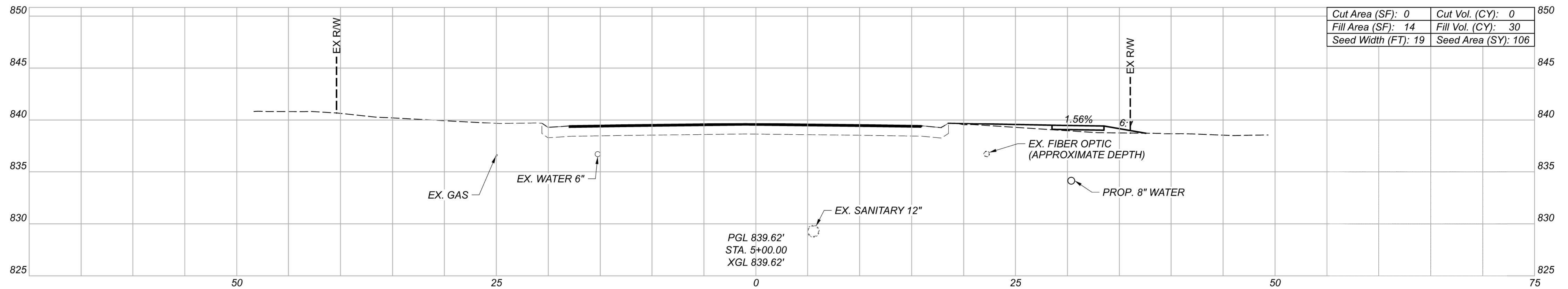
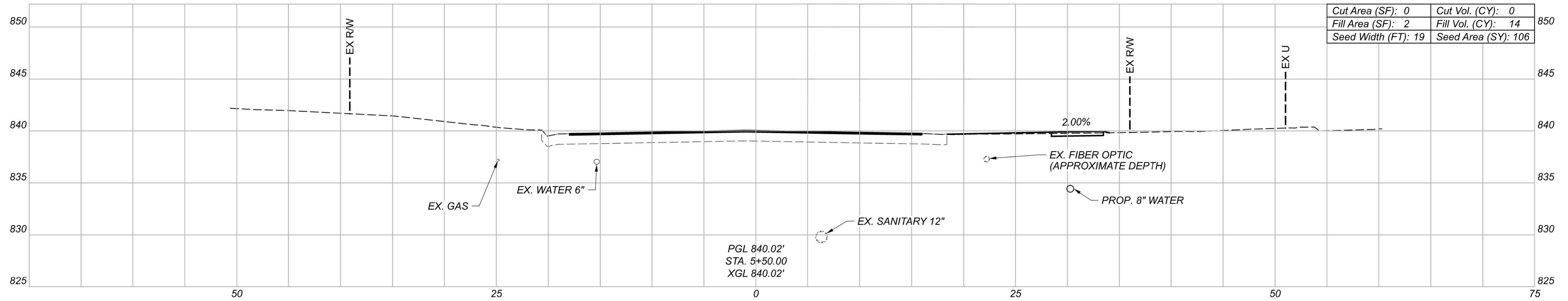
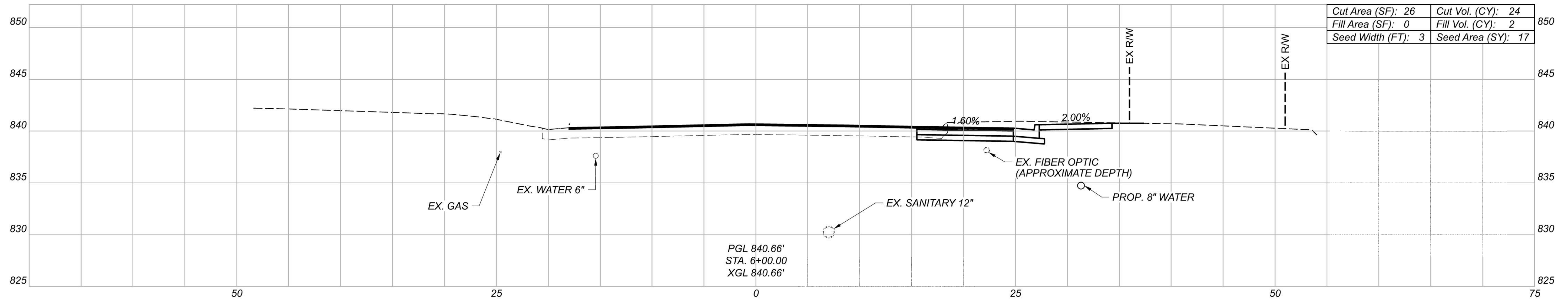

CROSS SECTIONS
 STA. 5+00 TO 6+00

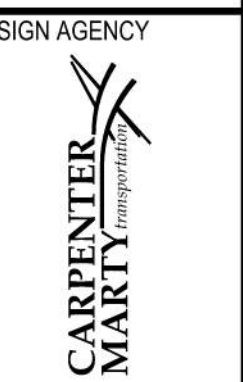

DESIGNER
 WCS

REVIEWER
 BAA 06/28/21

PROJECT ID
 COLUMBIA RD

| Sheet Totals | | | SHEET | TOTAL |
|--------------|-----|------|-------|-------|
| Seeding | Cut | Fill | | |
| 229 | 24 | 46 | 11 | 24 |

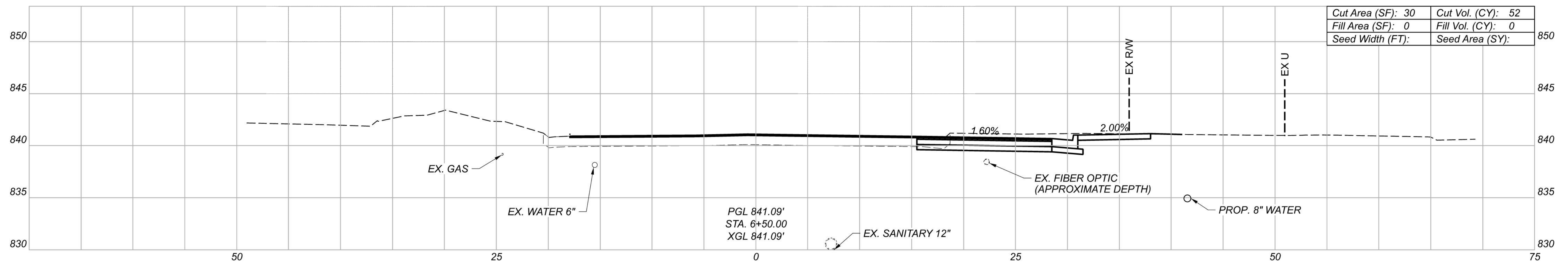
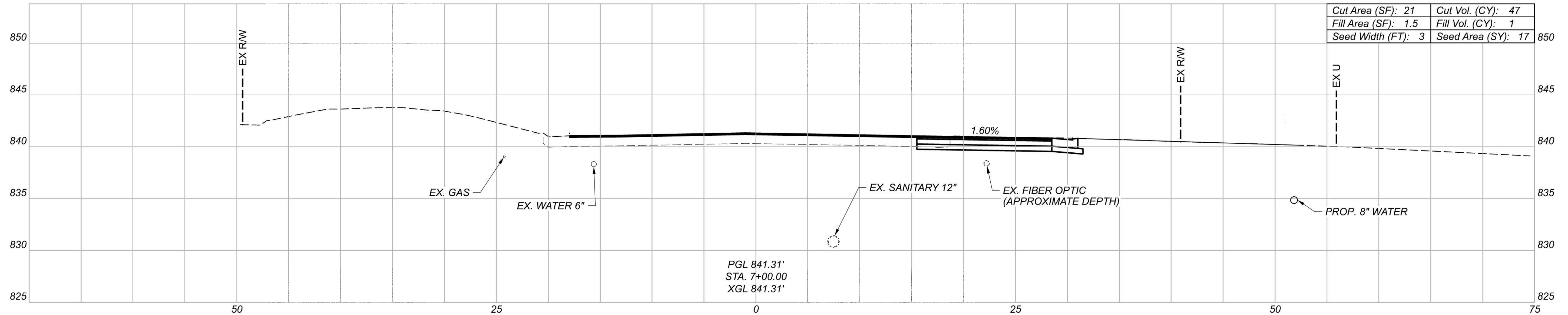
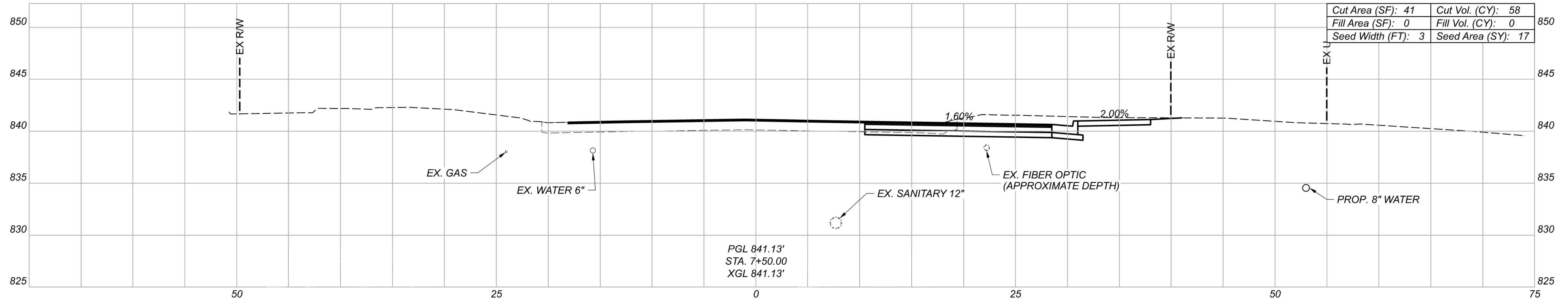

CROSS SECTIONS
 STA. 6+50 TO STA. 7+50

DESIGN AGENCY

 CARPENTER
 MARTY

DESIGNER
 WCS

REVIEWER

BAA 06/28/21

PROJECT ID

COLUMBIA RD

| Sheet Totals | | | SHEET | TOTAL |
|--------------|-----|------|-------|-------|
| Seeding | Cut | Fill | | |
| 34 | 157 | 1 | 12 | 24 |

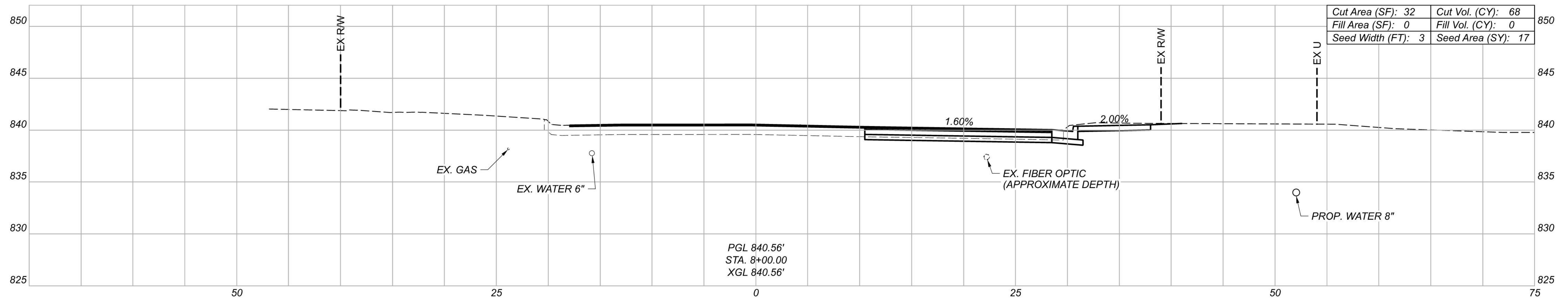
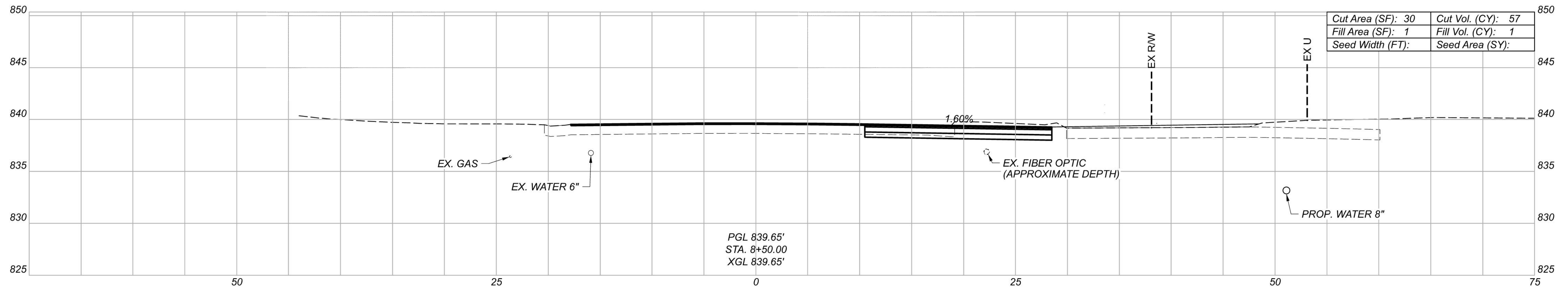
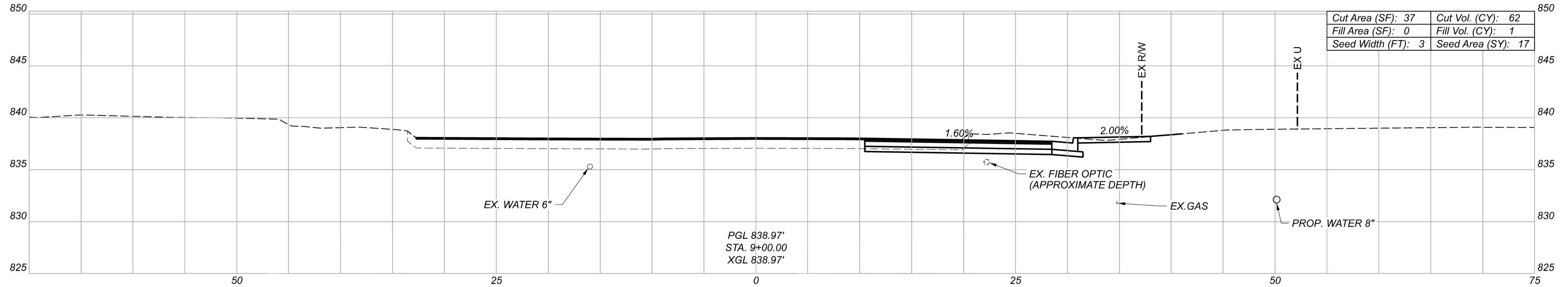

CROSS SECTIONS
 STA. 8+00 TO STA. 9+00



DESIGN AGENCY

DESIGNER

WCS

REVIEWER

BAA 06/28/21

PROJECT ID

COLUMBIA RD

| Sheet Totals | | | SHEET | TOTAL |
|--------------|-----|------|-------|-------|
| Seeding | Cut | Fill | | |
| 34 | 187 | 2 | 13 | 24 |

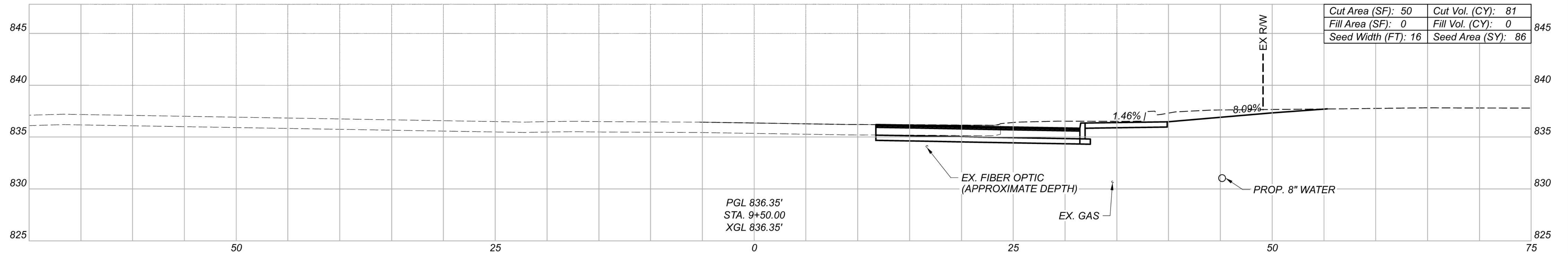

PGL 836.35'
 STA. 9+50.00
 XGL 836.35'

| | |
|---------------------|--------------------|
| Cut Area (SF): 50 | Cut Vol. (CY): 81 |
| Fill Area (SF): 0 | Fill Vol. (CY): 0 |
| Seed Width (FT): 16 | Seed Area (SY): 86 |

| Sheet Number | Earthwork Totals | | |
|-----------------------------------|------------------|----------|-----------|
| | Seeding (SY) | Cut (CY) | Fill (CY) |
| 10 | 106 | 0 | 18 |
| 11 | 229 | 24 | 46 |
| 12 | 34 | 157 | 1 |
| 13 | 34 | 187 | 2 |
| 14 | 86 | 81 | 0 |
| Totals Carried to General Summary | 489 | 449 | 67 |

| Sheet Totals | | | SHEET | TOTAL |
|--------------|-----|------|-------|-------|
| Seeding | Cut | Fill | | |
| 86 | 81 | 0 | 14 | 24 |

DESIGN AGENCY
CARPENTER MARTY
 DESIGNER
 WCS
 REVIEWER
 BAA 06/28/21
 PROJECT ID
 COLUMBIA RD

COLUMBIA ROAD

MODEL: Intersection Detail(Sheet) PAPER: 34x22 (in.) DATE: 2/22/2022 TIME: 3:41:36 PM USER: bockel
 P:\WAR\TR\0002\Columbia Rd\400-Engineering\Roadway\Sheets\Columbia Rd_G100.dgn

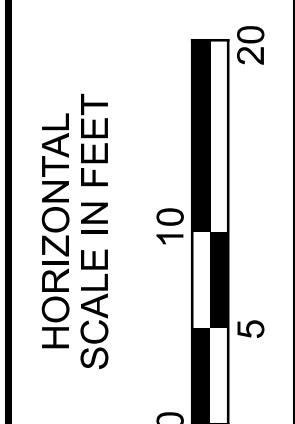
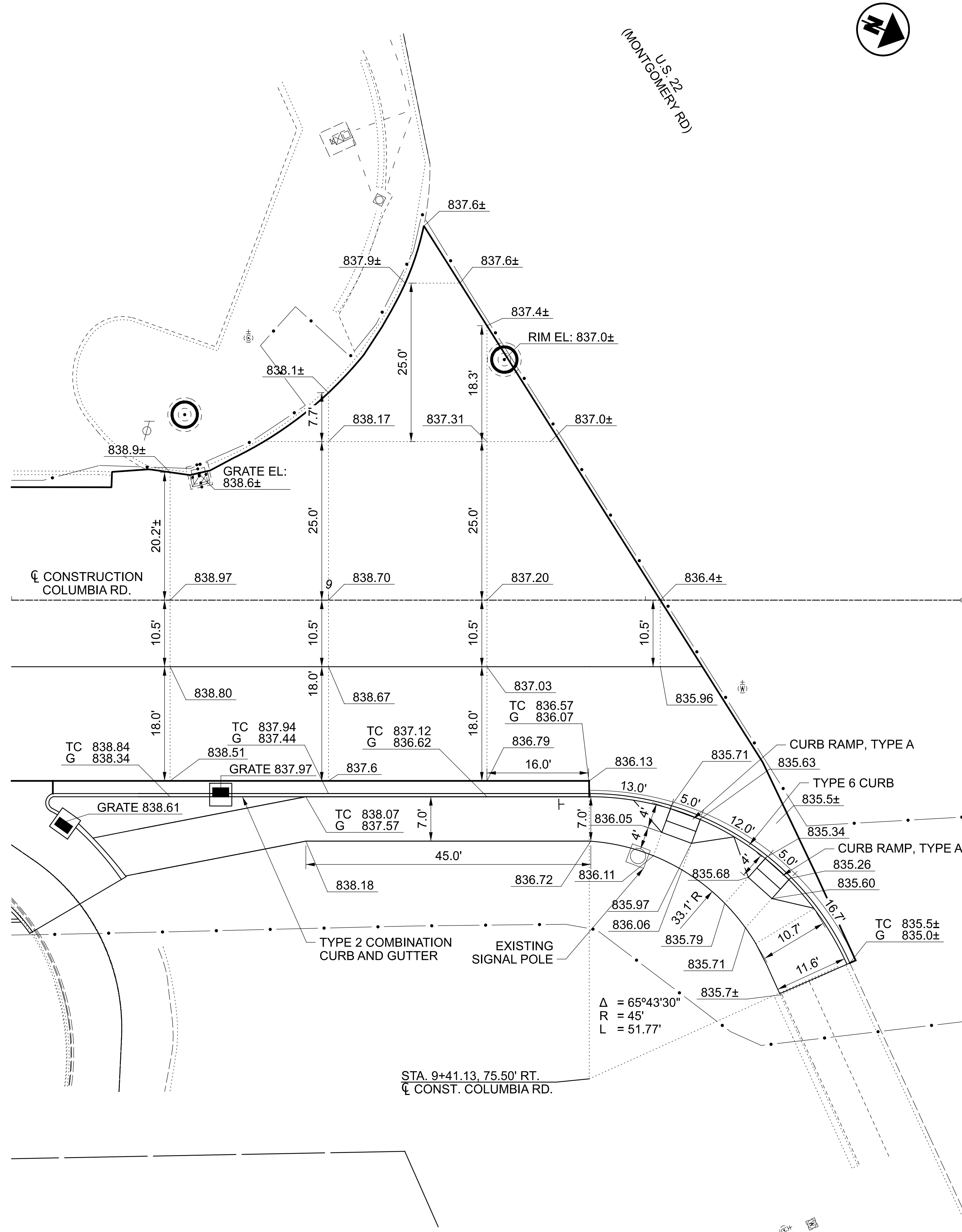

**INTERSECTION DETAIL
 COLUMBIA ROAD & MONTGOMERY ROAD (US-22/SR-3)**

| | |
|---------------|--------------|
| DESIGN AGENCY | |
| | |
| DESIGNER | BTP |
| REVIEWER | BAA 06/28/21 |
| PROJECT ID | COLUMBIA RD |
| SHEET | TOTAL |
| 15 | 24 |

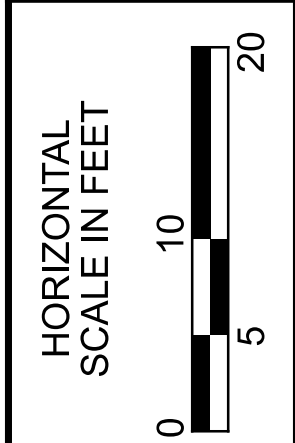
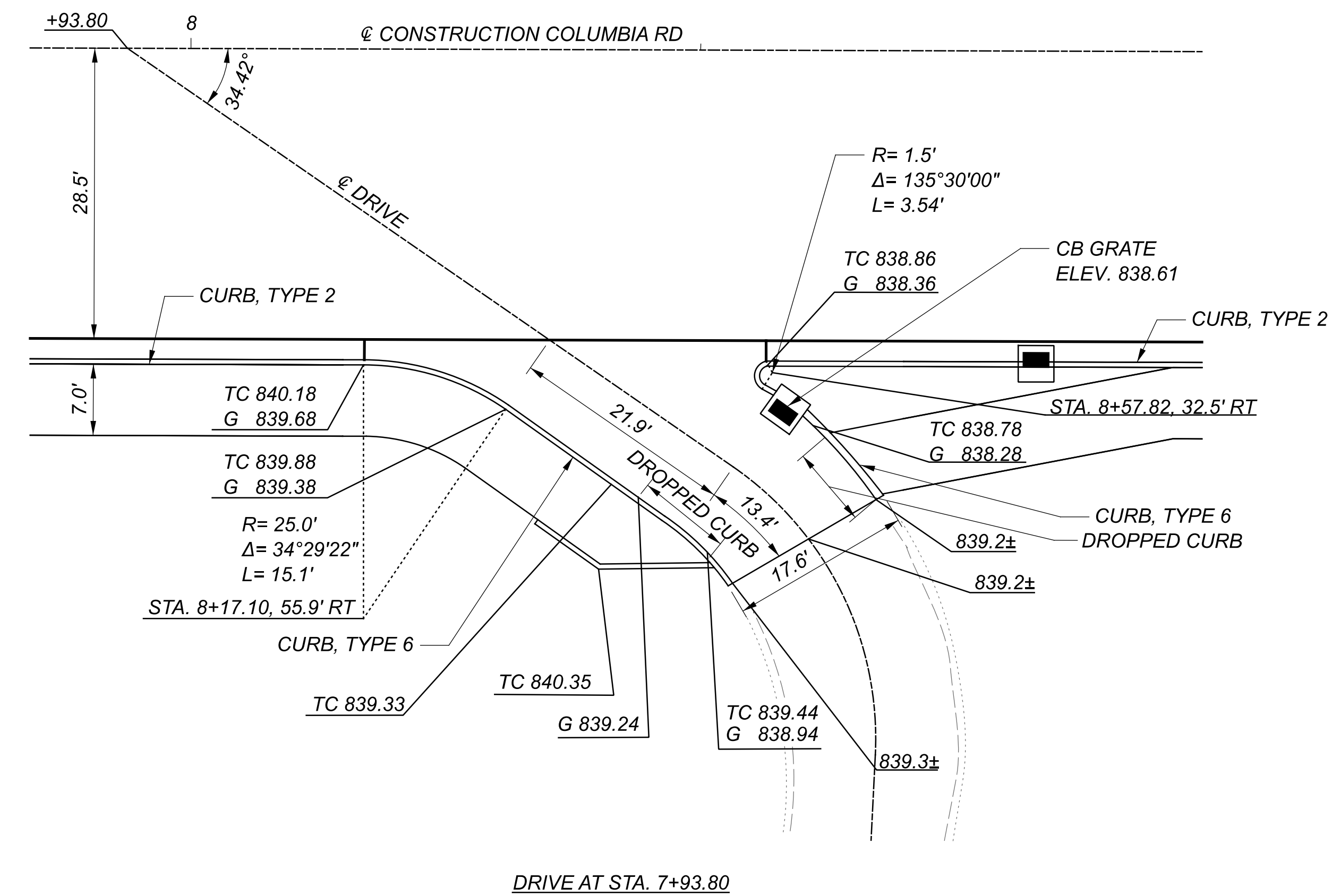
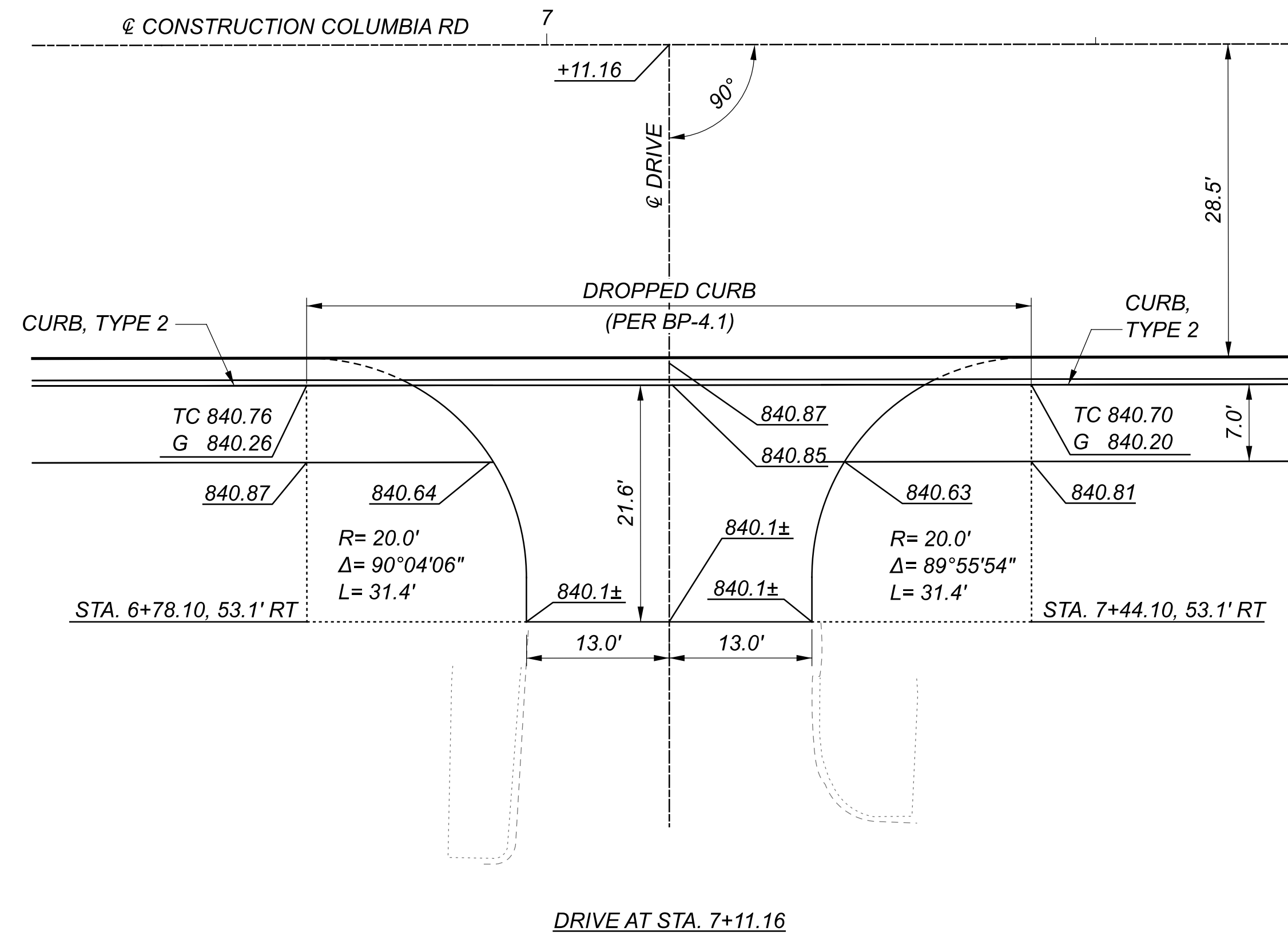

DRIVEWAY DETAILS
COLUMBIA ROAD

DESIGN AGENCY
CARPENTER
MARTY

DESIGNER
BTP

REVIEWER
BAA 06-28-21

PROJECT ID
COLUMBIA RD

| | |
|-------|-------|
| SHEET | TOTAL |
| 16 | 24 |

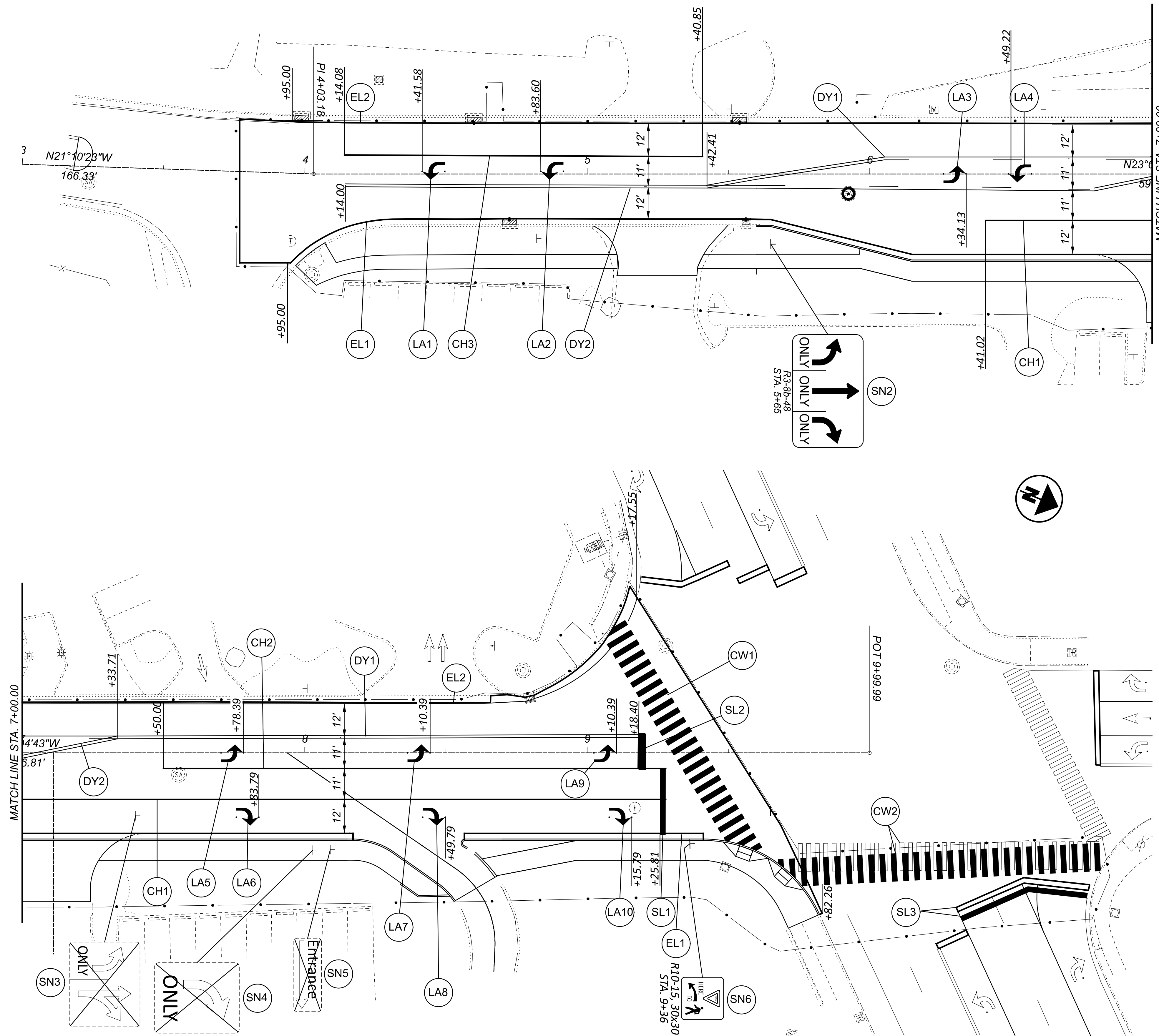

PAVEMENT MARKING LEGEND

- EL# ITEM 644 - EDGE LINE, 4", WHITE
- LA# ITEM 644 - LANE ARROW
- CH# ITEM 644 - CHANNELIZING LINE, 8"
- DY# ITEM 644 - DOUBLE YELLOW (SOLID)
- SL# ITEM 644 - STOP LINE
- CW# ITEM 644 - CROSSWALK LINE, SEE ODOT STD. DWG. TC-74.10

NOTES:
 1. FOR SIGNAL PLANS, SEE SHEETS 18 - 20.
 2. ALL EXISTING PAVEMENT MARKINGS TO BE REMOVED AND REPLACED BEGINNING AT STA. 3+95 THROUGH THE INTERSECTION AS SHOWN.



PAVEMENT MARKING PLAN
 COLUMBIA ROAD & MONTGOMERY ROAD (US-22/SR-3)

| | |
|---------------|-----------------|
| DESIGN AGENCY | CARPENTER MARTY |
| DESIGNER | BTP |
| REVIEWER | BAA 06/28/21 |
| PROJECT ID | COLUMBIA RD |
| SHEET | TOTAL |
| 17 | 24 |

WORK INSPECTION

THE CONTRACTOR SHALL PROVIDE THE PROJECT ENGINEER AND DISTRICT TRAFFIC ENGINEER WITH 72-HOUR NOTICE OF ANY SIGNAL WORK TO BE PERFORMED AT THE INTERSECTION SITE(S) SO THAT INSPECTION SERVICES CAN BE SUPPLIED.

GUARANTEE

THE CONTRACTOR SHALL GUARANTEE THAT THE TRAFFIC CONTROL SYSTEM INSTALLED AS PART OF THIS CONTRACT SHALL OPERATE SATISFACTORILY FOR A PERIOD OF 90 DAYS FOLLOWING COMPLETION OF THE 10-DAY PERFORMANCE TEST. IN THE EVENT OF UNSATISFACTORY OPERATION, THE CONTRACTOR SHALL CORRECT FAULTY INSTALLATIONS, MAKE REPAIRS AND REPLACE DEFECTIVE PARTS WITH NEW PARTS OF EQUAL OR BETTER QUALITY.

EQUIPMENT, MATERIAL AND LABOR COSTS INCURRED IN CORRECTING AN UNSATISFACTORY OPERATION SHALL BE BORNE BY THE CONTRACTOR.

THE GUARANTEE SHALL COVER THE FOLLOWING ITEMS OF THE TRAFFIC CONTROL SYSTEM: VEHICLE DETECTION EQUIPMENT AND LED LAMP UNITS.

CUSTOMARY MANUFACTURER'S GUARANTEES FOR THE FOREGOING ITEMS SHALL BE TURNED OVER TO THE STATE OR THE MAINTAINING AGENCY FOLLOWING ACCEPTANCE OF THE EQUIPMENT.

THE COST OF GUARANTEEING THE TRAFFIC CONTROL SYSTEM WILL BE INCIDENTAL TO AND INCLUDED IN THE CONTRACT UNIT PRICE OF THE VARIOUS ITEMS MAKING UP THE SYSTEM.

DETECTION MAINTENANCE

IF VEHICLE DETECTION BECOMES UNEXPECTEDLY DISABLED, REQUIRES MODIFICATION, OR IS SCHEDULED TO BE TEMPORARILY REMOVED DURING THE CONSTRUCTION PROJECT, THE CONTRACTOR SHALL IMMEDIATELY NOTIFY THE PROJECT ENGINEER AND DISTRICT TRAFFIC ENGINEER.

IF THE LOSS OF VEHICLE DETECTION IS KNOWN PRIOR TO THE START OF CONSTRUCTION, IT SHALL BE DISCUSSED AT THE PRECONSTRUCTION MEETING. AT SUCH TIME, THE DISTRICT TRAFFIC ENGINEER SHALL ADVISE THE PROJECT ENGINEER AND CONTRACTOR ON THE APPROPRIATE ACTION TO RECTIFY ANY LOSS OF VEHICLE DETECTION. THIS MAY INCLUDE PLACING THE TRAFFIC SIGNAL ON MINIMUM OR MAXIMUM RECALL, MODIFYING THE MINIMUM GREEN TIMES, AND REMOVING THE MALFUNCTIONING DETECTION FROM SERVICE. WHERE NON-INTRUSIVE DETECTION (I.E. VIDEO, RADAR) ALREADY EXISTS, THE CONTRACTOR SHALL INSURE THAT DETECTION IS OPERATING AND MAINTAINED BY RECONFIGURING THE DETECTION UNITS ACCORDINGLY DURING ALL CONSTRUCTION PHASES. THIS IS TO AVOID THE SIGNAL FROM MAXING OUT THE EFFECTED SIGNAL PHASE AND CREATING UNNECESSARY DELAYS.

LOCATIONS WHERE NON-INTRUSIVE DETECTION IS PROPOSED AND THE EXISTING VEHICLE DETECTION IS TO BE ABANDON, THE NON-INTRUSIVE VEHICLE DETECTION SHALL BE INSTALLED, CONFIGURED AND MADE FULLY FUNCTIONAL PRIOR TO THE EXISTING DETECTION BEING DISABLED. THE CONTRACTOR SHALL CONTINUE TO MAINTAIN AND MODIFY THE DETECTION UNTIL FINAL ACCEPTANCE OF THE TRAFFIC SIGNAL. THIS IS TO ENSURE VEHICLE DETECTION REMAINS FULLY FUNCTIONAL THROUGHOUT CONSTRUCTION.

ITEM 809, STOP-LINE RADAR DETECTION, AS PER PLAN

THIS ITEM OF WORK SHALL CONSIST OF FURNISHING AND INSTALLING A WAVETRONIX SMARTSENSOR MATRIX DETECTION UNIT. THE DETECTION UNIT SHALL INCLUDE THE FOLLOWING:

- POWER SHALL BE PROVIDED FROM THE TRAFFIC CABINET.
- ALL REQUIRED INPUTS CARDS SHALL BE INCLUDED IN THE TRAFFIC CABINET AND SHALL BE COMPATIBLE WITH CALTRANS, NEMA TS1 AND NEMA TS2 DETECTOR RACKS. THE CARDS SHALL PROVIDE TRUE PRESENCE DETECTOR CALLS OR CONTACT CLOSURE TO THE TRAFFIC CONTROLLER.
- THE UNIT SHALL BE MOUNTED DIRECTLY TO A POLE OR MAST ARM, AS RECOMMENDED BY THE MANUFACTURER. CABLE(S) SHALL BE PROVIDED AS REQUIRED AND RECOMMENDED BY THE MANUFACTURER.
- SURGE PROTECTION DEVICES, AS RECOMMENDED BY THE MANUFACTURER SHALL BE INCLUDED BOTH AT THE POLE WHERE THE UNIT IS LOCATED TO PROTECT THE UNIT AND IN THE TRAFFIC CABINET TO PROTECT THE CABINET ELECTRONICS.
- THE MANUFACTURER'S REPRESENTATIVE SHALL BE ON SITE DURING INSTALLATION AND TESTING AND SHALL PROVIDE ONSITE TRAINING ON THE SETUP, OPERATION AND MAINTENANCE OF THE UNIT.
- A SERIAL TO ETHERNET COMMUNICATIONS MODULE AND ETHERNET CABLE (MINIMUM 7 FEET).
- THE POWER SUPPLY AND COMMUNICATION MODULES SHALL BE SECURED TO A SINGLE PANEL THAT CAN BE MOUNTED INTERIOR TO THE TRAFFIC CABINET. THE PANEL SHALL INCLUDE MODULAR-PLUG STYLE CONNECTIONS FOR UP TO FOUR (4) SENSOR CABLES. ADDITIONAL SENSORS MAY BE HARD-WIRED TO THE COMMUNICATION MODULES, AS NECESSARY.
- THE CONTRACTOR SHALL INSTALL THE RADAR DETECTION PRIOR TO MILLING/DISABLING EXISTING LOOPS.
- THE INSTALLATION SHALL INCLUDE ALL CONTROLLER PROGRAMMING FOR COMPLETE INSTALLATION, WHICH INCLUDES MODIFICATIONS FOR REMOVAL OF EXISTING DETECTION.

PAYMENT FOR ITEM 809 STOP-LINE RADAR DETECTION, AS PER PLAN SHALL BE MADE AT THE CONTRACT UNIT PRICE FOR EACH UNIT, COMPLETE AND IN PLACE INCLUDING ALL REQUIRED CABINET HARDWARE, MOUNTING BRACKETS, CABLES, CONDUIT AND CONNECTIONS TESTED AND ACCEPTED.

ITEM 632, SIGNALIZATION, MISC.: UNLASH AND RELASH MESSENGER WIRE

THE CONTRACTOR SHALL REMOVE EXISTING MESSENGER WIRE LASHING RODS AND REINSTALL THEM AS NECESSARY FOR THE INSTALLATION OF ANY NEW CABLES ON THE EXISTING INTERSECTION SIGNAL SPANS. THE CABLES SHALL ENTER THE EXISTING STRAIN POLE THROUGH THE POLE CABLE ENTRANCE FITTING AND USE THE EXISTING CONDUIT SYSTEM TO GET TO THE CONTROLLER CABINET. THE NEW CABLES SHALL BE SUPPORTED BY A NEW CABLE SUPPORT ASSEMBLY AT THE TOP OF THE STRAIN POLE.

THE NEW SIGNAL CABLES SHALL BE BID BY SEPARATE BID ITEMS.

PAYMENT FOR ITEM 632 "SIGNALIZATION MISC.: UNLASH AND RELASH MESSENGER WIRE" SHALL BE MADE AT THE CONTRACT UNIT PRICE PER FOOT AND SHALL INCLUDE ALL LABOR, MATERIALS, CABLE SUPPORT ASSEMBLIES AND EQUIPMENT TO INSTALL NEW CABLES ON EXISTING SIGNAL SPAN WIRE INSTALLATIONS.

ITEM 632, REMOVAL OF TRAFFIC SIGNAL INSTALLATION, AS PER PLAN

TRAFFIC SIGNAL INSTALLATIONS, INCLUDING SIGNAL HEADS, CABLE, TRAFFIC PULL BOXES, ETC. SHALL BE REMOVED IN ACCORDANCE WITH C&MS 632.26 AND AS INDICATED ON THE PLANS.

SEE SHEET 19 FOR THE TRAFFIC SIGNAL REMOVAL CHART.

TRAFFIC SIGNALS SUBSUMMARY

| ITEM | QUANTITY | UNIT | ITEM DESCRIPTION | SEE SHEET NUMBER |
|------|----------|------|--|------------------|
| 630 | 1 | EACH | SIGN HANGER ASSEMBLY, SPAN WIRE | |
| 630 | 7.5 | SF | SIGN, FLAT SHEET | |
| 632 | 1 | EACH | VEHICULAR SIGNAL HEAD, (LED), 5-SECTION, 12" LENS, 1-WAY, POLYCARBONATE, BLACK | |
| 632 | 1 | EACH | COVERING OF VEHICULAR SIGNAL HEAD | |
| 632 | 291 | FT | SIGNAL CABLE, 7 CONDUCTOR, NO. 14 AWG | |
| 632 | 1 | EACH | REMOVAL OF TRAFFIC SIGNAL INSTALLATION, AS PER PLAN | 18 |
| 632 | 310 | FT | SIGNALIZATION, MISC.: UNLASH AND RELASH MESSENGER WIRE | 18 |
| 809 | 2 | EACH | STOP-LINE RADAR DETECTION, AS PER PLAN | 18 |

TRAFFIC CONTROL SUBSUMMARY

| REF NO. | SHEET NO. | STATION TO STATION | 621 | 630 | 630 | 630 | 644 | 644 | 644 | 644 | 644 | 644 | 644 |
|-----------------------------------|-----------|----------------------|------|------------------|------------------------------------|---|---------------|-------------|-----------------------|---------------------|------------|-----------|-----------------------------|
| | | | RPM | SIGN. FLAT SHEET | GROUND MOUNTED SUPPORT, NO. 3 POST | REMOVAL OF GROUND MOUNTED SIGN AND DISPOSAL | EDGE LINE, 4" | CENTER LINE | CHANNELIZING LINE, 8" | CROSSWALK LINE, 24" | LANE ARROW | STOP LINE | REMOVAL OF PAVEMENT MARKING |
| | | | EACH | SF | FT | EACH | MILE | MILE | FT | FT | EACH | FT | FT |
| EL1 | 17 | 3+95.00 TO 9+82.26 | | | | | 0.11 | | | | | | |
| EL2 | 17 | 3+95.00 TO 9+17.55 | | | | | 0.10 | | | | | | |
| DY1 | 17 | 5+42.41 TO 9+18.40 | 6 | | | | | 0.07 | | | | | |
| DY2 | 17 | 4+14.00 TO 7+33.71 | 6 | | | | | 0.06 | | | | | |
| CH1 | 17 | 6+41.02 TO 9+27.81 | 8 | | | | | | 287 | | | | |
| CH2 | 17 | 7+50.00 TO 9+27.81 | 6 | | | | | | 178 | | | | |
| CH3 | 17 | 4+14.08 TO 5+40.85 | 4 | | | | | | 127 | | | | |
| CW1 | 17 | 9+06.80 TO 9+65.41 | | | | | | | | 397 | | | |
| CW2 | 17 | 9+65.29 TO 10+81.53 | | | | | | | | 218 | | | 310 |
| LA1 | 17 | 4+41.58 | | | | | | | | | 1 | | |
| LA2 | 17 | 4+83.60 | | | | | | | | | 1 | | |
| LA3 | 17 | 6+34.13 | | | | | | | | | 1 | | |
| LA4 | 17 | 6+49.22 | | | | | | | | | 1 | | |
| LA5 | 17 | 7+78.39 | | | | | | | | | 1 | | |
| LA6 | 17 | 7+83.79 | | | | | | | | | 1 | | |
| LA7 | 17 | 8+44.39 | | | | | | | | | 1 | | |
| LA8 | 17 | 8+49.79 | | | | | | | | | 1 | | |
| LA9 | 17 | 9+10.39 | | | | | | | | | 1 | | |
| LA10 | 17 | 9+15.79 | | | | | | | | | 1 | | |
| SL1 | 17 | 9+18.40 TO 9+20.40 | | | | | | | | | | | 11.5 |
| SL2 | 17 | 9+25.81 TO 9+27.81 | | | | | | | | | | | 23.5 |
| SL3 | 17 | 10+32.05 TO 10+77.22 | | | | | | | | | | | 47.5 |
| SN2 | 17 | 5+65.00 | | | | | | | | | | | |
| SN3 | 17 | 7+40.00 | | 10.0 | 15.5 | | | | | | | | |
| SN4 | 17 | 8+03.00 | | | | | 1 | | | | | | |
| SN5 | 17 | 8+06.00 | | | | | 1 | | | | | | |
| SN6 | 17 | 9+36.00 | | 9.0 | 14.5 | 1 | | | | | | | |
| TOTALS CARRIED TO GENERAL SUMMARY | | | 30 | 19.0 | 30.0 | 4 | 0.21 | 0.13 | 592 | 615 | 10 | 83 | 360 |

DESIGN AGENCY

 DESIGNER
 NRB
 REVIEWER
 NAU 06/28/21
 PROJECT ID
 COLUMBIA RD
 SHEET TOTAL
 18 24

NOTES:
 1. ALL STATIONING AND OFFSETS BASED OFF @ CONSTRUCTION COLUMBIA ROAD
 2. PROPOSED FIVE-SECTION SIGNAL HEAD SHALL BE ALIGNED WITH THE NORTHBOUND CHANNELIZING LINE SEPARATING THE THROUGH LANE AND RIGHT TURN LANE.

ITEM 632 - REMOVAL OF TRAFFIC SIGNAL INSTALLATION, AS PER PLAN

| QUANTITY | REMOVED ITEM DESCRIPTION | DISPOSED OF BY CONTRACTOR | STORED FOR PICK UP |
|----------|--------------------------|---------------------------|--------------------|
| LUMP | SIGNAL CABLE | X | |
| 1 | VEHICULAR SIGNAL HEADS | X | |
| 2 | TRAFFIC PULL BOXES | X | |
| | | | |

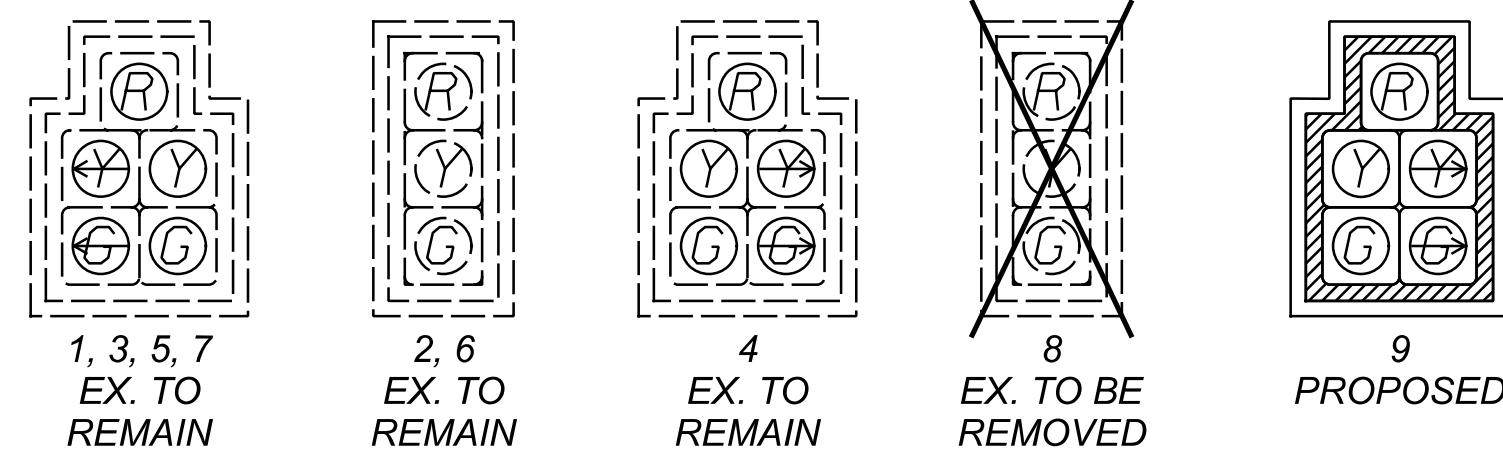
VEHICULAR SIGNAL HEADS
 12" LED LENSES W/ BACKPLATES



EXISTING SIGNS

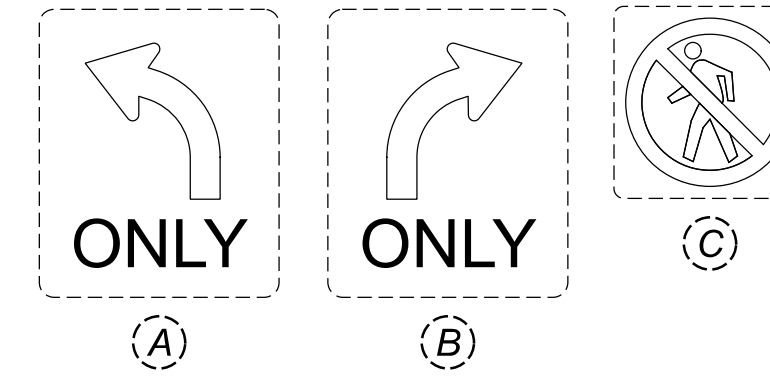

PROPOSED SIGNS

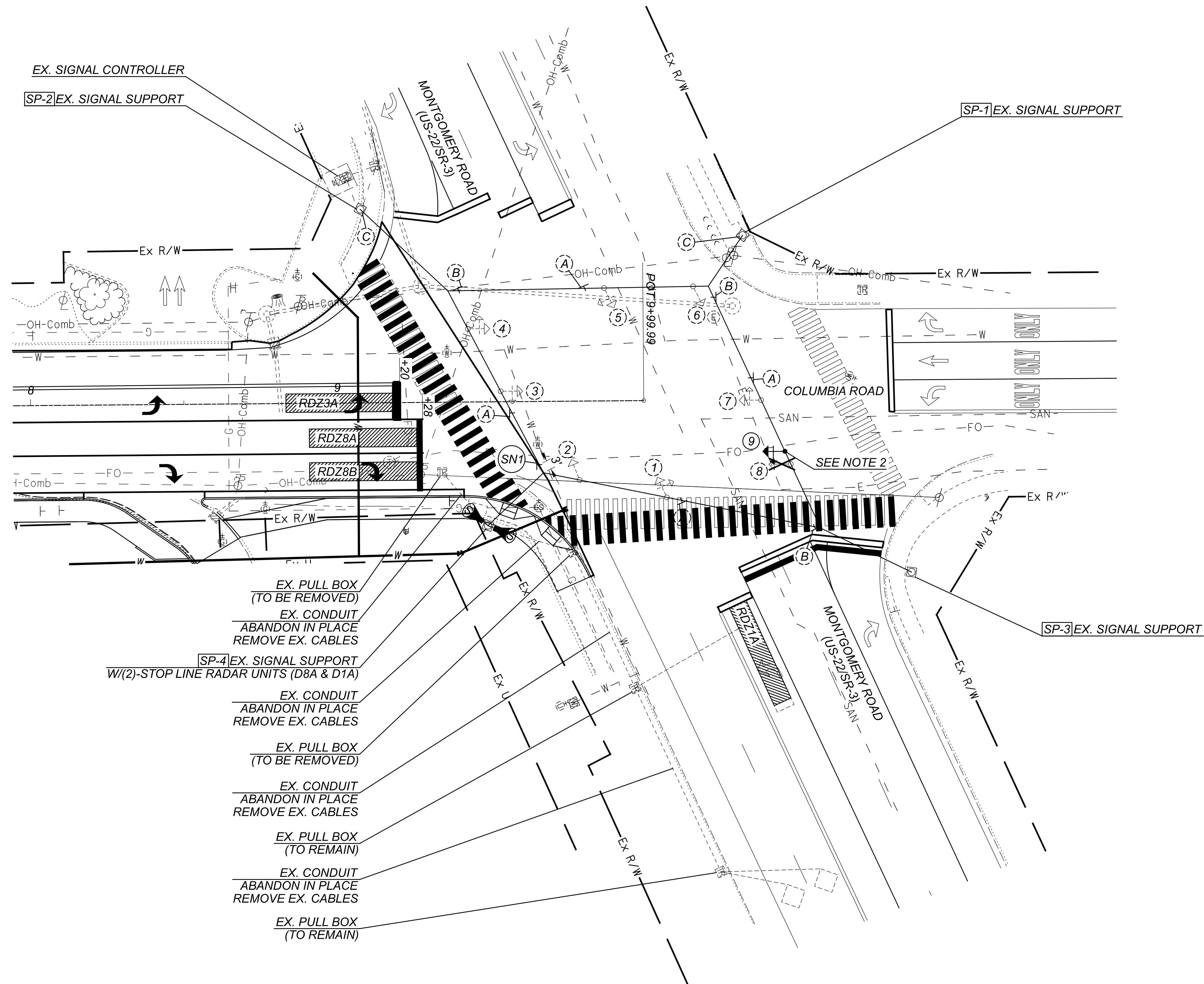
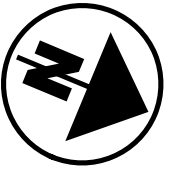
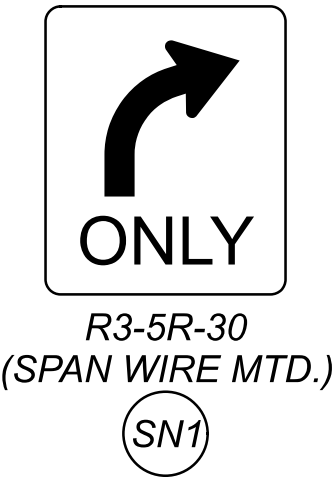

LEGEND

| | EX. | PROP. |
|----------------------------------|-----|-------|
| TRAFFIC SIGNAL, 3 UNIT HEAD, 12" | | |
| TRAFFIC SIGNAL, 5 UNIT HEAD, 12" | | |
| SIGNAL SUPPORT POLE | | |
| CONTROLLER CABINET AND WORK PAD | | |
| TRAFFIC PULL BOX | | |

TRAFFIC SIGNAL MODIFICATION PLAN
 COLUMBIA ROAD & MONTGOMERY ROAD (US-22/SR-3)

DESIGN AGENCY



DESIGNER

NRB

REVIEWER

NAU 06/28/21

PROJECT ID

COLUMBIA RD

SHEET TOTAL

19 24

SIGNAL TIMING CHART

| INTERSECTION: COLUMBIA ROAD & MONTGOMERY ROAD (US-22/SR-3) MAINTAINING AGENCY: OHIO DEPARTMENT OF TRANSPORTATION | | | | | | | | |
|---|-------------------------|-----------------|------|-------------|------|--------|------|-----|
| START UP | | DUAL ENTRY: EX. | | PHASES: EX. | | | | |
| START IN: | EX. | REST IN RED: | | RING 1 | EX. | RING 2 | EX. | EX. |
| TIME FOR FLASH, ALL RED: | EX. | OVERLAP | | A | B | C | D | |
| FIRST PHASE(S): | EX. | PHASES | | Ø1 | Ø5 | - | - | |
| COLOR DISPLAYED: | EX. | | | | | | | |
| INTERVAL OR FEATURE | CONTROLLER MOVEMENT NO. | | | | | | | |
| INTERSECTION MOVEMENT (PHASE) | 1 | 2 | 3 | 4 | 5 | 6 | 7 | 8 |
| DIRECTION | WBLT | EB | NBLT | SB | EBLT | WB | SBLT | NB |
| MINIMUM GREEN (INITIAL) (SEC.) | EX. | EX. | EX. | EX. | EX. | EX. | EX. | EX. |
| ADDED INITIAL *(SEC./ACTUATION) | EX. | EX. | EX. | EX. | EX. | EX. | EX. | EX. |
| MAXIMUM INITIAL (SEC.) | EX. | EX. | EX. | EX. | EX. | EX. | EX. | EX. |
| PASSAGE TIME (PRESET GAP) (SEC.) | EX. | EX. | EX. | EX. | EX. | EX. | EX. | EX. |
| TIME BEFORE REDUCTION *(SEC.) | EX. | EX. | EX. | EX. | EX. | EX. | EX. | EX. |
| MINIMUM GAP *(SEC.) | EX. | EX. | EX. | EX. | EX. | EX. | EX. | EX. |
| TIME TO REDUCE *(SEC.) | EX. | EX. | EX. | EX. | EX. | EX. | EX. | EX. |
| MAXIMUM GREEN I (SEC.) | EX. | EX. | EX. | EX. | EX. | EX. | EX. | EX. |
| MAXIMUM GREEN II (SEC.) | EX. | EX. | EX. | EX. | EX. | EX. | EX. | EX. |
| YELLOW CHANGE (SEC.) | EX. | EX. | EX. | EX. | EX. | EX. | EX. | EX. |
| ALL RED CLEARANCE (SEC.) | EX. | EX. | EX. | EX. | EX. | EX. | EX. | EX. |
| DELAYED GREEN (LPI) # (SEC.) | EX. | EX. | EX. | EX. | EX. | EX. | EX. | EX. |
| WALK (SEC.) | EX. | 7 | EX. | 14 | EX. | 7 | EX. | EX. |
| FLASHING YELLOW ARROW DELAY # | EX. | EX. | EX. | EX. | EX. | EX. | EX. | EX. |
| PEDESTRIAN CLEARANCE (SEC.) | EX. | 21 | EX. | 29 | EX. | 17 | EX. | EX. |
| RECALL | MAXIMUM (ON/OFF) | EX. | EX. | EX. | EX. | EX. | EX. | EX. |
| | MINIMUM (ON/OFF) | EX. | EX. | EX. | EX. | EX. | EX. | EX. |
| | PEDESTRIAN (ON/OFF) | EX. | EX. | EX. | EX. | EX. | EX. | EX. |
| MEMORY (ON/OFF) | EX. | EX. | EX. | EX. | EX. | EX. | EX. | EX. |

PHASING DIAGRAM

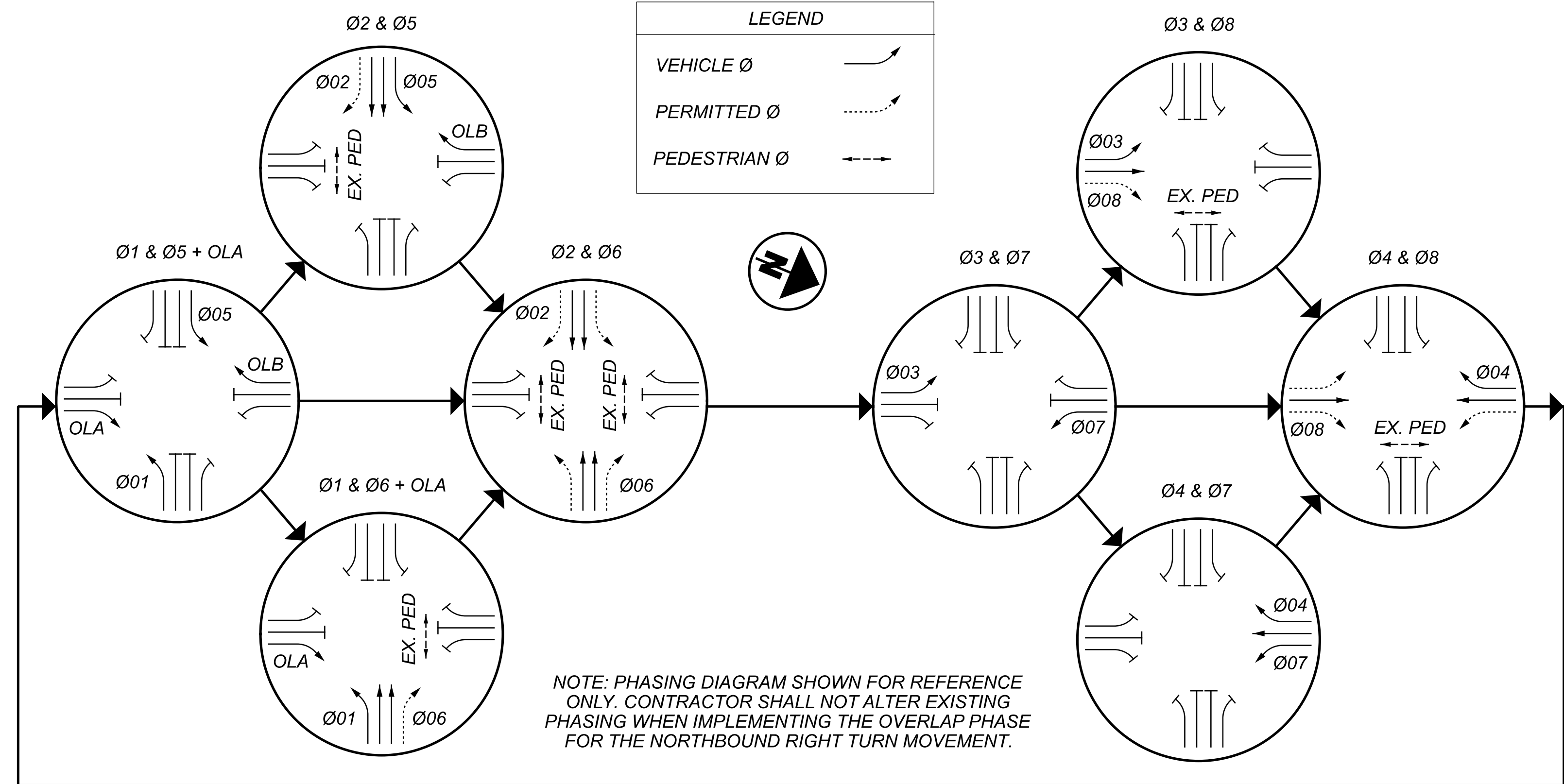

RADAR DETECTION CHART

| DETECTION ZONE | MOVEMENT | WIDTH | DELAY PROGRAMMED IN CONTROLLER (SEC.) | EXTENSION PROGRAMMED IN CONTROLLER (SEC.) | DETECTOR NUMBER | PURPOSE | DETECTION ZONE LENGTH |
|----------------|----------|-------|---------------------------------------|---|-----------------|-----------|-----------------------|
| RDZ1A | WBLT | 6' | - | - | D1A | STOP LINE | 35' |
| RDZ3A | NBLT | 6' | - | - | D8A | STOP LINE | 35' |
| RDZ8A | NB | 6' | - | - | D8A | STOP LINE | 35' |
| RDZ8B | NBRT | 6' | 12 | - | D8A | STOP LINE | 35' |

FIELD WIRING HOOK-UP CHART

| SIGNAL HEAD | INDICATION | FIELD TERMINAL | FLASH |
|-------------|------------|----------------|-------|
| 9 NBRT | R | Ø8 R | R |
| | Y | Ø8 Y | |
| | G | Ø8 G | |
| | -Y> | Ø1 Y | |
| | -G> | Ø1 R | |

LS = LOAD SWITCH OLA = LS 13

WIRING DIAGRAM (NOT TO SCALE)

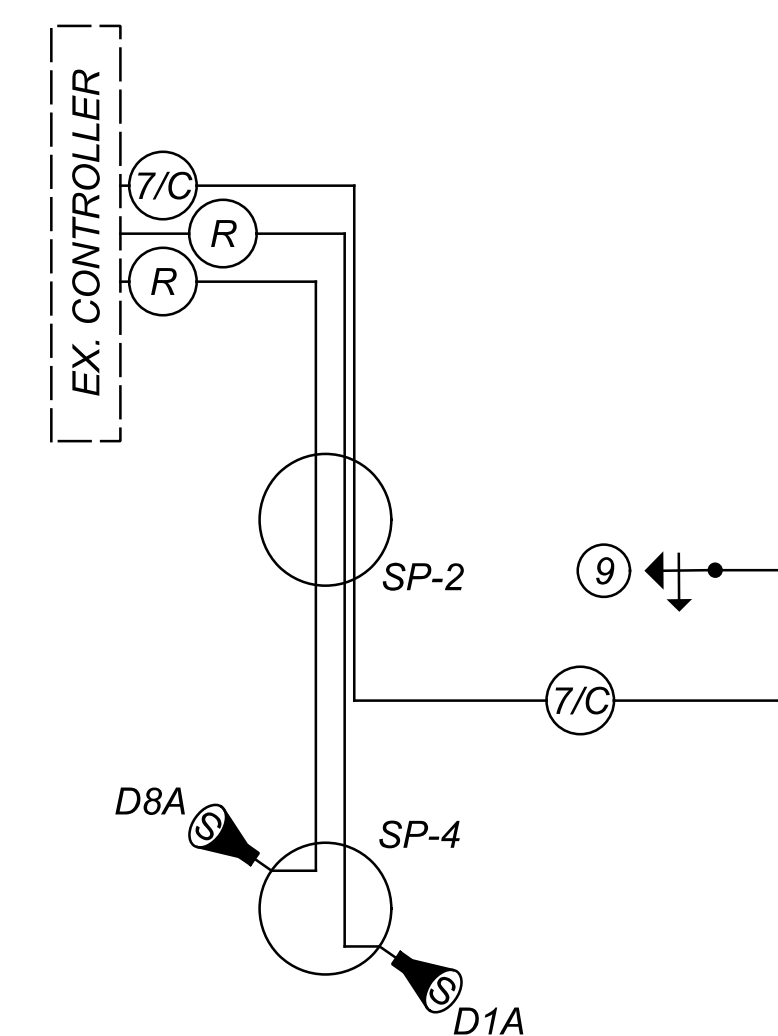

WATER WORK NOTES

1. ALL WATER MAINS SHALL HAVE A MINIMUM COVER OF 4'-6"
 A. ALL WATER SERVICE LATERALS SHALL HAVE MINIMUM COVER OF 42"
2. ALL WATER MAINS SHALL BE DUCTILE IRON CONFORMING WITH AWWA SPEC. C-151 CLASS 52 IN SIZES 4"-16" AND PSI CLASS 350 FOR 20" AND ABOVE.
3. COMPACT FITTINGS ARE PERMITTED.
4. ALL WATER VALVES MUST OPEN LEFT. ALL VALVE BOX LIDS MUST BE CAST/STAMPED "WCWD" IN 1 1/2" LETTERS AND BE NEENAH-NF-19130002 OR EQUAL. ALL VALVE EXTENSIONS TO HAVE SET SCREWS.
5. A CONCRETE SLAB MUST BE PROVIDED AT FINAL GRADE AROUND ALL MAIN VALVE BOXES. THE SLABS MUST BE EIGHTEEN INCHES (18") SQUARE/CIRCLE AND NINE INCHES (9") THICK. PREFABRICATED CONCRETE RINGS ARE ACCEPTABLE
6. WATER AND SEWER LINES SHALL HAVE A MINIMUM OF TEN FEET (10') HORIZONTAL SEPARATION AND/OR TWO FEET (2') VERTICAL SEPARATION.
7. NO GATE VALVE, METER PIT, BLOW OFF OR CORPORATION STOP SHALL BE LOCATED UNDER OF WITHIN THREE FEET (3') OF DRIVEWAYS, ROADWAYS OR SIDEWALK.
8. NO DRIVEWAY SHALL BE INSTALLED WITHIN FIVE FEET (5') OF A FIRE HYDRANT.
9. A MINIMUM OF THREE FEET (3') IS REQUIRED BETWEEN CORPORATION STOPS. NO TAP SHALL BE MADE WITHIN THREE (3') OF A BELL.
10. THE LOCATION OF WATER SERVICE LATERALS MUST BE STAMPED IN THE CURB AT THE TIME THE CURB IS PLACED TO PERMANENTLY INDICATE THE LOCATION OF SAID LATERALS.
11. THE LOCATION OF ALL WATER SERVICE LATERALS BENDS, TEE, ETC. MUST BE PROVIDED ON THE AS-BUILT PLANS. ALL OF THESE APPURTENANCES SHOULD BE SURVEYED IN STATE PLANE COORDINATES AND ELECTRONICALLY DELIVERED TO THE OWNER.
12. CONTRACTOR SHALL SUBMIT AS-BUILT PLANS OF SANITARY AND WATER LATERALS TO THE OWNER.
13. ALL WATER MAINS CROSSING UNDER STORM DRAINS SHALL BE BACKFILLED WITH GRANULAR MATERIAL, ODOT ITEM 310.02. BETWEEN MAINS AND DRAINS.
14. EACH SERVICE LATERAL MUST BE A CONTINUOUS PIECE OF PIPE FROM THE CORP STOP TO THE METER. COUPLINGS SHALL NOT BE ALLOWED. TYPE K COPPER SHALL BE USED FOR 3/4" AND 1" SERVICES. POLYETHYLENE 200 PSI (COPPER TUBE SIZE) MAY BE USED FOR 1 1/2" AND 2" SERVICES. TRACER WIRE MUST BE USED WITH POLY AND SDR 21.

WATER WORK NOTES (CONTINUED)

15. SERVICE LINES 1" AND LARGER MUST BE EITHER TYPE K COPPER, PLY 200 PSI OR SDR 21. TRACER WIRE MUST BE TAPED EVENLY EVERY 3' ON POLY AND SDR 21 FROM THE METER PIT INTO THE STRUCTURE BEING SERVED (A 3' LEAD IS REQUIRED INTO THE PIT).
16. 1 1/2" AND 2" SERVICE LINES FROM THE CORP STOP TO THE METER PIT MUST BE TYPE K COPPER OR POLYETHYLENE 200 PSI. POLY MUST HAVE A TRACER WIRE.
17. SWAB PIPE WITH 50 PPM CHLORINE SOLUTION BE INSTALLATION.
18. ALL NEW WATER MAINS SHALL BE PRESSURE TESTED FOR 2 HOURS AT 200 PSI, WHICHEVER IS GREATER. ALLOWABLE LEAKAGE SHALL BE PER TABLE 6A OF AWWA C-600.
19. DEDUCT METERS SHALL NOT BE ALLOWED.
20. NO IRRIGATION CONNECTIONS SHALL BE ALLOWED IN THE METER PIT.
21. BACK FLOW PREVENTER THAT COMPLIES WITH A.S.S.E. 1013 IS TO BE INSTALLED AHEAD OF ANY SPRINKLER BUT NOT IN THE METER PIT.
22. ALL MATERIALS USED SHALL BE DOMESTIC, MADE IN THE UNITED STATES OF AMERICA.
23. ALL WATER LINES TO BE ABANDONED SHALL BE PLUGGED PER WARREN COUNTY WATER AND SERWER STANDARDS AND REGULATIONS

| SHEET NO. | STATION TO STATION | 202 | 638 | 638 | 638 | 638 | 638 | 638 | 638 |
|-----------|--------------------|---------------------|--|----------------------------|--------------------------|----------------------------------|---------------|--|-----|
| | | METER VAULT REMOVED | 8" WATER MAIN DUCTILE IRON PIPE ANSI CLASS 52, PUSH-ON JOINTS AND FITTINGS | 3/4" COPPER SERVICE BRANCH | 1" COPPER SERVICE BRANCH | METER, SETTING, STOP AND CHAMBER | 8" GATE VALVE | 12" X 8" TAPPING SLEEVE, VALVE AND VALVE BOX | 638 |
| | | EACH | FT | FT | FT | EACH | EACH | EACH | FT |
| 22-23 | 3+83.47 TO 9+06.94 | 3 | 628 | 138 | 80 | 3 | 2 | 1 | 520 |

**WATER WORK
GENERAL NOTES**

DESIGN AGENCY

DESIGNER
WCS

REVIEWER
BAA 01-20-22

PROJECT ID
COLUMBIA RD

| | |
|-------|-------|
| SHEET | TOTAL |
| 21 | 24 |

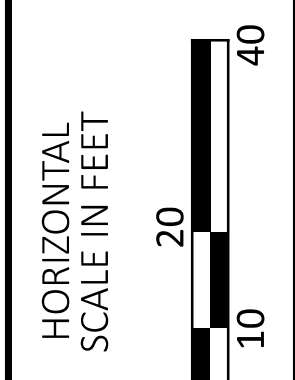
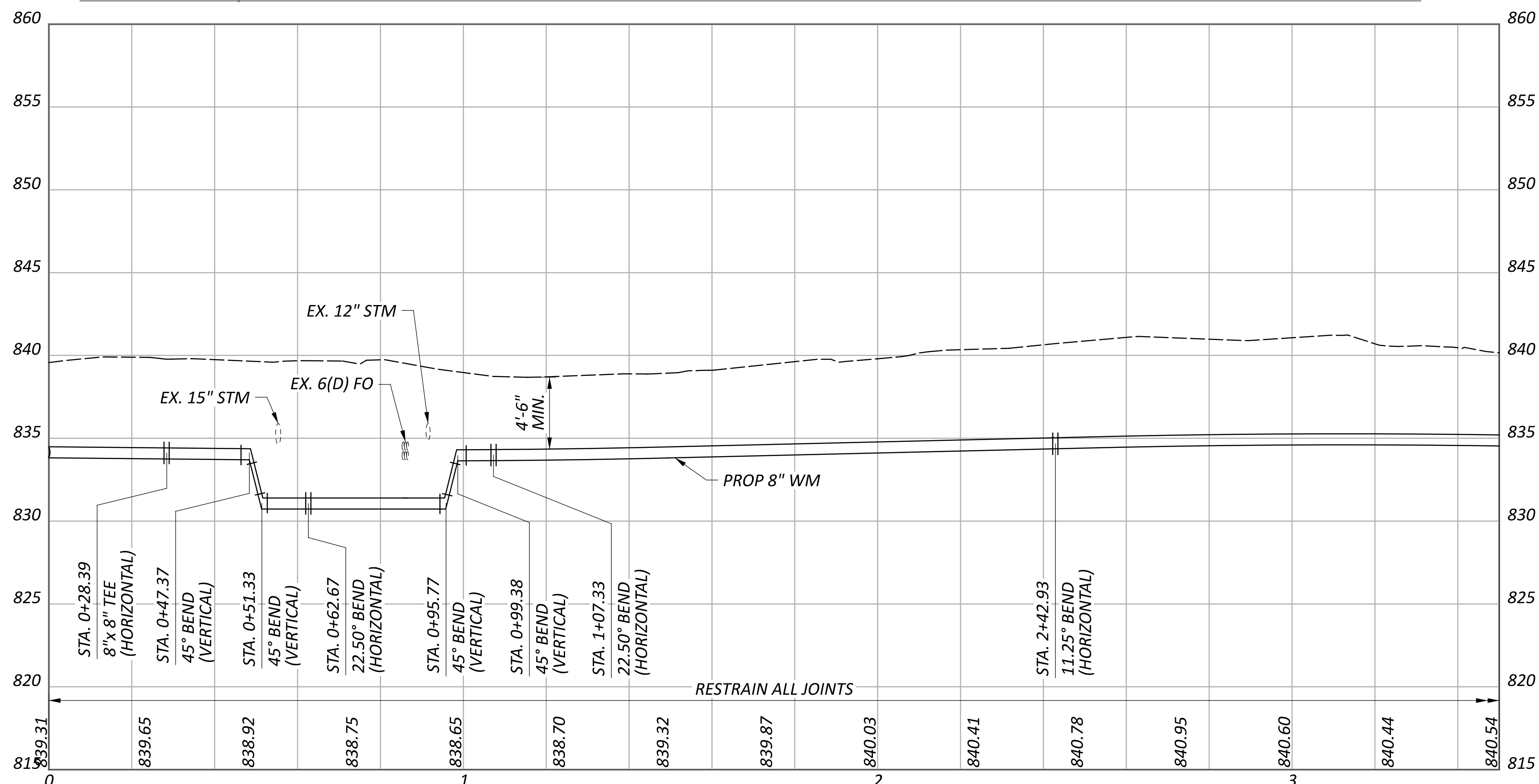
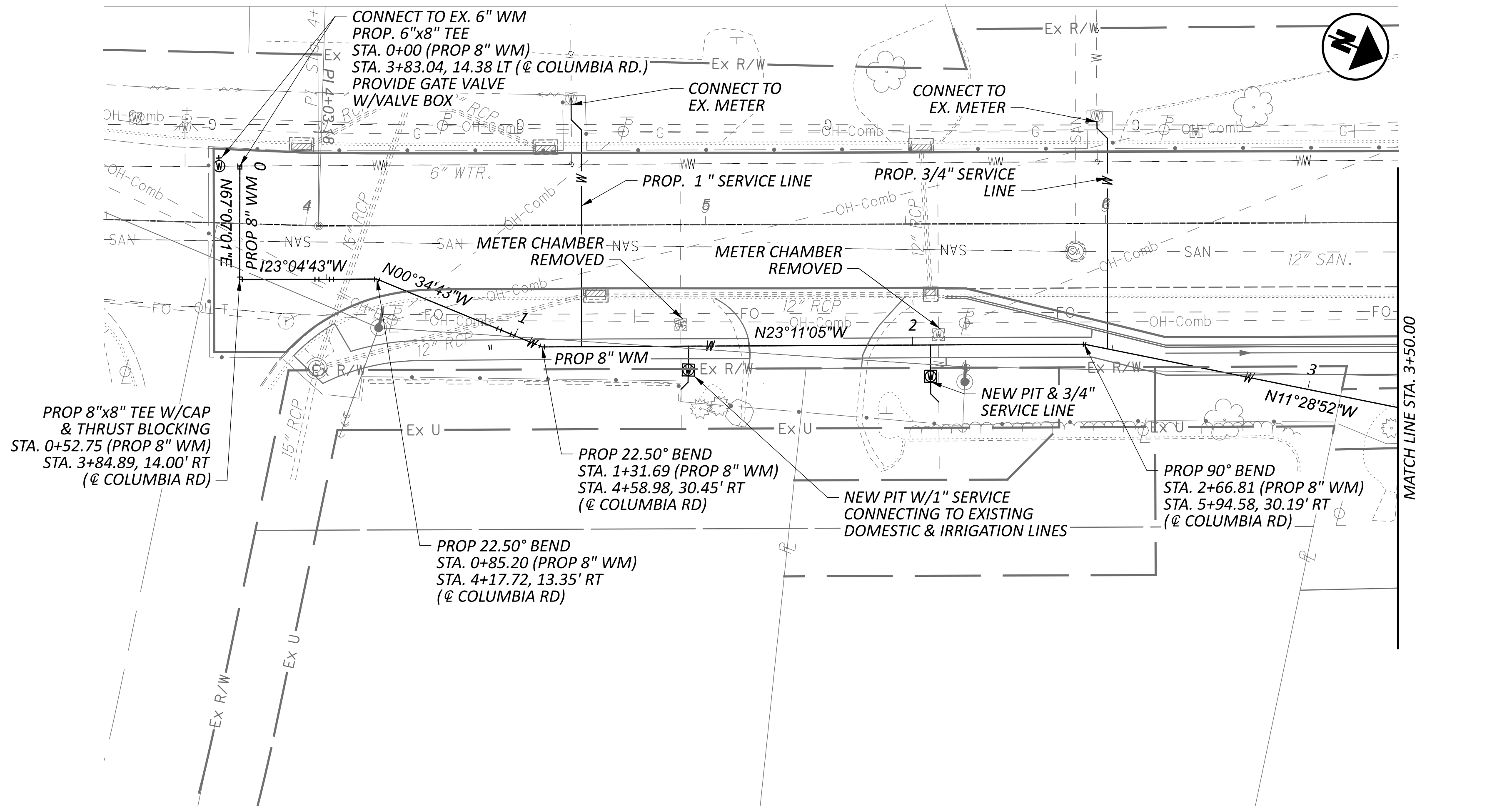

WATER WORK - PLAN AND PROFILE
 STA. 0+00.00 TO STA. 3+50.00

| | |
|--------------------|----------|
| DESIGN AGENCY | |
| CARPENTER MARTY | |
| DESIGNER | WCS |
| REVIEWER | BAA |
| PROJECT ID | 01/04/22 |
| COLUMBIA RD | |
| SHEET | TOTAL |
| 22 | 24 |

COLUMBIA RD.

MODEL: Columbia - WaterWork02 PAPER SIZE: 34x22 (in.) DATE: 2/22/2022 TIME: 3:41:47 PM USER: backel
 P:\WAR\TR\0002\Columbia Rd\400-Engineering\Utilities\Sheets\Columbia - WaterWork02.dgn

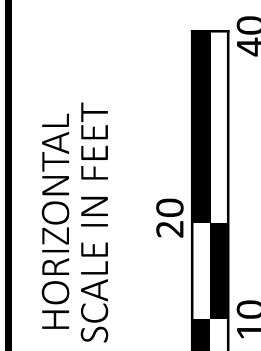
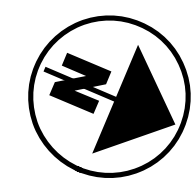
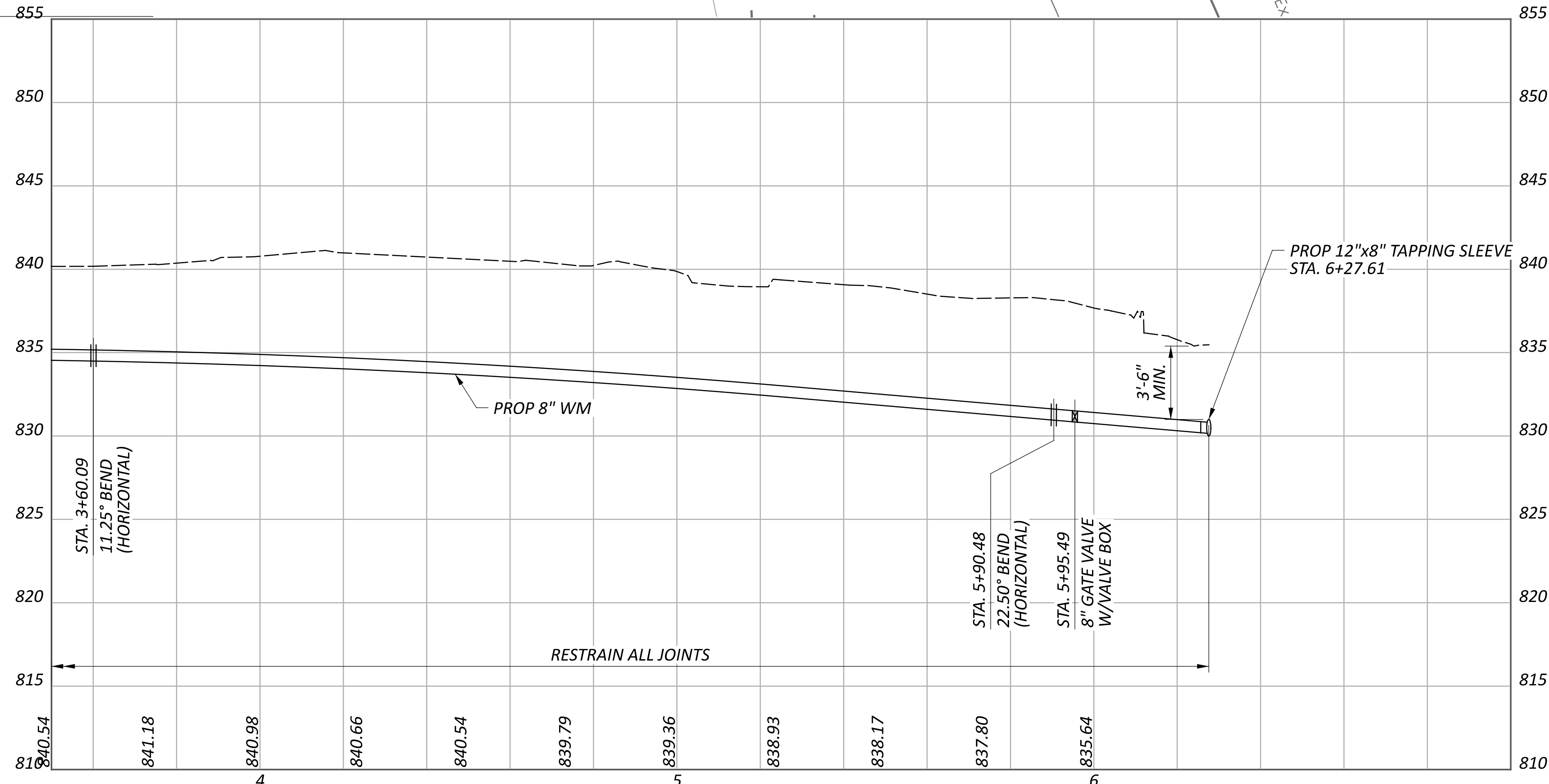
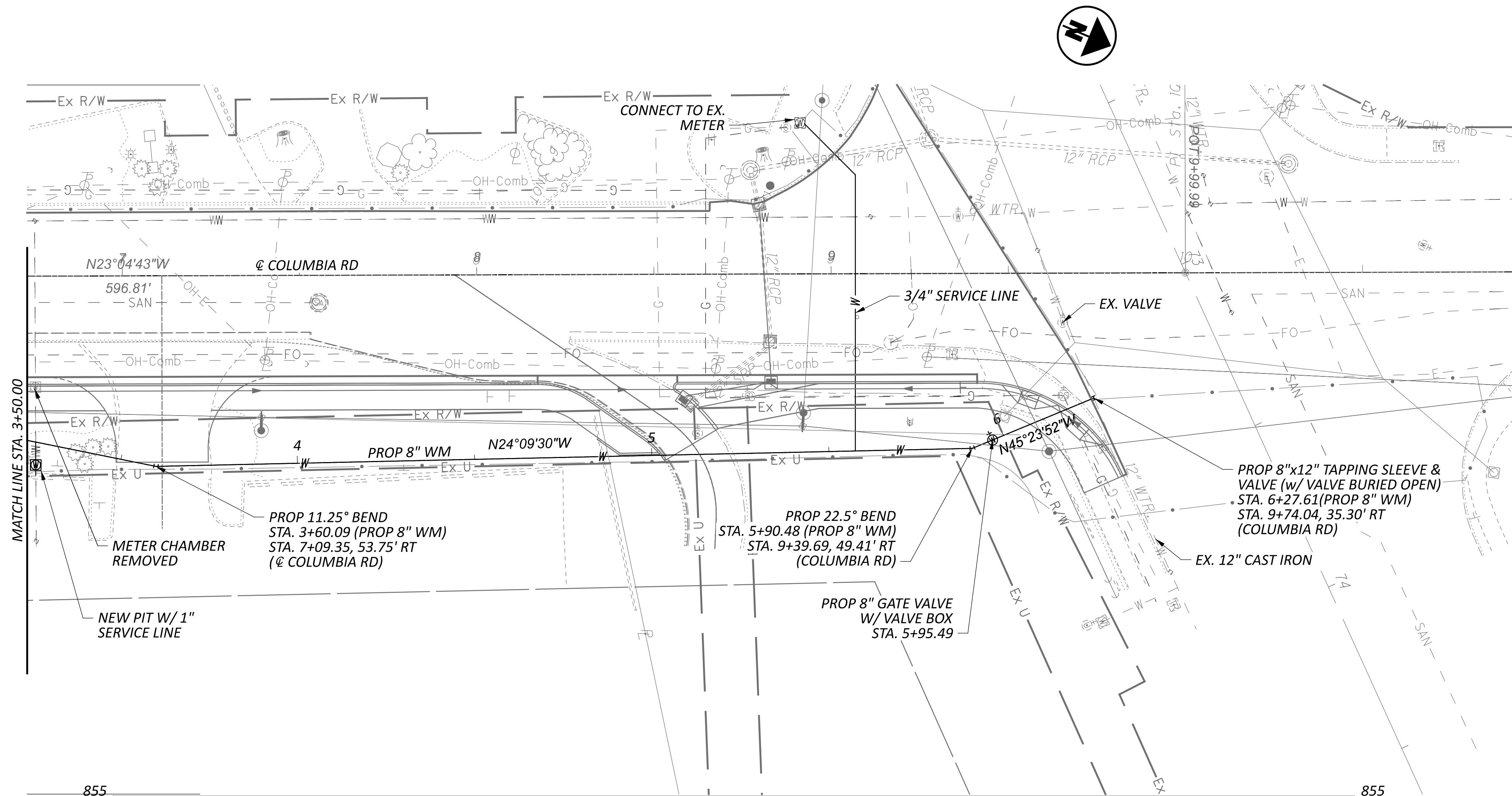

**WATER WORK - PLAN AND PROFILE
 STA. 3+50.00 TO STA. 5+00.00**

DESIGN AGENCY



DESIGNER
WCS

REVIEWER
BAA 01/04/22

PROJECT ID
COLUMBIA RD

SHEET TOTAL
 23 24

THRUST BLOCK DETAILS

| | | |
|--------------------------------|---|-------------------------------|
| APPROVED/REVISED JUNE, 2012 | WARREN COUNTY STANDARD DETAILS DEPARTMENT OF WATER & SEWER | STANDARD NUMBER W-3 |
|--------------------------------|---|-------------------------------|

ANCHORS & BUTTRESSES FOR VERTICAL BENDS

| | | |
|---------------------------------|---|--------------------------------|
| APPROVED/REVISED MARCH, 2018 | WARREN COUNTY STANDARD DETAILS DEPARTMENT OF WATER & SEWER | STANDARD NUMBER W-17 |
|---------------------------------|---|--------------------------------|

METER BOX DETAIL FOR 3/4" AND 1" METERS

| | | |
|---------------------------------|---|---------------------------------|
| APPROVED/REVISED MARCH, 2018 | WARREN COUNTY STANDARD DETAILS DEPARTMENT OF WATER & SEWER | STANDARD NUMBER W-10A |
|---------------------------------|---|---------------------------------|

MINIMUM 54' OF RESTRAINED JOINT PIPE (RJP) IS REQUIRED BEFORE AND AFTER ALL BENDS. REFER TO TABLE BELOW.

RESTRAINT OPTIONS:
 MECHANICAL JOINT W/ MEGALUGS ~ ALL SIZES OF PIPE
 MJ FIELD LOCKS ~ < 24" PIPE

| d | 4" | 6" | 8" | 10" | 12" | 16" | 20" | 24" |
|---|-----|-----|-----|-----|-----|-----|------|------|
| l | 54' | 54' | 54' | 54' | 66' | 98' | 125' | 145' |

REQUIRED RESTRAINED JOINTS FOR BENDS

| | | |
|---------------------------------|---|--------------------------------|
| APPROVED/REVISED MARCH, 2018 | WARREN COUNTY STANDARD DETAILS DEPARTMENT OF WATER & SEWER | STANDARD NUMBER W-18 |
|---------------------------------|---|--------------------------------|

MINIMUM 54' OF RESTRAINED JOINT PIPE (RJP) IS REQUIRED BEFORE AND AFTER ALL BENDS. REFER TO TABLE BELOW.

| d | 4" | 6" | 8" | 10" | 12" | 16" | 20" | 24" |
|---|-----|-----|-----|-----|-----|-----|------|------|
| l | 54' | 54' | 54' | 54' | 66' | 98' | 125' | 145' |

REQUIRED RESTRAINED JOINTS - DEAD END VALVES, PLUGS, CAPS & TEES

| | | |
|---------------------------------|---|--------------------------------|
| APPROVED/REVISED MARCH, 2018 | WARREN COUNTY STANDARD DETAILS DEPARTMENT OF WATER & SEWER | STANDARD NUMBER W-19 |
|---------------------------------|---|--------------------------------|

ALL DIMENSIONS ARE MINIMUM - ACTUAL TO BE PER COUNTY ENGINEER OR ODOT INSTRUCTIONS & PERMIT.

TRAFFIC MUST BE MAINTAINED AT ALL TIMES; LIGHTS, SIGNS, BARRICADES AND IF NECESSARY, FLAGMAN AND WATCHMEN TO BE ON JOB FOR PROTECTION OF THE PUBLIC. STREET PLATES MUST CONFORM TO COUNTY ENGINEER OR ODOT REQUIREMENTS.

FLASHFILL OR CONTROLLED DENSITY FILL TO A MINIMUM DISTANCE OF 5 FEET BEYOND THE EDGE OF PAVEMENT. TRENCH BACKFILL AND PAVEMENT RESTORATION MUST CONFORM TO THE APPLICABLE WARREN COUNTY ENGINEER OR ODOT SPECIFICATIONS.

EXISTING PAVEMENT EDGES SHALL BE NEATLY AND SQUARELY TRIMMED AND/OR MILLED. PAVEMENT MUST MATCH EXISTING ROAD THICKNESS OR AS SPECIFIED BY COUNTY ENGINEER OR ODOT.

ROAD PAVEMENT CUT AND RESTORATION AT ROADWAY CROSSING

| | | |
|---------------------------------|---|--------------------------------|
| APPROVED/REVISED MARCH, 2018 | WARREN COUNTY STANDARD DETAILS DEPARTMENT OF WATER & SEWER | STANDARD NUMBER W-20 |
|---------------------------------|---|--------------------------------|

***BID/CONTRACT DOCUMENTS
COLUMBIA ROAD TURN LANE PROJECT
ON BEHALF OF
NEIL F. TUNISON
WARREN COUNTY ENGINEER***

**WARREN COUNTY BOARD OF COMMISSIONERS
406 JUSTICE DRIVE
LEBANON, OHIO 45036
(513) 695-1250**

PROPOSAL PRICE (BID) SHEET

**COLUMBIA ROAD TURN LANE PROJECT
BID PROPOSAL**

| Reference No. | Item No. | Description | Quantity | Unit | Unit Cost | Total Cost |
|---------------|----------|--|----------|------|-------------|-------------|
| | | ROADWAY | | | | |
| 1 | 202 | Pavement Removed | 321 | SY | | |
| 2 | 202 | Walk Removed | 459 | SF | | |
| 3 | 202 | Curb and Gutter Removed | 540 | FT | | |
| 4 | 202 | Pipe Removed, 24" and Under | 64 | FT | | |
| 5 | 202 | Catch Basin Removed | 2 | EACH | | |
| 6 | 202 | Removal Mics.: Landscape Wall Removed | 42 | FT | | |
| 7 | 203 | Excavation | 449 | CY | | |
| 8 | 203 | Embankment | 67 | CY | | |
| 9 | 204 | Subgrade Compaction | 670 | SY | | |
| 10 | 608 | 5" Concrete Walk | 3,455 | SF | | |
| 11 | 608 | Curb Ramp | 120 | SF | | |
| 12 | Special | Undercutting Subgrade | 350 | CY | | |
| 13 | Special | Granular Repair of Subgrade | 350 | CY | | |
| | | | | | Sub-Total = | |
| | | EROSION CONTROL | | | | |
| 14 | 659 | Topsail | 37 | CY | | |
| 15 | 659 | Seeding and Mulching | 489 | SY | | |
| 16 | 659 | Commercial Fertilizer | 0.05 | TON | | |
| 17 | 659 | Water | 1 | MGAL | | |
| 18 | 832 | Erosion Control | 1 | EACH | \$ 1,000.00 | \$ 1,000.00 |
| | | | | | Sub-Total = | |
| | | DRAINAGE | | | | |
| 19 | 605 | 4" Shallow Pipe Underdrains | 354 | FT | | |
| 20 | 611 | 4" Conduit, Type F for Underdrain Outlet | 20 | FT | | |
| 21 | 611 | 12" Conduit, Type B, 706.02 or 707.65 | 48 | FT | | |
| 22 | 611 | 12" Conduit, Type C, 706.02 or 707.65 | 23 | FT | | |
| 23 | 611 | Catch Basin, No. 3A | 2 | EACH | | |
| 24 | 611 | Manhole Adjusted to Grade | 4 | EACH | | |
| | | | | | Sub-Total = | |
| | | PAVEMENT | | | | |
| 25 | 252 | Full Depth Rigid Pavement Removal and Flexible Replacement | 227 | SY | | |
| 26 | 254 | Pavement Planing, Asphalt Concrete (1-1/2" Depth) | 2,266 | SY | | |
| 27 | 302 | Asphalt Concrete Base, PG64-22 | 174 | TON | | |
| 28 | 304 | Aggregate Base | 112 | CY | | |
| 29 | 407 | Tack Coat | 228 | GAL | | |
| 30 | 441 | Asphalt Concrete Surface Course, Type 1, (448), PG 64+22 | 242 | TON | | |
| 31 | 441 | Asphalt Concrete Intermediate Course, Type 2, (448) | 62 | TON | | |
| 32 | 609 | Combination Curb and Gutter, Type 2 | 328 | FT | | |
| 33 | 609 | Curb, Type 6 | 179 | FT | | |
| | | | | | Sub-Total = | |

**COLUMBIA ROAD TURN LANE PROJECT
BID PROPOSAL**

| Reference No. | Item No. | Description | Quantity | Unit | Unit Cost | Total Cost |
|---------------|----------|--|----------|------|-------------|------------|
| | | WATER WORK | | | | |
| 34 | 638 | 8" Watermain Ductile Iron Pipe ANSI Class 52, Push-On Joints and Fittings | 628 | FT | | |
| 35 | 638 | 3/4" Copper Service Branch | 138 | FT | | |
| 36 | 639 | 1" Copper Service Branch | 80 | FT | | |
| 37 | 638 | 8" Gate Valve | 2 | EACH | | |
| 38 | 638 | 12"x8" Tapping Sleeve, Valve and Valve Box | 1 | EACH | | |
| 39 | 638 | Meter Vault Removed | 3 | EACH | | |
| 40 | 638 | Meter, Setting, Stop and Chamber | 3 | EACH | | |
| 41 | 638 | Water Work, Misc.: Plug and Abandon in Place | 520 | FT | | |
| | | | | | Sub-Total = | |
| | | TRAFFIC CONTROL | | | | |
| 42 | 621 | RPM | 30 | EACH | | |
| 43 | 621 | Raised Pavement Marker Removed | 16 | EACH | | |
| 44 | 630 | Ground Mounted Support, No. 3 Post | 30 | FT | | |
| 45 | 630 | Removal of Ground Mounted Sign and Disposal | 4 | EACH | | |
| 46 | 630 | Sign Hanger Assembly, Span Wire | 1 | EACH | | |
| 47 | 630 | Sign, Flat Sheet | 27 | SF | | |
| 48 | 644 | Edge Line, 4 Inch, Type 1 | 0.21 | MILE | | |
| 49 | 644 | Center Line, Type 1 | 0.13 | MILE | | |
| 50 | 644 | Channelizing Line, 8 Inch, Type 1 | 592 | FT | | |
| 51 | 644 | Stop Line, Type 1 | 83 | FT | | |
| 52 | 644 | Crosswalk Line, Type 1 | 615 | FT | | |
| 53 | 644 | Lane Arrow, Type 1 | 10 | EACH | | |
| 54 | 644 | Removal of Pavement Markings | 360 | FT | | |
| | | | | | Sub-Total = | |
| | | TRAFFIC SIGNALS | | | | |
| 55 | 632 | Vehicular Signal Head, (LED), 5-Section, 12" Lens, 1-Way, Polycarbonate, Black | 1 | EACH | | |
| 56 | 632 | Covering of Vehicular Signal Head | 1 | EACH | | |
| 57 | 632 | Signal Cable, 7 Conductor, No. 14 AWG | 282 | FT | | |
| 58 | 632 | Removal of Traffic Signal Installation | 1 | EACH | | |
| 59 | 632 | Signalization, Misc.: Unlash and Relash Messenger Wire | 303 | FT | | |
| 60 | 809 | Stop-Line Radar Detection, As Per Plan | 2 | EACH | | |
| | | | | | Sub-Total = | |
| | | MISCELLANEOUS | | | | |
| 61 | 614 | Maintaining Traffic | 1 | LS | | |
| 62 | 624 | Mobilization | 1 | LS | | |
| 63 | 623 | Construction Layout Stakes and Surveying | 1 | LS | | |
| | | | | | Sub-Total = | |
| | | | | | Total = | |

BID PROPOSAL

Proposal for the roadway work on Columbia Road. This work consists of widening for a turn lane, watermain replacement, sidewalk and completing the related roadway items on or near Columbia Road. The project shall be as per plans and specifications as provided by the Warren County Engineer.

The undersigned do hereby propose to furnish all labor, materials, tools, equipment, etc., necessary to construct this project for the Warren County Engineer's Office. The above quotations to be in full force and effect for sixty (60) days after the date of opening bids. The full name and address of all persons and parties interested in the foregoing bids as principals are as follows:

TOTAL BID PRICE \$ _____

The contract will be awarded to the best and most responsive bid based on the qualifications of the Contractor and the total price of the Total Bid Price.

SIGNED

PRESIDENT

COMPANY

SECRETARY

BY

TITLE

DATE

ADDRESS

EXCEPTION SHEET

Exceptions: Exceptions to any bid specification must be clearly stated on this sheet. This sheet must be submitted with each bid. If there are no exceptions, please indicate "none" below.

1) _____

2) _____

3) _____

4) _____

5) _____

6) _____

7) _____

8) _____

9) _____

10) _____

BIDDER IDENTIFICATION

ATTENTION BIDDER:

Please fill out this form and submit with your bid.

COMPANY NAME:

CHIEF EXECUTIVE OFFICER:

ADDRESS:

PHONE NUMBER:

FAX NUMBER:

PROJECT CONTACT PERSON:

PHONE NUMBER:

E-MAIL ADDRESS:

FEDERAL ID #:

WEBSITE ADDRESS:

TABLE OF CONTENTS

Proposal Price (Bid) Sheet
Exception Sheet
Bidder Identification

- A) Invitation to Bidders

Directions to Warren County Administration Building
- B) General Instructions to Bidders
- C) Non-collusion Affidavit
- D) Bid Guaranty & Contract Bond
- E) Performance Bond
- F) Contract
- G) Bond & Insurance Requirements
- H) Experience Statement
- I) Affidavit of Non-Delinquency of Real and/or Personal Property Tax
- J) Non-Discrimination and Equal Employment Opportunity Requirements and Affidavit
- K) Findings for Recovery Affidavit
- L) Wage Rate Determination
- M) Special Provisions/Technical Specifications

SECTION A

INVITATION TO BIDDERS

INVITATION TO BIDDERS

Sealed bids for the Columbia Road Turn Lane Project will be received at the Office of the Warren County Commissioners, 406 Justice Drive, Lebanon, Ohio 45036, until 9:30 a.m., March 15, 2022, and then at said time bids will be publicly opened and read aloud.

Bid documents and specifications are available online at the Warren County's Website at <https://www.co.warren.oh.us/Commissioners/Bids/>. Questions regarding the technical specifications should be directed to Dominic Brigano, Assistant Engineer, at the Warren County Engineer's Office, at (513) 695-3313. **Only ODOT prequalified contractors are eligible to submit bids for this Project.** Pre-qualification status must be in force **at the time of bid, at the time of award, and through the life of the construction contract.**

All bids shall be sealed and plainly marked "**Bid Opening – for Columbia Road Turn Lane Project, March 15, 2022 @ 9:30 a.m.**" Each bid shall contain the full name of each person or company submitting the bid and be accompanied by a bid bond for the full amount of the bid or a certified check in the amount equal to ten (10) percent of the bid.

A Bid guaranty, as required by Ohio Revised Code, Section 153.54, shall accompany each proposal submitted, as follows:

1. A Certified check, cashier's check, or letter of credit equal to ten (10) percent of the bid. A letter of credit may only be revocable by the Owner. Upon entering into a contract with the Owner, the contractor must file a performance bond for the amount of the contract, and the bid guaranty will then be returned to the successful and unsuccessful bidders upon contract execution.

OR

2. A form of bid guaranty bond (attached) for the full amount of the bid. Such bond is retained for the successful bidder but returned to unsuccessful bidders after the contract is executed.

Contact the Warren County Commissioner's Office at (513) 695-1250 should you need assistance in accessing the bidding information on the County's website. All contract addenda will be posted to the website prior to the bid opening. Bidders should check the website regularly to stay updated on any changes to the project.

Please be aware that if you are downloading this document to bid this project, and in order to stay updated on any change, please email Krystal Powell in the Commissioners' Office at krystal.powell@co.warren.oh.us with your contact information.

Attention of bidders is called to all of the requirements contained in the bid packet. No bidder may withdraw his/her bid within sixty (60) days after the actual date of the opening thereof. All bids shall be properly signed by an authorized representative of the bidder.

Warren County reserves the right to reject any or all bids submitted, to waive any irregularities in bids, and enter into a contract with the Bidder who in Warren County's consideration offered the lowest and best bid.

By order of the Board of County Commissioner, County of Warren, State of Ohio.

Tina Osborne, Clerk



DIRECTIONS FROM INTERSTATE HIGHWAYS 71 & 75 TO WARREN COUNTY, OHIO

COUNTY ADMINISTRATION BUILDING



TRI-STATE REGION COUNTIES

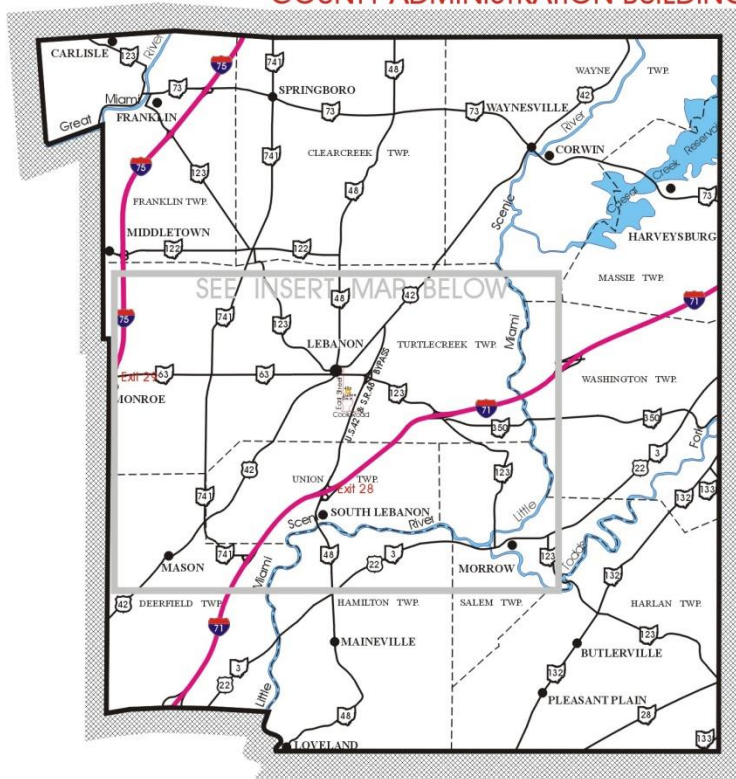

INSERT FROM ABOVE MAP

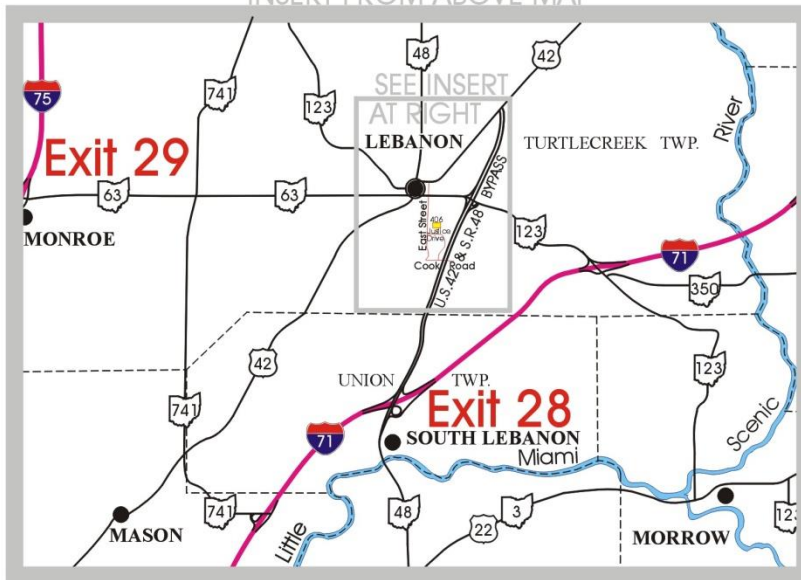

INSERT FROM MAP AT LEFT

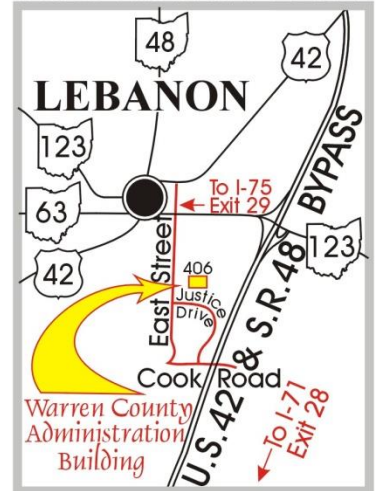

- FROM INTERSTATE 75:**
- Take Monroe / Lebanon Exit 29,
 - Head East on S. R. 63 into Lebanon,
 - Turn right onto East Street,
 - Turn left onto Justice Drive,
 - Turn left into parking lot,
 - At first driveway on left.
- FROM INTERSTATE 71:**
- Take Lebanon / South Lebanon Exit 28,
 - Head North on U. S. 42 / S. R. 48 Bypass,
 - Turn left onto Cook Road at traffic light,
 - Turn at first right onto Justice Drive,
 - Turn right at first street on right,
 - Then left into parking lot at first left.

SECTION B

GENERAL INSTRUCTIONS TO BIDDERS

GENERAL INSTRUCTIONS TO BIDDERS

1. **Receipt and Opening of Bids:** The Warren County Board of Commissioners (herein referred to as "Owner"), invites bids on the form attached hereto, all blanks of which must be appropriately filled in. Bids will be received by the Owner at the Office of the Warren County Board of Commissioners until 9:30 a.m., March 15, 2022, and then at said office publicly opened and read aloud. The envelopes containing the bids must be sealed, addressed to Warren County Board of Commissioners at 406 Justice Drive, Lebanon, Ohio 45036. Bids shall be submitted in a sealed envelope clearly marked "**Bid Opening – Columbia Road Turn Lane Project, March 15, 2022, @ 9:30 a.m.**"

The Owner may consider informal any bid not prepared and submitted in accordance with the provisions hereof and may waive any informalities or reject any and all bids. Any bid may be withdrawn prior to the above scheduled time for the opening of bids or authorized postponement thereof. Any bid received after the time and date specified shall not be considered. No bidder may withdraw a bid within 60 days after the actual date of the opening thereof.

2. **Withdrawal of Bid:** A Bidder may withdraw his bid from consideration if the price bid was substantially lower than the other bids, provided the bid was submitted in good faith and the reason for the price being substantially lower was a clerical mistake as opposed to a judgment mistake and was actually due to an unintentional omission of a substantial quantity of work, labor or material made directly in the compilation of the bid. Request to withdraw such bid must be made in writing and filed with the Owner within two business days after the opening of bids and prior to the acceptance thereof.
3. **Preparation of Bid:** Each bid must be submitted on the prescribed form and such documents as hereunder described. All blank spaces for bid prices must be filled in, in ink or typewritten, in both words and figures, and the foregoing certifications must be fully completed and executed when submitted.
4. **Method of Bidding:** The Owner invites the following bid(s):

Columbia Road Turn Lane Project

Bids shall be submitted at the time and place indicated in the Invitation to Bidder and shall be included in a sealed envelope, marked with the project title and name and address of the bidder, and accompanied by the bid security and other required documents.

Bids may be modified or withdrawn by an appropriate document duly executed (in the manner that a bid must be executed) and delivered to the place where bids are to be submitted at any time prior to the opening of bids.

The Owner invites unit price bids for the construction described in the plans and specifications. These unit prices shall be extended by estimated quantities to develop a total price for the project.

If the total price received from the lowest and best bidder exceeds the amount of funds available to finance the contract, the Owner may:

- a. Reject all bids;
- b. Augment the funds available in an amount sufficient to enable award to the lowest and best bidder;

- c. Reduce the scope of work by eliminating certain items of work to produce a total bid which is within available funds;
 - d. Reduce the scope of work by reducing the quantity of certain items of work to produce a total bid which is within available funds;
 - e. Reduce the scope of work by a combination of adjustments as outlined in "c" and "d" above to produce a total bid which is within available funds.
 - f. The Owner may reject all bids or may award the contract on the base bid or on the base bid combined with additions or deductible alternates as produces a net amount which is within the available funds.
 - g. The Owner may consider informal and may reject any bid not prepared and submitted in accordance with the provisions hereof. The Owner reserves the right to reject all bids, to waive any informalities or irregularities in the bids received, and to accept any bid which is deemed lowest and best.
5. **Qualification of Bidder:** The Owner may make such investigations as he/she deems necessary to determine the ability of the bidder to perform the work, and the bidder shall furnish to the Owner all such information and data for this purpose as the Owner may request. The Owner reserves the right to reject any bid if the evidence submitted by, or investigation of, such bidder fails to satisfy the Owner that such bidder is properly qualified to carry out the obligations of the contract and to complete the work contemplated therein; conditional bids will not be accepted.
6. **Bid Security:** Each bid must be accompanied by cash, certified check of the bidder, letter of credit equal to ten (10) percent of the bid, or a bid bond prepared on the form of bid bond attached hereto, duly executed by the bidder as principal and having as surety thereon a surety company approved by the Owner. (See Invitation to Bidders for required amounts) Such cash, checks or bid bonds will be returned to bidders after the Owner has awarded the bid and has executed the contract, or, if no award has been made within 60 days after the date of the opening of bids, upon demand of the bidder at any time thereafter, so long as he/she has not been notified of the acceptance of his/her bid.
7. **Liquidated Damages for Failure to Enter into Contract:** Submission of a bid shall be a representation by the Contractor that it has fully reviewed and is familiar with the Contract and all contract documents as defined in the contract and will execute the contract if awarded the bid. The successful bidder, upon his/her failure or refusal to execute and deliver the Contract (attached hereto) and required bonds within 10 days after he/she has received notice of the acceptance of his/her bid, shall forfeit to the Owner, as liquidated damages for such failure or refusal, the security deposited with his/her bid.
8. **Time of Completion and Liquidated Damages:** Bidder must agree to commence work on or before a date to be specified in a written "Notice to Proceed" of the Owner and to fully complete 8 weeks after the written notice to proceed has been issued and a pre-construction meeting has been held. The completion date may be extended in the event of adverse weather conditions. Bidder must agree also to pay as liquidated damaged the sum of \$400.00 for each consecutive calendar day thereafter.
9. **NO DAMAGE FOR DELAY:** No payment, compensation or adjustment of any kind shall be made to the contract price for damages incurred by the contractor because of hindrances or delays in the progress of the work from any cause that is not proximately caused by the Owner's action or failure to act. Whether such hindrances or delays are avoidable or unavoidable, the contractor agrees that he or she will make no claim for compensation, damages, or mitigation of liquidated damages for any such delays. Examples of delays include (but are in no manner limited to)

obtaining all necessary permission from any government agency or any private party, any act or failure to act by any other contractor, subcontractor and/or supplier, all foreseen and unforeseen events and any conditions or act of God. It is understood and agreed that the contractor assumes all risks of delays in prosecuting or completing the work under the contract that are not proximately caused by the Owner's action or failure to act. The contractor will accept in full satisfaction for such delays, an extension of time, if any, agreed to by the Owner.

10. **Conditions of Work:** Each bidder must inform him/herself fully of the conditions relating to the construction of the project and the employment of labor thereon. Failure to do so will not relieve a successful bidder of his/her obligation to furnish all material and labor necessary to carry out the provisions of his/her contract. Insofar as possible the contractor, in carrying out the work, must employ such methods or means or will not cause any interruption of or interference with the work of any other contractor.
11. **Addenda and Interpretations:** No interpretation of the meaning of the plans, specifications or other pre-bid documents will be made to any bidder orally. Every request for such interpretation must be in writing and addressed to: Dominic Brigano, Warren County Engineer's Office, 210 West Main Street, Lebanon, Ohio 45036, and to be given consideration must be received at least five days prior to the date fixed for the opening of bids. All such interpretations and any supplemental instructions will be in the form of written addenda to the specifications which, if issued, will be mailed by certified mail with return receipt requested to all prospective bidders (at the respective addresses furnished for such purposes), no later than three days prior to the date fixed for the opening of bids. Failure of any bidder to receive any such addendum or interpretations shall not relieve such bidder from any obligation under his/her bid as submitted. All addenda so issued shall become part of the contract documents.
12. **Security for Faithful Performance:** Simultaneously with the delivery of the executed Contract, the Contractor shall furnish payment and performance bonds as security for faithful performance of this contract and for the payment of all subcontracts, suppliers and laborers performing labor on the project under the Contract and furnishing materials in connection with the Contract.

The surety on such bond or bonds shall be a duly authorized surety company satisfactory to the Owner. Please note that upon execution of the Contract if a Bid Guaranty/Contract Bond was submitted with your original bid a Performance Bond will not be required.
13. **Power of Attorney:** Attorneys-in-fact who sign bid bonds or contract bonds must file with each bond a certified and effectively dated copy of their power of attorney.
14. **Laws and Regulations:** The bidder's attention is directed to the fact that all applicable State laws, municipal ordinances, and the rules and regulations of all authorities having jurisdiction over construction of the project shall apply to the contract throughout, and they will be deemed to be included in the contract the same as though herein written out in full.
15. **Method of Award - Lowest Qualified Bidder:** The Owner may reject all bids or may award the contract on the base bid or on the base bid combined with additions or deductible alternates as produces a net amount which is within the available funds. To determine lowest and best bidder, the price of the bid will be given equal weight against the totality of the following factors:
 - 1.) the bidder's information provided in the Section 00300 Experience Statement which shall be used to judge responsibility, experience, skill, financial standing, feedback from references or prior clients—which may include Owner;

- 2.) the Section 00120 Exception Sheet;
- 3.) availability, proximity, and familiarity to job site.
16. **Obligation of Bidder:** At the time of the opening of bids each bidder will be presumed to have inspected the site and to have read and to be thoroughly familiar with the plans and contract documents (including all addenda). The failure or omission of any bidder to examine any form, instrument or document shall in no way relieve any bidder from any obligation in respect of his/her bid.
17. **Safety Standards and Accident Prevention:** With respect to all work performed under this contract, the Contractor shall:
- a. Comply with the safety standards provisions of applicable laws, building and construction codes and the "Manual of Accident Prevention in Construction" published by the Associated General Contractors of America, the requirements of the Occupational Safety and Health Act of 1970 (Public Law 91-596), and the requirements of title 29 of the code of Federal Regulations, Section 1518 as published in the "Federal Register", Volume 36, N. 75, Saturday, April 17, 1971.
 - b. Exercise every precaution at all times for the prevention of accidents and the protection of persons (including employees) and property.
 - c. Maintain at his/her office or other well-known place at the job site, all articles necessary for giving first aid to the injured and shall make standing arrangements for the immediate removal to a hospital or doctor's care of persons (including employees) who may be injured at the job site. In no case shall employees be permitted to work at a job site before the employer has made a standing arrangement for removal of injured persons to a hospital or a doctor's care.
18. **Examination of Site:** Each bidder shall and is hereby directed to inspect the entire site of the proposed work and judge for him/herself as to all the circumstances affecting the cost and progress of the work and shall assume all patent and latent risks in connection therewith.
19. **Soil Conditions:** Subject to the convenience of the Owner, prospective bidders will be permitted to explore the site by making borings or digging test pits. In such event, the work shall be done at the sole expense and risk of the bidder, and he/she shall maintain and restore the site to original condition. The Owner does not guarantee the accuracy of any information or samples which it may have obtained from test borings or otherwise as to the kind or condition of the soil that may be encountered in the prosecution of the proposed work, neither does the Owner represent that the plans and specifications drawn are based upon any data so obtained. The Owner does not make any representation as to the soil which may be encountered or of soil or water which underlies the work or is adjacent thereto, including any difficulties that may be due to quicksand, or other unfavorable conditions that may be encountered in the work, whether apparent upon surface inspection or disclosed in the process of carrying forward the work.
20. **Water Supply:** All water for construction purposes, as well as the expense of having water conveyed about the work, must be provided by the Contractor and the cost of this work shall be included in the unit prices stipulated for the various items of the work to be done under this contract.
21. **Working Facilities:** The plans show, in the general manner, the existing structures and the land available for construction purposes. The bidders must satisfy themselves of the conditions and difficulties that may be encountered in the execution of the work at this site.

22. **Permits:** The Contractor shall take out all necessary permits from the proper authorities and shall give all notices required by law or ordinance. The charge or fee for any permit issued by the proper authority shall be borne by the contractor.
23. **Signature of Bidders:** The firm, corporate or individual name of the bidder must be signed in ink in the space provided for the signatures on the proposed blanks. In the case of a corporation, the title of the officer signing must be stated, and such officer must be thereunto duly authorized and the seal of said corporation duly affixed. In the case of a partnership, the signature of at least one of the partners must follow the firm name, using the term "member of the firm." In the case of an individual, use the terms "doing business as", or "sole owner." The bidder shall further state in his/her proposal the name and address of each person or corporation interested therein.
24. **Right to Accept or Reject Proposals:** The Owner may consider informal and may reject any bid not prepared and submitted in accordance with the provisions hereof. The Owner reserves the right to reject all bids, to waive any informalities or irregularities in the bids received, and to accept any bid which is deemed lowest and best.
25. **Non-Collusion Affidavit:** The successful bidder will be required to submit a non-collusion affidavit on the form included in these Bid/Contract documents (Section C). This affidavit shall be dated and executed as part of this bid.
26. **EEO Compliance:** Bidders, please see Section J for EEO Compliance Requirements and Affidavit.
27. **Prevailing Wage Rates:** This Project is subject to Prevailing Wage Requirements. In the event that the rate of wages paid for any trade or occupant in the locality where such work is being performed are under current collective agreements or understandings between bona fide organizations of labor and employer, then the wages to be paid shall be not less than such agreed wage rates, nor less than the minimum rates compiled by the Federal Labor Standard Act. A copy of these prevailing wage rates has been included in these specifications as Exhibit N. Every Contractor and Subcontractor who is subject to Ohio Revised Code, Chapter 4115 shall, as soon as he/she begins performance under his/her contract with the Owner, supply the Prevailing Wage Coordinator for the Owner a schedule of the dates on which he/she is required to pay wages to employees. He/ She shall also deliver to the Prevailing Wage Coordinator within three weeks after each pay date, a certified copy of his/her payroll which shall exhibit for each employee paid any wages, name, current address, social security number, number of hours worked each day of the pay period and the total for each week, hourly rate of pay, job classification, fringe payments, and deductions from wages. The certification of each payroll shall be executed by the Contractor, Subcontractor, or duly appointed agent thereof and shall recite that the payroll is correct and complete and that the wage rate shown is not less than those required by the contract.

In case the Owner orders the Contractor to perform extra or additional work which may make it necessary for the Contractor or any Subcontractor under this contract to employ a person not herein specified, the Owner will include in the contract change order for such extra or additional work, a minimum wage rate for such trade or occupation, and insofar as such extra or additional work is concerned, there shall be paid to each employee engaged in work of such trade or occupation, not less than the wage so included. Insofar as possible, local labor shall be employed on this work.

28. **Subletting of Contract:** The Contractor shall not sublet, sell, transfer or assign any portion of the contract without written consent of the Owner or his/her designated agent. When such consent is given, the Contractor will be permitted to sublet a portion thereof, but shall perform with his/her own organization, work amounting to no less than fifty percent of the total contract cost, except that any time designated in the contract before computing the amount of work required to be performed by the

Contractor with his/her own organization, No subcontract, or transfer of contract, shall in any way release the Contractor of his/her liability under the contract and bonds.

29. **Required Insurance:** In accordance with the specifications, the Contractor, without restricting the obligations and liabilities assumed under the Contract Documents, shall at his/her own cost and expense purchase and maintaining in force until final acceptance of his/her work, the forms of insurance coverage listed below.

Certificates from the insurance carrier stating the limits of liability and expiration date shall be filed with the Owner before operations are begun. Such certificates shall not merely name the types of policy provided but **shall specifically refer to this Contract** and shall name the Board of Warren County Commissioners as additionally insured. However, the original policy for Owner's Protective Bodily Injury (Item F) and Property Damages (Item G) shall at this time be delivered to the Owner for its possession.

All policies as hereinafter required shall be so written that the Owner will be notified of cancellation or restrictive amendment at least ten days prior to the effective date of such cancellation or amendment.

Item A - Workers Compensation and/or Employer's liability Insurance as required or specified by State Law.

Item B - Contractor's Direct and Completed Operations Bodily Injury Liability Insurance.

Item C - Contractor's direct and Completed Operations Property Damage Liability Insurance.

Item D - Contractor's Protective Bodily Injury Liability Insurance.

Item E - Contractor's Protective Damage Liability Insurance.

Item F - Owner's Protective Bodily Injury Liability Insurance, naming the Owner as insured.

Item G - Owner's Protective Property Damage Liability Insurance, naming the Owner as insured.

Item H - Bodily Injury Liability Insurance covering motor vehicles either owned by the Contractor or being used in connection with the prosecution of the work embraced under this contract.

Item I - Property Damage Liability Insurance covering motor vehicles either owned by the Contractor or being used in connection with the prosecution of the work embraced under this contract.

Item J - (Where Applicable) Such Protective (including Railroad Protective) and Contractual Bodily Injury Liability Insurance and such Protective (including Railroad Protective) and Contractual Property Damage Liability Insurance as shall be required by the railroad and other utility companies whose property, facilities or rights-of-way may be affected by the work to be done under this contract, in such amounts and in such form as each such utility company may require.

If any part of the work is sublet, insurance of the same types and limits as required by above items numbered A, B, C, D, E, H, and I shall be provided by or on behalf of the Subcontractors to cover that part of the work they have contracted to perform including Property Damage Liability Special Hazards coverage if so required by this contract.

Protective and Contractual Bodily Injury Liability Insurance required by Item J (where applicable) shall be in an amount and form as each railroad or utility company may require.

All Bodily Injury coverage (Items B, D, F, and H) shall be broadened by the inclusion of the term's "occurrence" in lieu of "caused by accident."

In addition to the Contractor's Direct Bodily Injury Liability Insurance (Item B) and the Contractor's Direct Property Damage Liability Insurance (Item C), the Contractor shall also provide Completed Operations Bodily Injury Liability Insurance and Completed Operations Property Damage Liability Insurance for the same amounts as provided for Item B and C during the period of one (1) year after the final acceptance date shall be the date the final estimate is paid to the Contractors. Performance Bond includes material and workmanship for 12 months after completion.

Vendor shall carry Commercial General Liability Insurance coverage. General Aggregate Limit Products – Completed Operations shall be \$2,000,000 Per Occurrence; \$2,000,000 Aggregate Limit, with no interruption of coverage during the entire term of this Agreement; \$1,000,000 Personal and Advertising Injury Limit; Each Occurrence Limit shall be \$1,000,000. Vendor shall also carry Comprehensive Automobile Liability Insurance for owned, non-owned, and hired vehicles. Bodily Injury and Property Damage Liability Limit shall be \$1,000,000 for each occurrence.

Vendor further agrees that if any Comprehensive General Liability or Professional Liability coverage is on a "claims made" basis, the policy provide that in the event this Agreement is terminated, Vendor shall continue such policy in effect for the period of any statute or statutes of limitation applicable to claims thereby insured, notwithstanding the termination of the Agreement.

By endorsement to the Comprehensive General Liability or Professional Liability coverage, Warren County shall be named as an additional insured with the same primary coverage as the principal insured – no policy of Comprehensive General Liability or Professional Liability coverage that provides only excess coverage for an additional insured is permitted.

Vendor shall provide Warren County with a certificate of insurance evidencing such coverage and conditions set forth herein and shall provide thirty (30) day notice of cancellation or non-renewal to Warren County. Such certificates shall provide that the insurer notify Vendee in writing should any of the above-described policies be canceled before the expiration date thereof, to be mailed by the insurer to the Vendee not less than 30 days prior to said cancellation date. Vendor shall also deliver to Lessor, at least 15 days prior to the expiration date of each policy or policies (or of any renewal policy or policies), certificates for the renewal policies of the insurance coverage required herein.

CONSULTANT shall carry statutory worker's compensation insurance as required by law and shall provide CLIENT with certificates of insurance evidencing such coverage simultaneous with the execution of this Agreement

Cancellation or non-renewal of insurance shall be grounds to terminate this Agreement.

Vendor shall carry Builders Risk Insurance and all risk form, including subsidence and theft of materials from the job site. Such coverage shall be maintained until final acceptance of the Contract by the Owner and payable to the Owner for the benefit of the contractor. The limit for Builders Risk shall be the full value of construction.



CERTIFICATE OF LIABILITY INSURANCE

DATE (MM/DD/YYYY)

THIS CERTIFICATE IS ISSUED AS A MATTER OF INFORMATION ONLY AND CONFERS NO RIGHTS UPON THE CERTIFICATE HOLDER. THIS CERTIFICATE DOES NOT AFFIRMATIVELY OR NEGATIVELY AMEND, EXTEND OR ALTER THE COVERAGE AFFORDED BY THE POLICIES BELOW. THIS CERTIFICATE OF INSURANCE DOES NOT CONSTITUTE A CONTRACT BETWEEN THE ISSUING INSURER(S), AUTHORIZED REPRESENTATIVE OR PRODUCER, AND THE CERTIFICATE HOLDER.

IMPORTANT: If the certificate holder is an ADDITIONAL INSURED, the policy(ies) must be endorsed. If SUBROGATION IS WAIVED, subject to the terms and conditions of the policy, certain policies may require an endorsement. A statement on this certificate does not confer rights to the certificate holder in lieu of such endorsement(s).

| | | | | | | | | | | | | | | | | | | | | | |
|--|---|--|--|------------------------------|-----------------------|------------------------|--|--------------------------------------|---------------|---------------------------------------|--|---------------------------------------|--|---------------------------------------|--|---------------------------------------|--|---------------------------------------|--|---------------------------------------|--|
| PRODUCER Insurance Agency Name & Address | <table border="1" style="width: 100%; border-collapse: collapse;"> <tr> <td colspan="2">CONTACT NAME: Insurance Agent Contact</td> </tr> <tr> <td>PHONE (A/C, No, Ext):</td> <td>FAX (A/C, No):</td> </tr> <tr> <td colspan="2">E-MAIL ADDRESS:</td> </tr> <tr> <td style="text-align: center;">INSURER(S) AFFORDING COVERAGE</td> <td style="text-align: center;">NAIC #</td> </tr> <tr> <td>INSURER A: Insurance Company A</td> <td></td> </tr> <tr> <td>INSURER B: Insurance Company B</td> <td></td> </tr> <tr> <td>INSURER C: Insurance Company C</td> <td></td> </tr> <tr> <td>INSURER D: Insurance Company D</td> <td></td> </tr> <tr> <td>INSURER E: Insurance Company E</td> <td></td> </tr> <tr> <td>INSURER F: Insurance Company F</td> <td></td> </tr> </table> | CONTACT NAME: Insurance Agent Contact | | PHONE (A/C, No, Ext): | FAX (A/C, No): | E-MAIL ADDRESS: | | INSURER(S) AFFORDING COVERAGE | NAIC # | INSURER A: Insurance Company A | | INSURER B: Insurance Company B | | INSURER C: Insurance Company C | | INSURER D: Insurance Company D | | INSURER E: Insurance Company E | | INSURER F: Insurance Company F | |
| CONTACT NAME: Insurance Agent Contact | | | | | | | | | | | | | | | | | | | | | |
| PHONE (A/C, No, Ext): | FAX (A/C, No): | | | | | | | | | | | | | | | | | | | | |
| E-MAIL ADDRESS: | | | | | | | | | | | | | | | | | | | | | |
| INSURER(S) AFFORDING COVERAGE | NAIC # | | | | | | | | | | | | | | | | | | | | |
| INSURER A: Insurance Company A | | | | | | | | | | | | | | | | | | | | | |
| INSURER B: Insurance Company B | | | | | | | | | | | | | | | | | | | | | |
| INSURER C: Insurance Company C | | | | | | | | | | | | | | | | | | | | | |
| INSURER D: Insurance Company D | | | | | | | | | | | | | | | | | | | | | |
| INSURER E: Insurance Company E | | | | | | | | | | | | | | | | | | | | | |
| INSURER F: Insurance Company F | | | | | | | | | | | | | | | | | | | | | |
| INSURED Contractors Name & Address | | | | | | | | | | | | | | | | | | | | | |

COVERAGES **CERTIFICATE NUMBER:** **REVISION NUMBER:**

THIS IS TO CERTIFY THAT THE POLICIES OF INSURANCE LISTED BELOW HAVE BEEN ISSUED TO THE INSURED NAMED ABOVE FOR THE POLICY PERIOD INDICATED. NOTWITHSTANDING ANY REQUIREMENT, TERM OR CONDITION OF ANY CONTRACT OR OTHER DOCUMENT WITH RESPECT TO WHICH THIS CERTIFICATE MAY BE ISSUED OR MAY PERTAIN, THE INSURANCE AFFORDED BY THE POLICIES DESCRIBED HEREIN IS SUBJECT TO ALL THE TERMS, EXCLUSIONS AND CONDITIONS OF SUCH POLICIES. LIMITS SHOWN MAY HAVE BEEN REDUCED BY PAID CLAIMS.

| INSR LTR | TYPE OF INSURANCE | ADDL INSD | SUBR WVD | POLICY NUMBER | POLICY EFF (MM/DD/YYYY) | POLICY EXP (MM/DD/YYYY) | LIMITS |
|----------|---|-----------|------------|---------------|-------------------------|-------------------------|--|
| A | <input checked="" type="checkbox"/> COMMERCIAL GENERAL LIABILITY <input type="checkbox"/> CLAIMS-MADE <input checked="" type="checkbox"/> OCCUR GEN'L AGGREGATE LIMIT APPLIES PER: <input type="checkbox"/> POLICY <input checked="" type="checkbox"/> PROJECT <input type="checkbox"/> LOC OTHER: | X | X | POLICY # | EFF DATE | EXP DATE | EACH OCCURRENCE \$ 1,000,000 DAMAGE TO RENTED PREMISES (Ea occurrence) \$ 100,000 MED EXP (Any one person) \$ 5,000 PERSONAL & ADV INJURY \$ 1,000,000 GENERAL AGGREGATE \$ 2,000,000 PRODUCTS - COMP/OP AGG \$ 2,000,000 |
| B | <input checked="" type="checkbox"/> AUTOMOBILE LIABILITY <input type="checkbox"/> ANY AUTO <input type="checkbox"/> SCHEDULED AUTOS <input type="checkbox"/> ALL OWNED AUTOS <input type="checkbox"/> NON-OWNED AUTOS <input type="checkbox"/> HIRED AUTOS | | | POLICY # | EFF DATE | EXP DATE | COMBINED SINGLE LIMIT (Ea accident) \$ 1,000,000 BODILY INJURY (Per person) \$ BODILY INJURY (Per accident) \$ PROPERTY DAMAGE (Per accident) \$ |
| C | <input checked="" type="checkbox"/> UMBRELLA LIAB <input checked="" type="checkbox"/> OCCUR <input type="checkbox"/> EXCESS LIAB <input type="checkbox"/> CLAIMS-MADE DED RETENTION \$ | | | POLICY # | EFF DATE | EXP DATE | EACH OCCURRENCE \$ 1,000,000 AGGREGATE \$ 1,000,000 |
| | WORKERS COMPENSATION AND EMPLOYERS' LIABILITY ANY PROPRIETOR/PARTNER/EXECUTIVE OFFICER/MEMBER EXCLUDED? (Mandatory in NH) If yes, describe under DESCRIPTION OF OPERATIONS below | | Y/N N/A | | | | <input type="checkbox"/> PER STATUTE <input type="checkbox"/> OTH-ER E.L. EACH ACCIDENT \$ E.L. DISEASE - EA EMPLOYEE \$ E.L. DISEASE - POLICY LIMIT \$ |

DESCRIPTION OF OPERATIONS / LOCATIONS / VEHICLES (ACORD 101, Additional Remarks Schedule, may be attached if more space is required)

Board of Warren County Commissions are listed as additional insureds with respects to the General Liability for ongoing and completed operations as per attached CG 2010 10/01 and CG 2037 10/01. General Liability is primary and non-contributory for the benefit of the additional insured. Waiver of subrogation applies to the General Liability.

| | |
|---|--|
| CERTIFICATE HOLDER Board of Warren County Commissioners 406 Justice Drive Lebanon, OH 45036 | CANCELLATION SHOULD ANY OF THE ABOVE DESCRIBED POLICIES BE CANCELLED BEFORE THE EXPIRATION DATE THEREOF, NOTICE WILL BE DELIVERED IN ACCORDANCE WITH THE POLICY PROVISIONS. AUTHORIZED REPRESENTATIVE INSURANCE AGENTS SIGNATURE |
|---|--|

POLICY NUMBER:

COMMERCIAL GENERAL LIABILITY
CG 20 10 10 01

THIS ENDORSEMENT CHANGES THE POLICY. PLEASE READ IT CAREFULLY.

**ADDITIONAL INSURED – OWNERS, LESSEES OR
CONTRACTORS – SCHEDULED PERSON OR
ORGANIZATION**

This endorsement modifies insurance provided under the following:

COMMERCIAL GENERAL LIABILITY COVERAGE PART

SCHEDULE

Name of Person or Organization:

Board of Warren County Commissioners
406 Justice Drive, Lebanon, OH 45036

(If no entry appears above, information required to complete this endorsement will be shown in the Declarations as applicable to this endorsement.)

A. Section II – Who Is An Insured is amended to include as an insured the person or organization shown in the Schedule, but only with respect to liability arising out of your ongoing operations performed for that insured.

B. With respect to the insurance afforded to these additional insureds, the following exclusion is added:

2. Exclusions

This insurance does not apply to "bodily injury" or "property damage" occurring after:

- (1) All work, including materials, parts or equipment furnished in connection with such work, on the project (other than service, maintenance or repairs) to be performed by or on behalf of the additional insured(s) at the site of the covered operations has been completed; or
- (2) That portion of "your work" out of which the injury or damage arises has been put to its intended use by any person or organization other than another contractor or subcontractor engaged in performing operations for a principal as a part of the same project.

POLICY NUMBER:

COMMERCIAL GENERAL LIABILITY
CG 20 37 10 01

THIS ENDORSEMENT CHANGES THE POLICY. PLEASE READ IT CAREFULLY.

**ADDITIONAL INSURED – OWNERS, LESSEES OR
CONTRACTORS – COMPLETED OPERATIONS**

This endorsement modifies insurance provided under the following:

COMMERCIAL GENERAL LIABILITY COVERAGE PART

SCHEDULE

| |
|--|
| Name of Person or Organization: Board of Warren County Commissioners 406 Justice Drive Lebanon, OH 45036 |
| Location And Description of Completed Operations: |
| Additional Premium: |

(If no entry appears above, information required to complete this endorsement will be shown in the Declarations as applicable to this endorsement.)

Section II – Who Is An Insured is amended to include as an insured the person or organization shown in the Schedule, but only with respect to liability arising out of "your work" at the location designated and described in the schedule of this endorsement performed for that insured and included in the "products-completed operations hazard".

POLICY NUMBER:

COMMERCIAL GENERAL LIABILITY
CG 25 03 03 97

THIS ENDORSEMENT CHANGES THE POLICY. PLEASE READ IT CAREFULLY.

DESIGNATED CONSTRUCTION PROJECT(S) GENERAL AGGREGATE LIMIT

This endorsement modifies insurance provided under the following:

COMMERCIAL GENERAL LIABILITY COVERAGE PART

SCHEDULE

| |
|-----------------------------------|
| Designated Construction Projects: |
| |

(If no entry appears above, information required to complete this endorsement will be shown in the Declarations as applicable to this endorsement.)

- A.** For all sums which the insured becomes legally obligated to pay as damages caused by "occurrences" under **COVERAGE A (SECTION I)**, and for all medical expenses caused by accidents under **COVERAGE C (SECTION I)**, which can be attributed only to ongoing operations at a single designated construction project shown in the Schedule above:
1. A separate Designated Construction Project General Aggregate Limit applies to each designated construction project, and that limit is equal to the amount of the General Aggregate Limit shown in the Declarations.
 2. The Designated Construction Project General Aggregate Limit is the most we will pay for the sum of all damages under **COVERAGE A**, except damages because of "bodily injury" or "property damage" included in the "products-completed operations hazard", and for medical expenses under **COVERAGE C** regardless of the number of:
 - a. Insureds;
 - b. Claims made or "suits" brought; or
 - c. Persons or organizations making claims or bringing "suits".
 3. Any payments made under **COVERAGE A** for damages or under **COVERAGE C** for medical expenses shall reduce the Designated Construction Project General Aggregate Limit for that designated construction project. Such payments shall not reduce the General Aggregate Limit shown in the Declarations nor shall they reduce any other Designated Construction Project General Aggregate Limit for any other designated construction project shown in the Schedule above.
- 4.** The limits shown in the Declarations for Each Occurrence, Fire Damage and Medical Expense continue to apply. However, instead of being subject to the General Aggregate Limit shown in the Declarations, such limits will be subject to the applicable Designated Construction Project General Aggregate Limit.
- B.** For all sums which the insured becomes legally obligated to pay as damages caused by "occurrences" under **COVERAGE A (SECTION I)**, and for all medical expenses caused by accidents under **COVERAGE C (SECTION I)**, which cannot be attributed only to ongoing operations at a single designated construction project shown in the Schedule above:
1. Any payments made under **COVERAGE A** for damages or under **COVERAGE C** for medical expenses shall reduce the amount available under the General Aggregate Limit or the Products-Completed Operations Aggregate Limit, whichever is applicable; and
 2. Such payments shall not reduce any Designated Construction Project General Aggregate Limit.
- C.** When coverage for liability arising out of the "products-completed operations hazard" is provided, any payments for damages because of "bodily injury" or "property damage" included in the "products-completed operations hazard" will reduce the Products-Completed Operations Aggregate Limit, and not reduce the General Aggregate Limit nor the Designated Construction Project General Aggregate Limit.

D. If the applicable designated construction project has been abandoned, delayed, or abandoned and then restarted, or if the authorized contracting parties deviate from plans, blueprints, designs, specifications or timetables, the project will still be deemed to be the same construction project.

E. The provisions of Limits Of Insurance (SECTION III) not otherwise modified by this endorsement shall continue to apply as stipulated.

30. **Maintenance of Rights-Of-Way:** All construction as proposed along all City, Township, County, State and Federal roads including storage and stockpiling of materials, is to be conducted within the limits of the public right-of-way. Bracing sheeting and shoring shall be used to keep all construction work within the construction limits unless work agreements are secured from the adjacent property Owners. It is the Contractor's responsibility to secure these work agreements, if deemed necessary. Copies of the work agreements shall be delivered to the Engineer and Owner prior to any work beginning on the affected property.

31. **Lights, Signs and Barricades:** Lights, signs and barricades shall be used to maintain traffic and safety for vehicular and pedestrian traffic during the course of this contract and shall be the sole responsibility of the Contractor.

32. **Foreign Corporation and Contractors:**

Foreign Corporations

Definition: "Foreign Corporation" means a corporation incorporated under the laws of another state. No contract shall be entered into with a foreign corporation until the Secretary of State has certified that such corporation is authorized to do business in Ohio: and until, if the bidder so awarded the Contract is a person or partnership, it has filed with the Secretary of State a Power of Attorney designating the Secretary of State as its agent for the purpose of accepting service of summons in any action brought under Ohio Revised Code, Section 153.05 or under Sections 4123.01 to 4123.94, inclusive.

33. **Subcontracts:** Contractor shall provide an explanation as part of its bid package of all subcontractors intended to be used in performance of the work described in Part II., Section D. In the event the Owner does not object, Contractor may have such work performed by a subcontractor. Contractor shall bind every subcontractor to, and every subcontractor must agree to be bound by the terms of, the Contract, as far as applicable to the subcontractor's work particularly pertaining to Prevailing Wages and EEO requirements. Nothing contained in the Agreement shall create any contractual relationship between any subcontractors and Owner, nor create any obligations on the part of the Owner to pay or see to the payment of any sums to any subcontractor.

34. **Real and/or Personal Property Tax Affidavit:** All bidders must complete the Real and/or Personal property tax affidavit (Section I) and submit with your bid. *This section should be fully completed whether or not you as a vendor/contractor own property in Warren County, Ohio.*

35. **Description of Project:**

See Section M

36. **Scope of Work:** Provide all work as required by Contract and described in the Specifications herein (Section N) as necessary to provide for project completion.

37. **Required Forms:** Each Bidder shall complete and submit the following forms with his/her bid:

Proposal Price (Bid) Sheet
Exception Sheet
Bidder Identification
Non-Collusion Affidavit
Bid Guaranty & Contract Bond
Experience Statement
Affidavit of Non-Delinquency of Taxes

Certificate of Compliance Non-Discrimination and Equal Employment Opportunity Affidavit
Findings for Recovery Affidavit

38. The successful Contractor may be required, at the request of the Owner, to submit a list of sub-contractors and suppliers for said project.
39. **Additional Obligations Upon Contract Award:** Upon award of the bid but prior to execution of the Contract and Notice to Proceed, the Contractor shall submit all of the following documents, completed as required:
 - 1) Contract
 - 2) Required Bonds
 - 3) Payment Draw Schedule (Required for Projects of \$500,000 or more)
 - 4) Certificates of Insurance
40. *Entire bid packet must be completed (except contract – Section F) and returned with bid proposal, as the entire bid packet becomes part of the contract documents.*
41. **STATEMENT: Do not submit confidential documents or documents of any type that contain trade secrets. All materials submitted become public records once opened and may be copied upon request to anybody including competitive bidders.**

SECTION C

NONCOLLUSION AFFIDAVIT

AFFIDAVIT OF NON-COLLUSION

STATE OF _____

COUNTY OF _____

I, _____, holding the title and position of _____ at the firm _____, affirm that I am authorized to speak on behalf of the company, board directors and owners in setting the price on the contract, bid or proposal. I understand that any misstatements in the following information will be treated as fraudulent concealment of true facts on the submission of the contract, bid or proposal.

I hereby swear and depose that the following statements are true and factual to the best of my knowledge:

The contract, bid or proposal is genuine and not made on the behalf of any other person, company or client, INCLUDING ANY MEMBER OF THE WARREN COUNTY BOARD OF COMMISSIONERS.

The price of the contract, bid or proposal was determined independent of outside consultation and was not influenced by other companies, clients, or contractors, INCLUDING ANY MEMBER OF THE WARREN COUNTY BOARD OF COMMISSIONERS.

No companies, clients, or contractors, INCLUDING ANY MEMBER OF THE WARREN COUNTY BOARD OF COMMISSIONERS have been solicited to propose a fake contract, bid or proposal for comparative purposes.

No companies, clients, or contractors, INCLUDING ANY MEMBER OF THE WARREN COUNTY BOARD OF COMMISSIONERS have been solicited to refrain from bidding or to submit any form of noncompetitive bidding.

Relative to sealed bids, the price of the bid or proposal has not been disclosed to any client, company or contractor, INCLUDING ANY MEMBER OF THE WARREN COUNTY BOARD OF COMMISSIONERS and will not be disclosed until the formal bid/proposal opening date.

AFFIANT

Subscribed and sworn to before me this _____ day of _____ 20 _____

(Notary Public),

_____ County.

My commission expires _____ 20 _____

SECTION D

BID GUARANTY AND CONTRACT BOND

BID GUARANTY AND CONTRACT BOND

KNOW ALL MEN BY THESE PRESENTS, that we, the undersigned,

(Insert full name or legal title of Contractor and Address)

as Principal and _____

(Insert full name or legal title of Surety)

as Surety, are hereby held and firmly bound unto the Warren County Board of Commissioners and the Ohio Department of Transportation and hereinafter called the Oblige, in the penal sum of the dollar amount of the bid submitted by the Principal to the Oblige on _____ to undertake the project known as:

Columbia Road Turn Lane Project

The penal sum referred to herein shall be the dollar amount of the Principal's bid to the Oblige, incorporating any additive or deductive alternate proposals made by the Principal on the date referred to above to the Oblige, which are accepted by the Oblige, In no case shall the penal sum exceed the amount of _____ DOLLARS, \$_____.

If this item is left blank, the penal sum will be the full amount of the Principal's bid, including alternates. Alternatively, if completed, the amount stated must not be less than the full amount of the bid, including alternates in dollars and cents. A percentage is not acceptable.

For the payment of the penal sum well and truly to be made we hereby jointly and severally bind ourselves, our heirs, executors, administrators, successors, and assigns.

THE CONDITION OF THE ABOVE OBLIGATION IS SUCH, that whereas the above-named Principal has submitted a bid on the above referred to project;

NOW, THEREFORE, if the Oblige accepts the bid of the Principal and the Principal fails to enter into a proper contract in accordance with the bid, plans, details, specifications, and bills of material; and in the event the Principal pays to the Oblige the difference not to exceed ten percent of the penalty hereof between the amount specified in the bid and such larger amount for which the Oblige may in good faith contract with the next lowest bidder to perform the work covered by the bid; or in the event the Oblige does not award the contract to the next lowest bidder and resubmits the project for bidding, the Principal will pay the Oblige the difference not to exceed ten percent of the penalty hereof between the amount specified in the bid, or the costs, in connection with the resubmission, of printing new contract documents, required advertising, and printing and mailing notices to prospective bidders, whichever is less, then this obligation shall be null and void, otherwise to remain in full force and effect. If the Oblige accepts the bid of the Principal and within TEN days after the awarding of the contract, enters into a proper contract in accordance with the bid, plans, details, specifications, and bills of material, which said contract is made a part of this bond the same as though set forth herein; and

IF THE SAID PRINCIPAL SHALL well and faithfully perform each and every condition of such contract; and indemnify the Oblige against all damage suffered by failure to perform such contract according to the

provisions thereof and in accordance with the plans, details, specifications, and bills of material therefore; and shall pay all lawful claims of subcontractors, materialmen, and laborers, for labor performed and materials furnished in the carrying forward, performing, or completing of said contract: we agreeing and assenting that this undertaking shall be for benefit of any materialman or laborer having a just claim, as well as for the Obligee herein; **THEN THIS OBLIGATION SHALL** be void; otherwise the same shall remain in full force and effect; it being expressly understood and agreed that the liability of the Surety for any and all claims hereunder shall in no event exceed the penal amount of this obligation as herein stated.

THE SAID surety hereby stipulates and agrees that no modifications, omissions, or additions, in or to the terms of said contract or in or to the plans and specifications therefor shall in any wise affect the obligations of said surety on its bond, and it does hereby waive notice of any such modifications, omissions or additions to the terms of the contract or to the work or to the specifications.

SIGNED AND SEALED this ____ day of _____ 2022.

PRINCIPAL

SURETY

By: _____

By: _____

Attorney-in-fact

Title: _____

Surety Agent's Name and Address:

SECTION E
PERFORMANCE BOND

PERFORMANCE BOND

KNOW ALL MEN BY THESE PRESENTS: that

(Name of Contractor)

(Address of Contractor)

a _____, hereinafter called
(Corporation, Partnership or Individual)

Principal, and _____

(Name of Surety)

(Address of Surety)

hereinafter called Surety, are held and firmly bound unto

WARREN COUNTY, OHIO BOARD OF COMMISSIONERS
406 Justice Drive
Lebanon, OH 45036

hereinafter called OWNER, in the penal sum of _____ Dollars, \$(_____) in lawful money of the United States, for the payment of which sum well and truly to be made, we bind ourselves, successors, and assigns, jointly and severally, firmly by these presents.

THE CONDITION OF THIS OBLIGATION is such that whereas, the Principal entered into a certain contract with the OWNER, dated the _____ day of _____, 2022, a copy of which is hereto attached and made a part hereof for the construction of:

NOW, THEREFORE, if the Principal shall well, truly and faithfully perform its duties, all the undertakings, covenants, terms, conditions, and agreements of said contract during the original term thereof, and any extensions thereof which may be granted by the OWNER, with or without notice to the Surety and during the guaranty period(s), and if he/she shall satisfy all claims and demands incurred under such contract, and shall fully indemnify and save harmless the OWNER from all costs and damages which it may suffer by reason of failure to do so, and shall reimburse and repay the OWNER all outlay and expense which the OWNER may incur in making good any default, then this obligation shall be void; otherwise to remain in full force and effect.

PROVIDED, FURTHER, that the said surety, for value received, hereby stipulates and agrees that no change, extension of time, alteration or addition of the terms of the contract or the WORK to be performed thereunder or the SPECIFICATIONS accompanying the same shall in any way affect its obligation on this BOND, and it does hereby waive notice of any such change, extension of time, alteration or addition to the terms of the contract or to the WORK or to the SPECIFICATIONS.

PROVIDED, FURTHER, that no final settlement between the OWNER and the CONTRACTOR shall abridge the right of any beneficiary hereunder, whose claim may be unsatisfied.

IN WITNESS WHEREOF, this instrument is executed in counterparts, each one of which shall be deemed an original, this the _____ day of _____ 2022.

ATTEST: _____
(Principal)

(SEAL) By _____

ATTEST: _____
(SEAL) (Surety)

IMPORTANT: Pursuant to Ohio Revised Code §122.87(A) a surety company is defined as, “. . . a company that is authorized by the department of insurance to issue bonds as a surety”.

SECTION F

CONTRACT

CONTRACT

THIS AGREEMENT, made this _____ day of _____, 2022, with the Warren County Board of Commissioners, 406 Justice Drive, Lebanon, Ohio hereinafter called "Owner" and CONTRACTOR NAME, ADDRESS, doing businesses as (an individual, partner, a corporation) hereinafter called "Contractor."

WITNESSETH: That for and in consideration of the payments and agreements hereinafter mentioned, to be made and performed by the Owner, the Contractor hereby agrees with the Owner to commence and complete the construction described as follows:

Columbia Road Turn Lane Project

hereinafter called the project, for the sum of \$AMOUNT, AMOUNT WRITTEN OUT, and all work in connection therewith, under the terms as stated in the Conditions of the Contract; and as his/her (its or their) own proper cost and expense furnish all the materials, supplies, machinery, equipment, tools, superintendence, labor insurance, and other accessories and services necessary to complete the said project in accordance with the conditions and prices stated in the Proposal, Conditions of the Contract, the Specifications and Contract Documents. "Contract Documents" means and includes the following:

- Proposal Price (Bid) Sheet
- Exception Sheet
- Bidder Identification
- A) Invitation to Bidders
- B) General Instruction to Bidders
- C) Non-collusion Affidavit
- D) Bid Guaranty & Contract Bond
- E) Performance Bond
- F) Contract
- G) Bonding & Insurance Requirements
- H) Experience Statement
- I) Affidavit of Non-Delinquency of Real and/or Personal Property Tax
- J) Equal Employment Opportunity Requirements, Bid Conditions and Non-discrimination and Equal Employment Opportunity Affidavit
- K) Findings for Recovery Affidavit Wage Rate Determination
- L) Federal Davis Bacon Wage
- M) Special Provision/Technical Specifications

The CONTRACTOR hereby agrees to commence work under this contract on or before a date to be specified in a Written "Notice to Proceed" of the OWNER, and to fully complete the project 8 weeks after the written notice to proceed has been issued and a pre-construction meeting has been held. The Contractor further agrees to pay, as liquidated damages, the sum of \$400.00 for each consecutive calendar day thereafter.

This Agreement may be terminated by either party upon written notice in the event of substantial failure by the other party to perform in accordance with the terms of this Agreement. The nonperforming party shall have fifteen calendar days from the date of the termination notice to cure or to submit a plan for cure acceptable to the other party.

OWNER may terminate or suspend performance of this Agreement for OWNER'S convenience upon a written notice to CONTRACTOR. CONTRACTOR shall terminate or suspend performance of the services/work on a schedule acceptable to OWNER.

The CONTRACTOR will indemnify and save the OWNER, their officers and employees, harmless from loss, expenses, costs, reasonable attorney's fees, litigation expenses, suits at law or in equity, causes of action, actions, damages, and obligations arising from (a) negligent, reckless or willful and wanton acts, errors or omissions by CONTRACTOR, its agents, employees, licensees, consultants or subconsultants; (b) the failure of the CONTRACTOR, its agents, employees, licensees, consultants or subconsultants to observe the applicable standard of care providing services pursuant to this agreement; (c) the intentional misconduct of the CONTRACTOR, its agents, employees, licensees, consultants or subconsultants that result in injury to persons or damage to property for which the OWNER may be held legally liable.

The CONTRACTOR does hereby agree to indemnify and hold the OWNER harmless for any and all sums for which the OWNER may be required to pay or for which the OWNER may be held responsible for failure of the CONTRACTOR or any subcontractor to pay the prevailing wage upon this project.

The OWNER agrees to pay the CONTRACTOR in the manner and at such times as set forth in the General Provisions such amounts as required by the Contract Documents.

This Agreement shall be binding upon all parties hereto and their respective heirs, executors, administrators, successors, and assigns.

Contractor shall bind every subcontractor to, and every subcontractor must agree to be bound by the terms of, this Agreement, as far as applicable to the subcontractor's work particularly pertaining to Prevailing Wages and EEO requirements. Nothing contained in this Agreement shall create any contractual relationship between any subcontractor and Owner, nor create any obligations on the part of the Owner to pay or see to the payment of any sums to any subcontractor.

IN WITNESS WHEREOF, the parties hereto have executed, or caused to be executed by their duly authorized officials, this Agreement in two counterparts, each of which shall be deemed an original on the date first above written.

ATTEST:

Warren County Board of Commissioners
(Owner)

Name

Tom Grossmann, President

(Seal)

ATTEST:

NAME
(Contractor)

Name

By: _____
Name

Title

Approved as to Form:

Assistant Prosecutor

SECTION G

BONDING AND INSURANCE REQUIREMENTS

BONDING AND INSURANCE REQUIREMENTS

A state or local unit of government receiving a grant from the federal government which requires contracting for construction of facility improvement shall follow its own requirements relating to bid guarantees, performance bonds, and payment bonds, except for contracts or subcontracts exceeding \$100,000. For contracts or subcontracts exceeding \$100,000, the Federal agency may accept the bonding policy and requirements of the grantee provided the Federal agency has made a determination that the Government's interest is adequately protected. If such a determination has not been made, the minimum requirements shall be as follows:

- a. **A bid guaranty from each bidder.** The "bid guaranty" shall consist of a firm commitment such as a bid bond in the amount of one hundred (100) percent of the bid price, or ten (10) percent of the bid price if certified check or other negotiable instrument accompanying a bid, as assurance the bidder will, upon acceptance of his/her bid, execute such contractual documents as may be required within the time specified.

- b. **A performance bond on the part of the Contractor for 100 percent of the contract price.** A "performance bond" is one executed in connection with a contract to secure fulfillment of all the contractor's obligations under such contract.

SECTION H

EXPERIENCE STATEMENT

SECTION I

***AFFIDAVIT OF NON-DELINQUENCY OF REAL
AND/OR PERSONAL PROPERTY TAX***

THIS SECTION SHOULD BE FULLY COMPLETED WHETHER OR NOT YOU AS A VENDOR/CONTRACTOR OWN PROPERTY IN WARREN COUNTY, OHIO.

AFFIDAVIT

STATE OF _____)
)
COUNTY OF _____) SS:

_____ being duly cautioned and sworn, states as follows:

1. That he/she is _____ of
(Title)

(Name of Contracting Party)

2. That _____ is not presently
(Name of Contracting Party)
charged with any delinquent Real and/or Personal property taxes on the general tax list of
Real and/or Personal property of Warren County.

-OR-

1. That _____ is charged with
(Name of Contracting Party)

delinquent Real and/or Personal property tax on the general tax list of Real and/or Personal property
of Warren County. The amount of delinquent Real and/or Personal property tax due and unpaid
including any due and unpaid penalty and interest is:
\$ _____

Further, affiant states not.

Affiant

Sworn to and subscribed in my presence this ____ day of _____ 2022.

Notary Public

This instrument was prepared by _____.

Note to Fiscal Office: If any Real and/or Personal property taxes are delinquent, you must send a copy of this statement to the County Treasurer within 30 days of the date it is submitted.

WARNING: MAKING A FALSE STATEMENT ON THIS AFFIDAVIT MAY BE PUNISHABLE BY A FINE AND/OR IMPRISONMENT

SECTION J

***EQUAL EMPLOYMENT OPPORTUNITY REQUIREMENTS,
BID CONDITIONS AND
NON-DISCRIMINATION AND EQUAL
EMPLOYMENT OPPORTUNITY AFFIDAVIT***

**EQUAL EMPLOYMENT OPPORTUNITY REQUIREMENTS
AND BID CONDITIONS FOR
WARREN COUNTY CONSTRUCTION PROJECTS**

CERTIFICATE OF COMPLIANCE FOR EEO PURPOSES: (This section applies only to projects that are funded with Federal and State monies)

All bidders on the project **shall** submit together with their bid, a copy of a valid Certificate of Compliance for Equal Employment Opportunity purposes contained herein.

A copy of the Certificate of Compliance is enclosed with this bid response? _____ Yes _____No

BIDDER'S EEO COVENANTS:

Throughout its performance of any contract awarded to it on this project, the bidder agrees to the following covenants:

1. The contractor will not discriminate against any employee or applicant for employment because of race, color, religion, national origin, ancestry, or sex. The contractor will take affirmative action to ensure that applicants are employed, and that employees are treated during employment without regard to their race, color, religion, national origin, ancestry, or sex. Such action shall include, but is not limited to, the following: Employment, upgrading, demotion, or transfer; recruitment or recruitment advertising; layoff or termination; rates of pay or other forms of compensation; and selection for training, including apprenticeship.

The contractor agrees to post in conspicuous places, available to employees and applicants for employment, notices to be provided setting forth the provisions of this nondiscrimination clause.

2. The contractor will in all solicitations or advertisements for employees placed by or on behalf of the prime contractor, state that all qualified applicants will receive consideration for employment without regard to race, color, religion, national origin, ancestry, or sex.
3. The contractor agrees to fully cooperate with the County, the State Equal Employment Opportunity Coordinator and with any other official or agency, or the State or Federal government which seeks to eliminate unlawful employment discrimination, and with all other State and Federal efforts to assure equal employment practices under its contract and the contractor shall comply promptly with all requests and directions from the County, the State Equal Opportunity Coordinator and any of the State of Ohio officials and agencies in this regard, both before and during construction.
4. Full cooperation as expressed in clause (3), above, shall include, but not be limited to, being a witness and permitting employees to be witnesses and complainants in any proceedings involving questions of unlawful employment practices, furnishing all information requested by the County and the State

Equal Employment Opportunity Coordinator, and permitting access to its books, records, and accounts by the County and the State Equal Employment Opportunity Coordinator for purposes of investigation to ascertain compliance with applicable rules, regulations and orders.

5. In the event of the contractor's noncompliance with the nondiscrimination clauses of its contract or with any of the said rules, regulations, or orders, its contract may be canceled, terminated, or suspended in whole or in part and the contractor may be declared ineligible for further County construction contracts.

In the event that is contract is terminated for a material breach of EEO requirements, the contractor shall become liable for any and all damages which shall accrue to the County as a result of said breach.

6. The contractor will require the inclusion of language reflecting these same six covenants within every subcontract or purchase order it executes in the performance of its contract unless exempted by rules, regulations, or orders of the State Equal Employment Opportunity Coordinator so that these provisions will be binding upon each subcontractor or vendor. The contractor will take such as the County may direct as a means of enforcing such provisions, including sanctions for noncompliance; provided, however, that in any litigation with a subcontractor, vendor, or other party as a result of such direction by the County, the contractor may be requested to protect the interests of the County.

The bidder hereby adopts the foregoing covenants?

_____ Yes _____No

PLEASE NOTE: *The bidder's failure to adopt the Bidder's EEO Covenants and complete the foregoing certification will cause the bidder's proposal to be rejected as being non-responsive.*

Notary

(seal)

SECTION K

FINDINGS FOR RECOVERY AFFIDAVIT

FINDINGS FOR RECOVERY AFFIDAVIT

STATE OF _____
COUNTY OF _____, SS:

_____, upon being duly cautioned and sworn, hereby states the following based on personal knowledge:

1) That he/she is _____ (title), of _____ (name of bidder) and authorized to execute this affidavit; and,

2) That _____ (name of bidder) is not a person or entity against whom a finding for recovery has been issued by the Auditor of State, which finding for recovery is unresolved as defined in Ohio Revised Code [General Provisions] Section 9.24 (B); and,

3) That _____ (name of bidder) does not appear in the database of unresolved findings of recovery maintained by the Auditor of State pursuant to Ohio Revised Code [General Provisions] Section 9.24 (D).

Affiant

Sworn to and subscribed in my presence this ____ day of _____, 2022.

Notary Public
My Commission expires: _____

SECTION L

WAGE RATE DETERMINATION



Mike DeWine
Governor

Sheryl Maxfield
Director

PREVAILING WAGE GUIDE

WARREN COUNTY

OHIO DEPARTMENT OF COMMERCE

Division of Industrial Compliance
Bureau of Wage and Hour Administration
6606 Tussing Road, PO Box 4009
Reynoldsburg, Ohio 43068-9009
Phone: 614-644-2239
Fax: 614-728-8639
www.com.ohio.gov
TTY/TDD: 1-800-750-0750

The Ohio Department of Commerce is an Equal Opportunity Employer and Service Provider

This packet of information is provided as a summary of the Prevailing Wage guidelines and responsibilities. The Ohio Revised Code, Chapter 4115 should be referred to for the exact wording of the law. Also included are references and forms which should be helpful in the compliance of the Prevailing Wage Law.

PACKET INFORMATION INDEX

A. The Ohio Department of Commerce-Division of Industrial Compliance, Wage and Hour Administration Investigators and their assigned counties

1. The Wage and Hour Investigators for the State of Ohio are listed with their contact information.
 - a. If you have questions or need assistance pertaining to Prevailing Wage, you can contact the Investigator in your area.

B. Prevailing Wage Guide for Public Authorities

1. Notice of change of the Prevailing Wage Threshold Level.
 - a. A notification will be sent to you when there is a change of the Prevailing Wage threshold level
2. Outline of the Public Authority's responsibilities for Prevailing Wage.
3. Public Authority's Compliance Checklist form.
 - a. A form for tracking the progress of a Prevailing Wage project
4. Request form for Prevailing Wage Rates.
 - a. Prevailing Wage Rates can be obtained on the website www.com.ohio.gov
 - (1) Prevailing Wage Determination Schedule of wages must be attached to and made part of the specifications for the project, and must be printed on the bidding blanks where the work is done by contract.
5. Bid Tabulation form
 - a. A form to be completed and returned to ODOC-DIC-Bureau of Wage and Hour Administration when the contract has been awarded.
6. Prevailing Wage Bonds form
 - a. Information needed to be kept on file by the Prevailing Wage Coordinator when bonds from the Public Authority are used for a project.

C. Prevailing Wage Guidelines for the Public Authority's Coordinator

1. Guideline for the Prevailing Wage Coordinator
 - a. The Prevailing Wage complaint form and instructions can be obtained on the website www.com.ohio.gov
2. Record of the Certified Payroll Reports Received form
 - a. Helpful form for recording the Certified Payroll Reports and the dates received from the contractors and subcontractors.
3. Employee Interview form
 - a. Helpful form for the use by the Prevailing Wage Coordinator when making on-site visits.
4. Employee vs. Independent Contractor
 - a. Helpful questions when determining if a person is an Employee or an Independent Contractor.

D. Prevailing Wage Guide for Contractors

(Incorporate this section in the Specifications or supply copies for the pre-construction meeting.)

1. Outline of responsibilities for the Prevailing Wage Contractor
2. Notification form from the Contractor to the Employee
 - a. The contractor must submit to employees a completed and signed notification form.
 - b. Some Prevailing Wage Coordinators may require a copy of the completed Notification to the Employee form be submitted with the Certified Payroll Reports.
3. Certified Payroll Report form
 - a. The contractor can use any form/format he chooses as long as **ALL** the information has been provided.
4. Certified Payroll Report form instruction sheet
5. Corrected Certified Payroll Report Example
6. Affidavit of Compliance form
 - a. No Public Authority shall make final payment unless the **Final Affidavits** have been filed by the contractors and subcontractors.



Mike DeWine
Governor

Sheryl Maxfield
Director

INVESTIGATORS CONTACT INFORMATION

OHIO DEPARTMENT OF COMMERCE

Division of Industrial Compliance
Bureau of Wage and Hour Administration
6606 Tussing Road, PO Box 4009
Reynoldsburg, Ohio 43068-9009
Phone: 614-644-2239
Fax: 614-728-8639
www.com.ohio.gov
TTY/TDD: 1-800-750-0750

The Ohio Department of Commerce is an Equal Opportunity Employer and Service Provider

OHIO DEPARTMENT OF COMMERCE
 Division of Industrial Compliance
 Bureau of Wage and Hour Administration
 Chief, Stephen Clegg

6606 Tussing Road, PO Box 4009
 Reynoldsburg, Ohio 43068-9009
 614-644-2239
 fax: 614-728-8639
<http://www.com.ohio.gov>

INVESTIGATORS and THEIR HEADQUARTER COUNTY

| | |
|---|---------------------|
| <p>#48 Dave Horvath PO Box 1512 Lima, Ohio 45802-1512 Voice: (419) 302-1200 Fax: (614) 728-8639 Dave.Horvath@com.state.oh.us</p> | <p>Allen *</p> |
| <p>#30 Mike McKee P.O. Box 1342 Cambridge, Ohio 43725-2247 Voice/Fax: (740) 432-1987 Michael.McKee@com.state.oh.us</p> | <p>Guernsey*</p> |
| <p>#56 Shawn Miles P.O. Box 2547 North Canton, Ohio 44720 Voice/Fax: (614) 496-9076 Shawn.Miles@com.state.oh.us</p> | <p>Stark *</p> |
| <p>#37 David Rice P.O. Box 41241 Dayton, Ohio 45441 Voice: (740) 502-0883 Fax: (614) 995-7768 Dave.Rice@com.state.oh.us</p> | <p>Montgomery *</p> |
| <p>#35 Sean Seibert P.O. Box 422 Painesville, Ohio 44077-3938 Voice: (614) 557-8662 Fax: (614) 232-9541 Sean.Seibert@com.state.oh.us</p> | <p>Lake *</p> |
| <p>#11 Kela D. Thompson 6606 Tussing Rd, PO Box 4009 Reynoldsburg, Ohio 43068-9009 Voice: (614) 728-5007 Fax: (614) 232-9537 Kela.Thompson@com.state.oh.us</p> | <p>Franklin *</p> |

*** Headquarter County**

| | |
|---|---|
| <p>Stephen Clegg, Chief 6606 Tussing Road, PO Box 4009 Reynoldsburg, Ohio 43068-9009 Voice: (614) 728-8686 Fax: (614) 728-8639 Stephen.Clegg@com.state.oh.us</p> | <p>#90 Jackie Clark, Supervisor 6606 Tussing Rd, PO Box 4009 Reynoldsburg, Ohio 43068-9009 Voice: (614) 728-5019 Fax: (614) 222-2357 Jackie.Clark@com.state.oh.us</p> |
|---|---|



Mike DeWine
Governor

Sheryl Maxfield
Director

PREVAILING WAGE GUIDE FOR PUBLIC AUTHORITIES

OHIO DEPARTMENT OF COMMERCE

Division of Industrial Compliance
Bureau of Wage and Hour Administration
6606 Tussing Road, PO Box 4009
Reynoldsburg, Ohio 43068-9009
Phone: 614-644-2239
Fax: 614-728-8639
www.com.ohio.gov
TTY/TDD: 1-800-750-0750

The Ohio Department of Commerce is an Equal Opportunity Employer and Service Provider

PREVAILING WAGE THRESHOLD LEVELS

IMPORTANT NOTICE

Before advertising for bids, contracting, or undertaking construction with its own forces, to construct a public improvement, the Public Authority shall have the Ohio Department of Commerce-Division of Industrial Compliance, Bureau of Wage and Hour Administration determine the prevailing rates of wages for workers employed on the public improvement. The wage determination must be included in the project specifications and printed on the bidding blanks where work is done by contract.

| | |
|---|------------------|
| “New” construction threshold for <i>Building Construction</i>: | \$250,000 |
|---|------------------|

| | |
|---|-----------------|
| “Reconstruction, enlargement, alteration, repair, remodeling, renovation, or painting” threshold level for <i>Building Construction</i>: | \$75,000 |
|---|-----------------|

| | |
|---|-----------------|
| As of January 1, 2018: | |
| “New” construction that involves <i>roads, streets, alleys, sewers, ditches and other works connected to road or bridge construction</i> threshold level has been adjusted to: | \$91,150 |

| | |
|---|-----------------|
| “Reconstruction, enlargement, alteration, repair, remodeling, renovation, or painting” that involves <i>roads, streets, alleys, sewers, ditches and other works connected to road or bridge construction</i> threshold level has been adjusted to: | \$27,309 |
|---|-----------------|

- A) Thresholds are to be adjusted biennially by the Director of the Ohio Department of Commerce.
- B) Biennial adjustments to threshold levels are made according to the Building Cost for Skilled Labor Index published by McGraw-Hill’s Engineering News-Record, but may not increase or decrease more than 3% for any year.

If there are questions concerning this notification, please contact:

Ohio Department of Commerce
 Division of Industrial Compliance
 Bureau of Wage and Hour Administration
 6606 Tussing Road, PO Box 4009
 Reynoldsburg, Ohio 43068-9009
 Phone: 614-644-2239
 Fax: 614-728-8639
www.com.ohio.gov

Public Authority Responsibilities
ORC Chapter 4115: Wages and Hours on Public Works
(Prevailing Wage Coordinator)

1. Before advertising for bids, contracting, or undertaking construction with its own forces, to construct a public improvement, the public authority shall have the Ohio Department of Commerce, Division of Industrial Compliance, Bureau of Wage and Hour Administration determine the prevailing rates of wages for workers employed on the public improvement. The wage determination must be included in the project specifications and printed on the bidding blanks where work is done by contract.
 - a) "New" construction has a threshold level of **\$250,000.**
 - b) "Reconstruction, enlargement, alteration, repair, remodeling, renovation, or painting" has a threshold level of **\$75,000.**
 - c) "New" construction that involves roads, streets, alleys, sewers, ditches and other works connected to road or bridge construction has a threshold level of **\$84,314.**
 - d) "Reconstruction, enlargement, alteration, repair, remodeling, renovation, or painting" that involves roads, streets, alleys, sewers, ditches and other works connected to road or bridge construction has a threshold of **\$25,261.**
 - i.) Thresholds are to be adjusted biennially by the Director of Ohio Department of Commerce, Division of Industrial Compliance, Bureau of Wage and Hour Administration.
 - ii.) Biennial adjustments to threshold levels are made according to the Price Deflator for Construction Index, United States Department of Commerce, Bureau of the Census, but may not increase or decrease more than 3% for any year.
2. Every contract for public work shall contain a provision that each worker employed by the contractor or subcontractor, or other person about or upon the public work, must be paid the prevailing rate of wages.
3. If contracts are not awarded or construction undertaken within ninety days (90) from the date of the determination of the prevailing wage there shall be a re-determination of the wage rates before the contract is awarded.
4. Within **seven (7) working days** after the receipt of notification of a change in the prevailing wage rates, the public authority shall notify all affected contractors and subcontractors. If it is determined that a contractor or subcontractor has violated sections 4115.03 to 4115.16 of the Ohio Revised Code because they were not notified as required, **the public authority is liable** for any back wages, fines, damages, court costs and attorney's fees for the period of time covering the receipt of wage changes, until they give the required notice.
5. No public authority shall award a contract for a public improvement to any contractor or subcontractor whose name appears on the list of debarred contractors. This list is filed with the Secretary of State by the Ohio Department of Commerce-Division of Industrial Compliance & Labor-Bureau of Wage and Hour Administration **The filing of the notice of conviction with the secretary of state constitutes notice to all public authorities.** These contractors are prohibited from working on public improvements for periods ranging from one to three years. The list of debarred contractors can be located on the website www.com.ohio.gov/laws
6. A public authority must designate and appoint **one of its own employees** to serve as the Prevailing Wage Coordinator during the life of the contract for constructing the public improvement. A Prevailing Wage Coordinator must be appointed no later than ten days before the first payment of wages by contractors to employees working on the public improvement.

PUBLIC AUTHORITY'S COMPLIANCE CHECKLIST FOR PREVAILING WAGE

| | | |
|-----------------------|-----|---|
| Project: | | Number: |
| Department: | | Phone#: |
| PW Coordinator: | | Phone#: |
| Architect/Engineer: | | Phone#: |
| Contractor: | | Phone#: |
| Contact Person: | | Title: |
| General Contractor: | | Prime Contractor: |
| | | Construction Mgr: |
| Date Completed | | Compliance Item Description |
| | 1. | Request Prevailing Wage Determination Schedule from ODOC-DIC-Wage & Hour |
| | 2. | Received Prevailing Wage Determination Schedule |
| | 3. | Incorporate Determination Schedule in Specs./Bidding Blanks |
| | 4. | Incorporate notice of Prevailing Wage requirements in Invitation for Bids/Notice to Bidders |
| | 5. | Incorporate Prevailing Wage requirements in Contract |
| | 6. | Submit complete Invitation for Bid to ODOC-DIC-Wage & Hour |
| | 7. | Invitation for Bids |
| | 8. | Bid Opening |
| | 9. | Check Listing of Violators |
| | 10. | Award of Contract. (see note) |
| | 11. | Submit Bid Tabulation/Award to ODOC-DIC-WAGE & HOUR |
| | 12. | Notice to Successful Bidder |
| | 13. | Work Commenced...(see note) |
| | 14. | Appoint Prevailing Wage Coordinator |
| | 15. | Received list of Subcontractors' names, addresses, phone #'s & email's |
| | 16. | Received Payroll Date Schedule |
| | 17. | Received Registered Apprenticeship Agreement Certifications |
| | 18. | Received Deduction Agreements |
| | 19. | Received Payroll Reports with Certification...(see attachment) |
| | 20. | Visited project site |
| | 21. | Received Changes to Determination Schedule |
| | 22. | Notice to Contractors of Determination Schedule change |
| | 23. | Request Final Compliance Affidavit from contractors & subcontractors |
| | 24. | Received Final Affidavits from all contractors & subcontractors |
| | 25. | Certify Final Payment |

Note: If contract is not awarded or construction undertaken within 90 days from the date of establishment of the Prevailing Wage Rates, a re-determination of the Prevailing Wage Rates is required.

REQUEST FOR STATE OF OHIO PREVAILING WAGE RATES

| | | |
|------|--|---|
| Date | (Mark (X) One) <input type="checkbox"/> ~ Residential | <input type="checkbox"/> ~ Construction |
|------|--|---|

Project Information (only one project and one county per request form please)

| | | |
|-------------------|--------------|---|
| County of Project | Project Name | This form MUST be filled out COMPETELY & CORRECTLY for us to process your request. Forms not completed correctly will be RETURNED TO THE SENDER. |
| Site Address | City | |

| | |
|------------------------|---|
| Owner/Public Authority | Prevailing Wage Rates can be obtained on the website www.com.ohio.gov |
|------------------------|---|

| | | |
|----------------------------|-------------------|--|
| Address | Telephone Number | ODOC-DIC-WAGE & HOUR DATE STAMP |
| City | Zip Code | |
| PW Coordinator | Telephone Number | |
| Issuing Authority of Bonds | Type of Financing | |

| | |
|---|---|
| Estimated Total Overall Project Cost <input type="checkbox"/> New Construction <input type="checkbox"/> "Old" Construction * A copy of this form will be returned to you with your wage rates. You must send that copy to us with your bid tabulations once the contract has been awarded. | PLEASE MAIL THIS REQUEST TO: Ohio Department of Commerce Division of Industrial Compliance Bureau of Wage & Hour Administration 6606 Tussing Road, PO Box 4009 Reynoldsburg, Ohio 43068-9009 PHONE: (614) 644-2239 FAX: (614) 728-8639 |
|---|---|

| | |
|---------------------------------|-----------------------|
| Expected Date of Contract Award | PHONE: (614) 644-2239 |
| | FAX: (614) 728-8639 |

| | |
|---------------------------|--|
| Projected Completion Date | |
|---------------------------|--|

| | |
|---|--|
| Send Wage Rates to: (contractors are charged \$5.00 per county) | ODOC-DIC-W&H DATE STAMP (bid tab) |
|---|--|

| | |
|---|--|
| <input type="checkbox"/> Mail <input type="checkbox"/> Pick Up <input type="checkbox"/> Federal Express Account Number | |
|---|--|

| | | |
|------|-----------------------------|--|
| Name | Company or Public Authority | |
|------|-----------------------------|--|

| | |
|---------|--|
| Address | |
|---------|--|

| | | |
|------|-----|------------------|
| City | Zip | Telephone Number |
|------|-----|------------------|

* "Old" construction is reconstruction, enlargement, alteration, repair, remodeling, renovation, or painting.

INDUSTRIAL DEVELOPMENT BONDS

| Bond Projects require the Public Authority to keep the following information on file | | | |
|---|------|---------|--------------|
| 1. Type of Bonds issued: | | Amount: | |
| 2. The total cost of the Project: | | | |
| 3. The other type of financing involved in the project: | | | |
| 4. Portion of the project being constructed with each type of financing: | | | |
| 5. Are Prevailing Wage Rates being applied to all construction on the project: <input type="checkbox"/> Yes <input type="checkbox"/> No | | | |
| 6. The name of the political subdivision who issued the bonds: | | | |
| 7. When were the bonds issued: | | | |
| 8. For what purpose were the bonds issued: | | | |
| 9. Who handles the funds once the bonds are sold: | | | |
| 10. Who is the lending institution that purchased the bonds: | | | |
| 11. How are the funds to be paid out: | | | |
| 12. When are the funds to be paid out: | | | |
| 13. Who is the Bond Council: | | | |
| 14. Who has been appointed as the Prevailing Coordinator: | | | |
| PWC Address: | | | |
| City: | OHIO | Zip: | Telephone #: |
| 15. Obtain a copy of the inducement and other official documents for the issuance of the bonds. | | | |



Mike DeWine
Governor

Sheryl Maxfield
Director

PREVAILING WAGE GUIDELINES

FOR THE

PUBLIC AUTHORITY'S

PW COORDINATOR

OHIO DEPARTMENT OF COMMERCE

Division of Industrial Compliance and Labor

Bureau of Wage and Hour Administration

6606 Tussing Road, PO Box 4009

Reynoldsburg, Ohio 43068-9009

Phone: 614-644-2239

Fax: 614-728-8639

www.com.ohio.gov

TTY/TDD: 1-800-750-0750

The Ohio Department of Commerce is an Equal Opportunity Employer and Service Provider

Prevailing Wage Coordinator Guidelines

For more detailed information please refer to Chapter 4115 of the Ohio Revised Code

- A. Attend any pre-bid and/or pre-construction meetings.
 - 1. To explain the prevailing wage rate requirements.
 - 2. To explain the contractor's responsibilities.
- B. Set up and maintain files containing all contractors' and subcontractors' payroll reports, affidavits, and related documents. These files must be available for public inspection.
- C. Obtain from each contractor a list of their subcontractors' names, addresses, telephone numbers, and email addresses.
- D. Require each contractor and subcontractor to provide their project dates. This will be used to make a time schedule for receiving their certified payrolls.
- E. Obtain from each contractor, the name and address of their Bonding\Surety Company.
- F. Obtain from out-of-state corporations, the name and address of their Statutory Agent. (This agent must be located in the State of Ohio and registered with the Ohio Secretary of State.)
 - 1. Records made in connection with the public improvement must not be removed from the State of Ohio for the period of one year following the completion of the project.
- G. Supply contractors with any changes in the Prevailing Wage Rates.
- H. Within two weeks after the first pay, obtain a certified payroll report from each contractor. A certified report is one that is sworn to and signed by the contractor.
 - 1. If the job will exceed four months, all reports after the initial report can be filed once per month. (The initial report must be filed within two weeks.)
 - 2. If the job will last less than four months, all reports are to be filed weekly after the initial report.
- I. Establish and follow procedures to monitor compliance by contractors and subcontractors.
 - 1. Visit project to verify posting requirements and job classifications.
 - 2. Review certified payroll reports to ensure they are submitted in a timely fashion and complete with the following information for each employee:
 - a) Name, current address, and their social security number or last 4 when permitted
 - b) Classification (must be specific for laborers and operators, including level)
 - c) Hours worked on the project
 - d) Hourly rate
 - e) Fringe benefits, if applicable
 - f) Total hours worked for the week (all jobs)
 - g) Gross wages, all deductions, net pay
 - 3. Compare rates and fringes reported to rates in prevailing wage schedule.
- J. Upon completion of the project and prior to the final payment, require an affidavit of compliance from each contractor and subcontractor. **No public authority shall make final payment to any contractor or subcontractor unless the final affidavits have been filed by the respective contractor and subcontractor. (O.R.C. section 4115.07)**
- K. Report any non-compliance to Ohio Department of Commerce, Division of Industrial Compliance, Bureau of Wage & Hour Administration. The PW complaint form and instructions can be obtained on the website www.com.ohio.gov.

RECORD OF THE CERTIFIED PAYROLL REPORTS RECEIVED

| | | |
|-----------------------------|--------------------------|----------------------------------|
| Project: | | Number: |
| Contractor: | | Phone #: Email: |
| General Contractor: | Prime Contractor: | Subcontractor: |
| Date work commenced: | Completed: | Final Affidavit: |

| Payroll | Payroll Date | Date Received | | Payroll | Payroll Date | Date Received |
|---------|--------------|---------------|--|---------|--------------|---------------|
| 1 | | | | 33 | | |
| 2 | | | | 34 | | |
| 3 | | | | 35 | | |
| 4 | | | | 36 | | |
| 5 | | | | 37 | | |
| 6 | | | | 38 | | |
| 7 | | | | 39 | | |
| 8 | | | | 40 | | |
| 9 | | | | 41 | | |
| 10 | | | | 42 | | |
| 11 | | | | 43 | | |
| 12 | | | | 44 | | |
| 13 | | | | 45 | | |
| 14 | | | | 46 | | |
| 15 | | | | 47 | | |
| 16 | | | | 48 | | |
| 17 | | | | 49 | | |
| 18 | | | | 50 | | |
| 19 | | | | 51 | | |
| 20 | | | | 52 | | |
| 21 | | | | 53 | | |
| 22 | | | | 54 | | |
| 23 | | | | 55 | | |
| 24 | | | | 56 | | |
| 25 | | | | 57 | | |
| 26 | | | | 58 | | |
| 27 | | | | 59 | | |
| 28 | | | | 60 | | |
| 29 | | | | 61 | | |
| 30 | | | | 62 | | |
| 31 | | | | 63 | | |
| 32 | | | | 64 | | |

PREVAILING WAGE INVESTIGATION\EMPLOYEE INTERVIEW

Failure to complete this interview form may reduce our ability to recover back wages which may be owed to you.

| | | | |
|---|--------------------------------|---|---------------------------|
| Project: | | Case #: | |
| Address: | | City: | County: |
| Employee Name: | | | Last 4 digits of the SS#: |
| Address: | City: | State: | Zip: |
| Telephone #: (Home) | (Work) | Email: | Best time to be reached: |
| Another source by which we can contact you. (Someone not living at your address): | | | |
| Name: | | Relationship: | Telephone #: |
| Contractor's Name: | | Telephone #: | |
| Address: | | City: | State: Zip: |
| Date hired: | Date started on this project : | Approximate hours - Straight time: | Overtime: |
| Method of recording hours: <input type="checkbox"/> Time Card <input type="checkbox"/> Called into office | | Recorded by: <input type="checkbox"/> Employee <input type="checkbox"/> Foreman | |
| Did you keep a personal record of your hours worked on this project? <input type="checkbox"/> Yes <input type="checkbox"/> No | | Do you have check stubs? <input type="checkbox"/> Yes <input type="checkbox"/> No | |
| Did anyone else keep a personal record ? <input type="checkbox"/> Yes <input type="checkbox"/> No | | If yes, who: | |
| List your job classification(s): | | <input type="checkbox"/> Journeyman <input type="checkbox"/> Helper <input type="checkbox"/> Apprentice - Level | |
| List your specific job duties: | | List tools\equipment used: | |
| Hourly rate of pay for this project: | | Your regular rate of pay: | |
| Fringe benefits paid by contractor: <input type="checkbox"/> None <input type="checkbox"/> Health Insurance <input type="checkbox"/> Life Insurance <input type="checkbox"/> Pension <input type="checkbox"/> Bonus ~ Vacation - Amount _____ <input type="checkbox"/> Holidays - Amount _____ <input type="checkbox"/> Apprenticeship training <input type="checkbox"/> Profit Sharing ~ Other (list): | | | |
| Did you work overtime? <input type="checkbox"/> Yes <input type="checkbox"/> No | | Were hours over 40 per week paid at time and one half? <input type="checkbox"/> Yes <input type="checkbox"/> No | |
| When is your pay day? | | Method of payment: <input type="checkbox"/> Check <input type="checkbox"/> Cash <input type="checkbox"/> Direct Deposit | |
| List names of co-workers on this project: | | | |
| Comments: | | Please provide a detailed list of the dates, times and hours worked within each classification that may apply to the work performed on a separate sheet. | |
| SIGNATURE AND NOTARY | | | |
| Affiant is further informed that Section 2921.13 of the Ohio Revised Code provides a penalty of a misdemeanor of the first degree and that prosecution will be pursued of those persons who "knowingly swear or affirm the truth of a false statement when ...the statement is sworn or affirmed before a notary public..." Sworn to before me and subscribed by the said: | | I hereby certify that this is a true statement to the best of my knowledge and belief. | |
| _____ | | Signature _____ Date _____ | |
| in my presence this _____ day of _____, 20_____. | | Return to: Ohio Department of Commerce Division of Industrial Compliance & Labor Bureau of Wage and Hour Administration 6606 Tussing Road P.O. Box 4009 Reynoldsburg, Ohio 43068-9009 (614) 644-2239 www.com.ohio.gov | |
| _____ Notary Public | | | |
| Signature of PW Coordinator: | | Date: | |

EMPLOYEE VS. INDEPENDENT CONTRACTOR

| | | | | | | |
|----------|---|---|---|-----------------------------|---|------------------------|
| EMPLOYEE | ↔ | <input checked="" type="checkbox"/> YES | Does the employer have the right to control and direct worker? | <input type="checkbox"/> NO | ↔ | INDEPENDENT CONTRACTOR |
| EMPLOYEE | ↔ | <input checked="" type="checkbox"/> YES | Does the worker receive instructions about how and where the work is to be done instead of the employer merely specifying the desired result? | <input type="checkbox"/> NO | ↔ | INDEPENDENT CONTRACTOR |
| EMPLOYEE | ↔ | <input checked="" type="checkbox"/> YES | Is payment based on time spent rather than a set price for the work to be performed? | <input type="checkbox"/> NO | ↔ | INDEPENDENT CONTRACTOR |
| EMPLOYEE | ↔ | <input checked="" type="checkbox"/> YES | Does the worker devote virtually all his working time to the employer rather than offering services to the general public? | <input type="checkbox"/> NO | ↔ | INDEPENDENT CONTRACTOR |
| EMPLOYEE | ↔ | <input checked="" type="checkbox"/> YES | Does the worker performing services make their services available to the general public and/or other businesses? | <input type="checkbox"/> NO | ↔ | INDEPENDENT CONTRACTOR |
| EMPLOYEE | ↔ | <input checked="" type="checkbox"/> YES | Is there a continuing relationship between employer and worker? | <input type="checkbox"/> NO | ↔ | INDEPENDENT CONTRACTOR |
| EMPLOYEE | ↔ | <input checked="" type="checkbox"/> YES | Can the worker be discharged at will? | <input type="checkbox"/> NO | ↔ | INDEPENDENT CONTRACTOR |
| EMPLOYEE | ↔ | <input checked="" type="checkbox"/> YES | Did the employer train the worker for the job? | <input type="checkbox"/> NO | ↔ | INDEPENDENT CONTRACTOR |
| EMPLOYEE | ↔ | <input checked="" type="checkbox"/> YES | Does the employer have employees performing the same work as the independent contractor? | <input type="checkbox"/> NO | ↔ | INDEPENDENT CONTRACTOR |

EMPLOYEE VS. INDEPENDENT CONTRACTOR-continued

EMPLOYEE ↔ YES NO ↔ INDEPENDENT CONTRACTOR

Does the worker perform services personally rather than delegating them to others?

EMPLOYEE ↔ YES NO ↔ INDEPENDENT CONTRACTOR

Does the employer set a specific time when the individual services are to be performed?

EMPLOYEE ↔ YES NO ↔ INDEPENDENT CONTRACTOR

Does the employer furnish the tools and materials used by the worker performing services?

EMPLOYEE ↔ YES NO ↔ INDEPENDENT CONTRACTOR

Is the employer assuming all the financial risk, rather than the worker making a significant financial investment in the job and having the opportunity to realize a profit or loss from the work?

EMPLOYEE ↔ NO YES ↔ INDEPENDENT CONTRACTOR

Does the individual performing the services publicly advertise these services in for example, the newspaper or yellow pages ?

EMPLOYEE ↔ NO YES ↔ INDEPENDENT CONTRACTOR

Does the individual performing the services have a business license?

EMPLOYEE ↔ NO YES ↔ INDEPENDENT CONTRACTOR

Does the individual performing the services operate d.b.a. or under a tradename?



Mike DeWine
Governor

Sheryl Maxfield
Director

PREVAILING WAGE GUIDE FOR CONTRACTORS

OHIO DEPARTMENT OF COMMERCE

Division of Industrial Compliance
Bureau of Wage and Hour Administration
6606 Tussing Road, PO Box 4009
Reynoldsburg, Ohio 43068-9009
Phone: 614-644-2239
Fax: 614-728-8639
www.com.ohio.gov
TTY/TDD: 1-800-750-0750

The Ohio Department of Commerce is an Equal Opportunity Employer and Service Provider

OHIO DEPARTMENT OF COMMERCE
 Division of Industrial Compliance
 Bureau of Wage and Hour Administration
 Chief, Stephen Clegg

6606 Tussing Road, PO Box 4009
 Reynoldsburg, Ohio 43068-9009
 614-644-2239
 fax: 614-728-8639
<http://www.com.ohio.gov>

INVESTIGATORS and THEIR HEADQUARTER COUNTY

| | |
|---|---------------------|
| <p>#48 Dave Horvath PO Box 1512 Lima, Ohio 45802-1512 Voice: (419) 302-1200 Fax: (614) 728-8639 Dave.Horvath@com.state.oh.us</p> | <p>Allen *</p> |
| <p>#30 Mike McKee P.O. Box 1342 Cambridge, Ohio 43725-2247 Voice/Fax: (740) 432-1987 Michael.McKee@com.state.oh.us</p> | <p>Guernsey*</p> |
| <p>#56 Shawn Miles P.O. Box 2547 North Canton, Ohio 44720 Voice/Fax: (614) 496-9076 Shawn.Miles@com.state.oh.us</p> | <p>Stark *</p> |
| <p>#37 David Rice P.O. Box 41241 Dayton, Ohio 45441 Voice/Fax: (740) 502-0883 Dave.Rice@com.state.oh.us</p> | <p>Montgomery *</p> |
| <p>#35 Sean Seibert P.O. Box 422 Painesville, Ohio 44077-3938 Voice: (614) 557-8662 Fax: (614) 232-9541 Sean.Seibert@com.state.oh.us</p> | <p>Lake *</p> |
| <p>#11 Kela D. Thompson 6606 Tussing Rd, PO Box 4009 Reynoldsburg, Ohio 43068-9009 Voice: (614) 728-5007 Fax: (614) 232-9537 kela.thompson@com.state.oh.us</p> | <p>Franklin *</p> |

*** Headquarter County**

| | |
|---|---|
| <p>Stephen Clegg, Chief 6606 Tussing Road, PO Box 4009 Reynoldsburg, Ohio 43068-9009 Voice: (614) 728-8686 Fax: (614) 728-8639 Stephen.Clegg@com.state.oh.us</p> | <p>#90 Jackie Clark, Supervisor 6606 Tussing Rd, PO Box 4009 Reynoldsburg, Ohio 43068-9009 Voice: (614) 728-5019 Fax: (614) 222-2357 Jackie.Clark@com.state.oh.us</p> |
|---|---|



PREVAILING WAGE CONTRACTOR RESPONSIBILITIES

This is a summary of prevailing wage contractors' responsibilities. For more detailed information please refer to Chapter 4115 of the Ohio Revised Code

General Information

Ohio's prevailing wage laws apply to all public improvements financed in whole or in part by public funds when the total overall project cost is fairly estimated to be more than \$250,000 for new construction or \$75,000 for reconstruction, enlargement, alteration, repair, remodeling, renovation, or painting.

Ohio's prevailing wage laws apply to all public improvements financed in whole or in part by public funds when the total overall project cost is fairly estimated to be more than \$91,150 for new construction that involves roads, streets, alleys, sewers, ditches and other works connected to road or bridge construction or \$27,309 for reconstruction, enlargement, alteration, repair, remodeling, renovation, or painting of a public improvement that involves roads, streets, alleys, sewers, ditches and other works connected to road or bridge construction.

- a) Thresholds are to be adjusted biennially by the Administrator of Ohio Department of Commerce, Division of Industrial Compliance and Labor, Bureau of Wage and Hour Administration
- b) Biennial adjustments to threshold levels are made according to the Price Deflator for Construction Index, United States Department of Commerce, Bureau of the Census*, but may not increase or decrease more than 3% for any year

Penalties for violation

Violators are to be assessed the wages owed, plus a penalty of 100% of the wages owed.

Intentional Violations

If an intentional violation is determined to have occurred, the contractor is prohibited from contracting directly or indirectly with any public authority for the construction of a public improvement. Intentional violation means "a willful, knowing, or deliberate disregard for any provision" of the prevailing wage law and includes but is not limited to the following actions:

- Intentional failure to submit payroll reports as required, or knowingly submitting false or erroneous reports.
- Intentional misclassification of employees for the purpose of reducing wages.
- Intentional misclassification of employees as independent contractors or as apprentices.
- Intentional failure to pay the prevailing wage.
- Intentional failure to comply with the allowable ratio of apprentices to skilled workers as required by the regulations established by Ohio Department of Commerce, Division of Industrial Compliance and Labor, Bureau of Wage and Hour Administration.
- Intentionally employing an officer, of a contractor or subcontractor, that is known to be prohibited from contracting, directly or indirectly, with a public authority.



Responsibilities

- A. Pay the prevailing rate of wages as shown in the wage rate schedules issued by the Ohio Department of Commerce, Division of Industrial Compliance and Labor, Bureau of Wage and Hour Administration, for the classification of work being performed.
1. Wage rate schedules include all modifications, corrections, escalations, or reductions to wage rates issued for the project.
 2. Overtime must be paid at time and one-half the employee's base hourly rate. Fringe benefits are paid at straight time rate for all hours including overtime.
 3. Prevailing wages must be paid in full without any deduction for food, lodging, transportation, use of tools, etc.; unless, the employee has voluntarily consented to these deductions in writing. The public authority and the Director of Ohio Department of Commerce, Division of Industrial Compliance and Labor, Bureau of Wage and Hour Administration - must approve these deductions as fair and reasonable. Consent and approval must be obtained before starting the project.
- B. Use of Apprentices and Helpers cannot exceed the ratios permitted in the wage rate schedules.
1. Apprentices must be registered with the U.S. Department of Labor Bureau of Apprenticeship and Training.
 2. Contractors must provide the Prevailing Wage Coordinator a copy of the Apprenticeship Agreement for each apprentice on the project.
- C. Keep full and accurate payroll records available for inspection by any authorized representative of the Ohio Department of Commerce, Division of Industrial Compliance, and Labor, Bureau of Wage and Hour Administration or the contracting public authority, including the Prevailing Wage Coordinator. Records should include but are not limited to:
1. Time cards, time sheets, daily work records, etc.
 2. Payroll ledger/journals and canceled checks/check register.
 3. Fringe benefit records must include program, address, account number, & canceled checks.
 4. Records made in connection with the public improvement must not be removed from the State for one year following the completion of the project.
 5. Out-of-State Corporations must submit to the Ohio Secretary of State the full name and address of their Statutory Agent in Ohio.
- D. Prevailing Wage Rate Schedule must be posted on the job site where it is accessible to all employees.
- E. Prior to submitting the initial payroll report, supply the Prevailing Wage Coordinator with your project dates to schedule reporting of your payrolls.
- F. Supply the Prevailing Wage Coordinator a list of all subcontractors including the name, address, and telephone number for each.
1. **Contractors are responsible for their subcontractors' compliance with requirements of Chapter 4115 of the Ohio Revised Code.**



- G. Before employees start work on the project, supply them with written notification of their job classification, prevailing wage rate, fringe benefit amounts, and the name of the Prevailing Wage Coordinator for the project. A copy of the completed signed notification should be submitted to Prevailing Wage Coordinator.
- H. Supply all subcontractors with the Prevailing Wage Rates and changes.
- I. Submit certified payrolls within two (2) weeks after the initial pay period. Payrolls must include the following information:
 - 1. Employees' names, addresses, and social security numbers.
 - a. Corporate officers/owners/partners and any salaried personnel who do physical work on the project are considered employees. All rate and reporting requirements are applicable to these individuals.
 - 2. Employees' work classification.
 - a. Be specific about the laborers and/or operators (Group)
 - b. For all apprentices, show level/year and percent of journeyman's rate
 - 3. Hours worked on the project for each employee.
 - a. The number of hours worked in each day and the total number of hours worked each week.
 - 4. Hourly rate for each employee.
 - a. The minimum rate paid must be the wage rate for the appropriate classification. The Department's Wage Rate Schedule sets this rate.
 - b. All overtime worked is to be paid at time and one-half for all hours worked more than forty (40) per week.
 - 5. Where fringes are paid into a bona fide plan instead of cash, list each benefit and amount per hour paid to program for each employee.
 - a. When the amount contributed to the fringe benefit plan and the total number of hours worked by the employee on all projects for the year are documented, the hourly amount is calculated by dividing the total contribution of the employer by the total number of hours worked by the employee.
 - b. When the amount contributed to the fringe benefit is documented but not the total hours worked, the hourly amount is calculated by **dividing the total yearly contribution by 2080**.
 - 6. Gross amount earned on all projects during the pay period.
 - 7. Total deductions from employee's wages.
 - 8. Net amount paid.
- J. The reports shall be certified by the contractor, subcontractor, or duly appointed agent stating that the payroll is correct and complete; and that the wage rates shown are not less than those required by the O.R.C. 4115.
- K. Provide a Final Affidavit to the Prevailing Wage Coordinator upon the completion of the project.

PREVAILING WAGE NOTIFICATION to EMPLOYEE

4115.05...the contractor or subcontractor shall furnish each employee **NOT covered by a collective bargaining agreement** written notification of the job classification to which the employee is assigned, the prevailing wage determined to be applicable to that classification, separated into the hourly rate of pay and the fringe payments, and the identity of the prevailing wage coordinator appointed by the public authority. The contractor or subcontractor shall furnish the same notification to each affected employee every time the job classification of the employee is changed.

| Project Name: | Job Number: |
|-----------------------------|------------------------|
| Contractor: | |
| Project Location: | |
| Prevailing Wage Coordinator | Employee |
| Public Authority: | Name: |
| Name of PWC: | Street: |
| Street: | City: |
| City: | State/Zip: |
| State/Zip: | Phone: |
| | Email: |
| Phone: | Last 4 Digits of SS #: |

You will be performing work on this project that falls under these classifications. You will be paid the appropriate rate for the type of work you are performing.

| Classification: | Prevailing Wage Rate Total Package: | Minus your fringe benefits *: | Your hourly base rate and overtime: |
|-----------------|-------------------------------------|-------------------------------|-------------------------------------|
| | | | / |
| | | | / |
| | | | / |
| | | | / |
| | | | / |
| | | | / |

Hourly fringe benefits paid on your behalf by this company (Yearly amount the company pays divided by 2080):

| Fringe | Amount | Fringe | Amount |
|------------------|--------|-------------------------------|--------|
| Health Insurance | | Vacation | |
| Life Insurance | | Holiday | |
| Pension | | Sick Pay | |
| Other (Specify) | | Training | |
| Other (Specify) | | Total Hourly Fringes * | |

| | |
|-------------------------|-------|
| Contractor's Signature: | Date: |
| Employee's Signature: | Date: |

INSTRUCTIONS FOR PREPARING CERTIFIED PAYROLL REPORTS

General

Contractors and subcontractors are required by law to submit certified payroll reports for work on projects covered by Ohio's Prevailing Wage Law. This form meets the reporting requirements established by Ohio Revised Code Chapter 4115. The use of this form is not mandatory; employers may submit their own forms provided that all of the required information is included. This form may be reproduced, or additional copies obtained from:

Ohio Department of Commerce
Division of Industrial Compliance and Labor
Bureau of Wage & Hour Administration
6606 Tussing Rd, P. O. Box 4009
Reynoldsburg, OH 43068-9009
Phone: (614) 644-2239
www.com.ohio.gov

Certified Payroll Heading

Employer name and address: Company's full name and address... Indicate if the company is a subcontractor.

Subcontractor: Check and list the name of the General Contractor or Prime.

Project: Name and location of the project, including county.

Contracting Public Authority: Name and address of the contracting public authority... (Owner of the project).

Week Ending: Month, day, and year for the last day of the reporting period.

Payroll #: Indicate first, second, third, etc. payroll filed by the company for the project.

Page Indicator: number of pages included in the report.

Project Number: Determined by the public authority... if there is no number leave it blank.

Payroll Information by Column

- Employee Name, Address and Social Security number:** This information must be provided for all employees that perform physical labor on the project. Corporate officers, partners, and salaried employees are considered employees and must be paid the prevailing rate. Individual sole proprietors do not have to pay themselves prevailing rate but must report their hours on the project.
- Work Class:** List classification of work actually performed by employee. If unsure of work classification, consult the Ohio department of Commerce, Wage and Hour Bureau. Employees working more than one classification should have separate line entries for each classification. Indicate what year/level for Apprentices. Be specific when using laborer and operator classifications; for example, Backhoe Operator or Asphalt Laborer.
- Hours Worked, Day & Date:** In the first row of column 3 enter days of pay period example; M T W T H F S S. The second row is for the date that corresponds with each day for the pay period. In the employee information section enter the number of hours worked on the prevailing wage project and which day the hours were worked. Separate rows are labeled for (ST) straight time hours and (OT) overtime hours. All hours worked after 40, must be paid at the appropriate overtime rate.
- Project Total Hours:** Total the hours entered for pay period.
- Base Rate:** Enter actual rate per hour paid to the employee. The overtime hourly rate is time and one-half the base rate listed in the prevailing wage schedule plus fringe benefits at straight time rate. The prevailing wage schedule lists the base rate plus fringe benefit amounts. These amounts added together equal the total prevailing wage rate. Employers must pay this total amount in one of three ways.
 - Total rate may be paid in entirety in the base rate to the employee; in which case, the cash designation will be checked for fringe benefits.
 - Total rate may be paid as listed in prevailing wage rate schedule with total fringe amounts paid approved plans.
 - Total rate may be paid with a combination of base rate and fringe payments to approved plans in amounts other than those listed in schedule.
- Project Gross:** Enter total gross wages earned on the project for straight time and overtime. Project hours X base rate should equal project gross.
- Fringes:** If fringe benefits are paid in the hourly base rate, indicate this by marking the **Cash** space. If fringe benefits are paid to approved plans as listed in the prevailing wage rate schedule, mark the space **Approved Plans**. If fringe benefits are paid partially in the base rate and partially to approved plans, mark the space **Cash & Approved plans**. List the hourly amount paid to approved plans for each fringe. If payments are not made on a per hour basis, **calculate the hourly fringe credit by dividing the yearly employer contribution by** the lesser of: hours actually worked in the year (these must be documented) or **2080**. Fringe benefits include: **Employer's share** of health insurance, life insurance, retirement plan, bonus/profit sharing, sick pay, holiday pay, personal leave, vacation, and education/training programs. If unsure of a possible fringe benefit, contact the Ohio Department of Commerce - Division of Industrial Compliance and Labor - Bureau of Wage & Hour Administration.
- Total Hours All Jobs:** Total all hours worked during the pay period including non-prevailing wage jobs.
- Total Gross All Jobs:** Gross amount earned in the pay period for all hours worked.
- Self explanatory.
- Self explanatory.

Certified Payroll Report

Report for: Check if Subcontractor¹⁾ Contract No: _____ Payroll No: _____
 Company: ¹⁾ _____ If Sub, GC/Prime Contractor Name: _____
 Address: _____ Project Name & Location: _____
 City, State, Zip _____ Public Authority (Owner): _____ Week Ending: _____
 Phone No: _____ Sheet:²⁾ _____ of _____

| 1. Employee Name, Address, & SS# (Last 4 digits if permitted) | 2. Work Class ³⁾ | 3. Prevailing Wage Project Hours Worked - Day & Date | | 4. Total Hours | 5. Base Rate | 6. Project Gross | 7. Fringes: | | | | | 8. Total Hrs for all Jobs | Weekly Payroll Amount | | | | | |
|---|-----------------------------|--|--|----------------|--------------|------------------|--|------|-----|-----|-------|---------------------------|----------------------------|----------------------|-------------------------|-------|--|--|
| | | | | | | | Fringe Rate Your Company Pays Per Hour | | | | | | 9. Total Gross on All Jobs | 10. Total Deductions | 11. Net Pay on All Jobs | | | |
| | | | | | | | H&W | Pens | Vac | Hol | Other | | | | | Total | | |
| | | | | | | | | | | | | | | | | | | |
| | OT | | | | | | | | | | | | | | | | | |
| | ST | | | | | | | | | | | | | | | | | |
| | OT | | | | | | | | | | | | | | | | | |
| | ST | | | | | | | | | | | | | | | | | |
| | OT | | | | | | | | | | | | | | | | | |
| | ST | | | | | | | | | | | | | | | | | |
| | OT | | | | | | | | | | | | | | | | | |
| | ST | | | | | | | | | | | | | | | | | |
| | OT | | | | | | | | | | | | | | | | | |
| | ST | | | | | | | | | | | | | | | | | |

1) By signing below, I certify that: (1) I pay, or supervise the payment of the employees shown above; (2) during the pay period reported on this form, all hours worked on this project have been paid at the appropriate prevailing wage rate for the class of work done; (3) the fringe benefits have been paid as indicated above; (4) no rebates or deductions have been or will be made, directly or indirectly from the total wages earned, other than permissible deductions as defined in ORC Chapter 4115; and (5) apprentices are registered with the U.S. Dept. of Labor, Bureau of Apprenticeship and Training. I understand that the willful falsification of any of the above statements may subject the Contractor or Subcontractor to civil or criminal prosecution.

Type or Print Name and Title _____ Signature _____ Date _____

²⁾ Attach additional sheets as necessary. ³⁾ Type in continuous line, text will wrap.

DO NOT REDO FORM AND CHANGE RATES IF AN ERROR HAS BEEN MADE! SUBMIT A CORRECTED REPORT

*** CORRECTED ***

Certified Payroll Report

Fill out all other areas of the form as usual

Total Hours being corrected for this indiv.

Difference in base rate & corrected base rate if applicable

Report for: Check if Subcontractor¹⁾ Contract No: _____ Payroll No: _____
 Company: ¹⁾ If Sub, GC/Prime Contractor Name: _____
 Address: _____ Project Name & Location: _____ Week Ending: _____
 City, State, Zip _____ Public Authority (Owner): _____
 Phone No: _____ Sheet²⁾ of _____

| 1. Employee Name, Address, & SSN (Last 4 digits if permitted) | 2. Work Class ³⁾ | 3. Prevailing Wage Project Hours Worked - Day & Date | 4. Total Hours | 5. Base Rate | 6. Project Gross | 7. Fringes: | | | | | 8. Total Hrs for all Jobs | 9. Total Gross on All Jobs | 10. Total Deductions | 11. Net Pay on All Jobs |
|---|-----------------------------|--|----------------|--------------|------------------|-----------------------------------|--------------------------|----------------|------|-----|---------------------------|----------------------------|----------------------|-------------------------|
| | | | | | | Cash | | Approved Plans | | | | | | |
| | | | | | | IF Sub, GC/Prime Contractor Name: | Project Name & Location: | H&W | Pens | Vac | | | | |
| Name Address Last 4 SSN | Class | | | | | | | | | | | | | |
| | | | | | | | | | | | | | | |
| | | | | | | | | | | | | | | |
| | | | | | | | | | | | | | | |
| | | | | | | | | | | | | | | |
| | | | | | | | | | | | | | | |
| | | | | | | | | | | | | | | |
| | | | | | | | | | | | | | | |
| | | | | | | | | | | | | | | |
| | | | | | | | | | | | | | | |
| | | | | | | | | | | | | | | |
| | | | | | | | | | | | | | | |

Put the period that is being corrected, i.e.: Oct 26 to Nov 02, not individual weekly dates

Difference in fringes & corrected fringes if applicable.

The net paid will be the total of difference paid and the total hours being corrected. Provide check # in the margin.

1) By signing below, I certify that: (1) I pay, or supervise the payment of the employees shown above; (2) during the pay period reported on this form, all hours worked on this project have been paid at the appropriate prevailing wage rate for the class of work done; (3) the fringe benefits have been paid as indicated above; (4) no rebates or deductions have been or will be made, directly or indirectly from the total wages earned, other than permissible deductions as defined in ORC Chapter 4115; and (5) apprentices are registered with the U.S. Dept. of Labor, Bureau of Apprenticeship and Training. I understand that the willful falsification of any of the above statements may subject the Contractor or Subcontractor to civil or criminal prosecution.

Type or Print Name and Title _____ Signature _____ Sign _____ Date _____
 Complete _____

11/14 jc ²⁾ Attach additional sheets as necessary. ³⁾ Type in continuous line, text will wrap.

Send cover letter stating what happened along with a signed letter from the employee acknowledging that they were underpaid, received payment, check or transaction number. Contractor provided cancelled endorsed bank check.

IMPORTANT NOTICE - This process may be different if the Public Authority is using LCPTracker or some other online system to collect Certified Payroll Report from the contractors.



Affidavit of Compliance
Prevailing Wages

I, _____ (Name of person signing affidavit) (Title)

do hereby certify that the wages paid to all employees of

_____ (Company Name)

for all hours worked on the

_____ (Project name and location)

project, during the period from _____ to _____ are in (Project Dates)

compliance with prevailing wage requirements of Chapter 4115 of the Ohio Revised Code. I further certify that no rebates or deductions have been or will be made, directly or indirectly, from any wages paid in connection with this project, other than those provided by law.

_____ (Signature of Officer or Agent)

Sworn to and subscribed in my presence this _____ day of _____, 20_____.

_____ (Notary Public)

The above affidavit must be executed and sworn to by the officer or agent of the contractor or subcontractor who supervises the payment of employees. This affidavit must be submitted to the owner (public authority) before the surety is released or final payment due under the terms of the contract is made.

THIS PAGE WAS LEFT BLANK INTENTIONALLY

Prevailing Wage Determination Cover Letter

County: ▼
Determination Date: 05/11/2020
Expiration Date: 08/11/2020

THE FOLLOWING PAGES ARE PREVAILING RATES OF WAGES ON PUBLIC IMPROVEMENTS FAIRLY ESTIMATED TO BE MORE THAN THE AMOUNT IN O.R.C. SEC. 4115.03 (b) (1) or (2), AS APPLICABLE.

Section 4115.05 provides, in part: "Where contracts are not awarded or construction undertaken within ninety days from the date of the establishment of the prevailing wages, there shall be a redetermination of the prevailing rate of wages before the contract is awarded." The expiration date of this wage schedule is listed above for your convenience only. This wage determination is not intended as a blanket determination to be used for all projects during this period without prior approval of this Department.

Section 4115.04, Ohio Revised Code provides, in part: "Such schedule of wages shall be attached to and made a part of the specifications for the work, and shall be printed on the bidding blanks where the work is done by contract..."

The contract between the letting authority and the successful bidder shall contain a statement requiring that mechanics and laborers be paid a prevailing rate of wage as required in Section 4115.06, Ohio Revised Code.

The contractor or subcontractor is required to file with the contracting public authority upon completion of the project and prior to final payment therefore an affidavit stating that he has fully complied with Chapter 4115 of the Ohio Revised Code.

The wage rates contained in this schedule are the "Prevailing Wages" as defined by Section 4115.03, Ohio Revised Code (the basic hourly rates plus certain fringe benefits). These rates and fringes shall be a minimum to be paid under a contract regulated by Chapter 4115 of the Ohio Revised Code by contractors and subcontractors. The prevailing wage rates contained in this schedule include the effective dates and wage rates currently on file. In cases where future effective dates are not included in this schedule, modifications to the wage schedule will be furnished to the Prevailing Wage Coordinator appointed by the public authority as soon as prevailing wage rates increases are received by this office.

"There shall be posted in a prominent and accessible place on the site of work a legible statement of the Schedule of Wage Rates specified in the contract to the various classifications of laborers, workmen, and mechanics employed, said statement to remain posted during the life of such contract." Section 4115.07, Ohio Revised Code.

Apprentices will be permitted to work only under a bona fide apprenticeship program if such program exists and if such program is registered with the Ohio Apprenticeship Council.

Section 4115.071 provides that no later than ten days before the first payment of wages is due to any employee of any contractor or subcontractor working on a contract regulated by Chapter 4115, Ohio Revised Code, the contracting public authority shall appoint one of his own employees to act as the prevailing wage coordinator for said contract. The duties of the prevailing wage coordinator are outlined in Section 4115.071 of the Ohio Revised Code.

Section 4115.05 provides for an escalator in the prevailing wage rate. Each time a new rate is established, that rate is required to be paid on all ongoing public improvement projects.

A further requirement of Section 4115.05 of the Ohio Revised Code is: "On the occasion of the first pay date under a contract, the contractor shall furnish each employee not covered by a collective bargaining agreement or understanding between employers and bona fide organizations of Labor with individual written notification of the job classification to which the employee is assigned, the prevailing wage determined to be applicable to that classification, separated into the hourly rate of pay and the fringe payments, and the identity of the prevailing wage Coordinator appointed by the public authority. The contractor or subcontractor shall furnish the same notification to each affected employee every time the job classification of the employee is changed."

Work performed in connection with the installation of modular furniture may be subject to prevailing wage.

THIS PACKET IS NOT TO BE SEPARATED BUT IS TO REMAIN COMPLETE AS IT IS SUBMITTED TO YOU. (Reference guidelines and forms are included in this packet to be helpful in the compliance of the Prevailing Wage law.)

wh1500

Prevailing Wage Rate Skilled Crafts

Name of Union: Asbestos Local 50 Zone 1

Change # : LCR01-2021sksLoc50

Craft : Asbestos Worker Effective Date : 12/17/2021 Last Posted : 12/17/2021

| | BHR | | Fringe Benefit Payments | | | | | Irrevocable Fund | | Total PWR | Overtime Rate | |
|------------------------------|---------|---------|-------------------------|---------|---------|--------|---------|------------------|-----------|-----------|---------------|----------|
| | | | H&W | Pension | App Tr. | Vac. | Annuity | Other | LECET (*) | | | MISC (*) |
| Classification | | | | | | | | | | | | |
| Asbestos Insulation Mechanic | \$34.36 | | \$7.70 | \$7.85 | \$0.50 | \$0.00 | \$2.90 | \$0.05 | \$0.00 | \$0.00 | \$53.36 | \$70.54 |
| Firestop Technician | \$34.36 | | \$7.70 | \$7.85 | \$0.50 | \$0.00 | \$2.90 | \$0.05 | \$0.00 | \$0.00 | \$53.36 | \$70.54 |
| Apprentice | Percent | | | | | | | | | | | |
| 1st year | 53.72 | \$18.46 | \$7.46 | \$0.00 | \$0.44 | \$0.00 | \$0.25 | \$0.05 | \$0.00 | \$0.00 | \$26.66 | \$35.89 |
| 2nd year | 65.09 | \$22.36 | \$7.70 | \$0.95 | \$0.44 | \$0.00 | \$0.50 | \$0.05 | \$0.00 | \$0.00 | \$32.00 | \$43.19 |
| 3rd year | 75.72 | \$26.02 | \$7.70 | \$2.38 | \$0.44 | \$0.00 | \$0.75 | \$0.05 | \$0.00 | \$0.00 | \$37.34 | \$50.35 |
| 4th year | 83.51 | \$28.69 | \$7.70 | \$2.38 | \$0.44 | \$0.00 | \$0.75 | \$0.05 | \$0.00 | \$0.00 | \$40.01 | \$54.36 |

Special Calculation Note : *other is Labor Mgt Training Fund

Ratio :

- 1 Journeymen to 1 Apprentice
- 4 Journeymen to 1 Apprentice thereafter

Jurisdiction (* denotes special jurisdictional note) :

ATHENS, AUGLAIZE, BUTLER*, CLINTON, CRAWFORD, DELAWARE, FAIRFIELD, FAYETTE, FRANKLIN, GUERNSEY, HARDIN, HOCKING, KNOX, LICKING, LOGAN, MADISON, MARION, MORGAN, MORROW, MUSKINGUM, NOBLE, PERRY, PICKAWAY, ROSS, SHELBY, UNION, VINTON, WARREN*

Special Jurisdictional Note : Township of Butler County-Townships of Lemon and Madison. Warren County-Township of Cleer Creek, Franklin, Massie, Turtle Creek and Wayne

Details :

Prevailing Wage Rate Skilled Crafts

Name of Union: Asbestos Local 8 Heat & Frost Insulators

Change # : LCN01-2021fbAsbLoc8

Craft : Asbestos Worker Effective Date : 03/10/2021 Last Posted : 03/10/2021

| | BHR | | Fringe Benefit Payments | | | | | Irrevocable Fund | | Total PWR | Overtime Rate | |
|---------------------|---------|---------|-------------------------|---------|---------|--------|---------|------------------|-----------|-----------|---------------|----------|
| | | | H&W | Pension | App Tr. | Vac. | Annuity | Other | LECET (*) | | | MISC (*) |
| Classification | | | | | | | | | | | | |
| Asbestos Insulators | \$31.82 | | \$7.14 | \$9.35 | \$0.41 | \$0.00 | \$2.60 | \$0.00 | \$0.00 | \$0.00 | \$51.32 | \$67.23 |
| Apprentice | Percent | | | | | | | | | | | |
| 1st year | 46.67 | \$14.85 | \$7.14 | \$5.10 | \$0.41 | \$0.00 | \$2.60 | \$0.00 | \$0.00 | \$0.00 | \$30.10 | \$37.53 |
| 2nd year | 53.58 | \$17.05 | \$7.14 | \$6.65 | \$0.41 | \$0.00 | \$2.60 | \$0.00 | \$0.00 | \$0.00 | \$33.85 | \$42.37 |
| 3rd year | 58.30 | \$18.55 | \$7.14 | \$6.65 | \$0.41 | \$0.00 | \$2.60 | \$0.00 | \$0.00 | \$0.00 | \$35.35 | \$44.63 |
| 4th year | 63.01 | \$20.05 | \$7.14 | \$6.65 | \$0.41 | \$0.00 | \$2.60 | \$0.00 | \$0.00 | \$0.00 | \$36.85 | \$46.87 |

Special Calculation Note : No special calculations for this skilled craft wage rate are required at this time.

Ratio :

- 1 Journeymen to 1 Apprentice
- 2 Journeymen to 2 Apprentice
- 3 Journeymen to 3 Apprentice
- 3 Journeymen to 1 Apprentice there After

Jurisdiction (* denotes special jurisdictional note):

ADAMS, BROWN, BUTLER*, CLERMONT, HAMILTON, HIGHLAND, WARREN*

Special Jurisdictional Note : In Butler County:townships of Fairfield,Hanover,Liberty,Milford,Morgan,Oxford,Ripley,Ross,St.Clair,Union & Wayne. In Warren County: Townships of Deerfield,Hamilton,Harlan,Salem,Union & Washington

Details :

All work in connection with Asbestos Removal, Abatement, Encapsulation, Lead Abatement, Hazardous Materials and Fire Stopping which is performed by employees in the Mechanic or Apprentice Classification shall be covered under the terms of this Agreement.

Prevailing Wage Rate Skilled Crafts

Name of Union: Asbestos Local 207 OH

Change # : LCN01-2018fbLoc207OH

Craft : Asbestos Worker Effective Date : 08/23/2018 Last Posted : 08/23/2018

| | BHR | Fringe Benefit Payments | | | | | | Irrevocable Fund | | Total PWR | Overtime Rate |
|-----------------------|---------|-------------------------|---------|---------|--------|---------|--------|------------------|----------|-----------|---------------|
| | | H&W | Pension | App Tr. | Vac. | Annuity | Other | LECET (*) | MISC (*) | | |
| Classification | | | | | | | | | | | |
| Asbestos Abatement | \$25.50 | \$7.25 | \$6.45 | \$0.65 | \$0.00 | \$0.00 | \$0.07 | \$0.00 | \$0.00 | \$39.92 | \$52.67 |
| Trainee | \$16.50 | \$7.25 | \$1.50 | \$0.65 | \$0.00 | \$0.00 | \$0.07 | \$0.00 | \$0.00 | \$25.97 | \$34.22 |

Special Calculation Note :

Ratio :

3 Journeymen to 1 Trainee

Jurisdiction (* denotes special jurisdictional note) :

ADAMS, ASHLAND, ASHTABULA*, ATHENS, AUGLAIZE, BROWN, BUTLER*, CARROLL, CHAMPAIGN, CLARK, CLERMONT, CLINTON, COLUMBIANA, COSHOCTON, CRAWFORD, CUYAHOGA, DARKE, DELAWARE, FAIRFIELD, FAYETTE, FRANKLIN, GEAUGA, GREENE, GUERNSEY, HAMILTON, HARDIN, HARRISON, HIGHLAND, HOCKING, HOLMES, HURON, KNOX, LAKE, LICKING, LOGAN, LORAIN, MADISON, MAHONING, MARION, MEDINA, MIAMI, MONTGOMERY, MORGAN, MORROW, MUSKINGUM, NOBLE, PERRY, PICKAWAY, PORTAGE, PREBLE, RICHLAND, ROSS, SHELBY, STARK, SUMMIT, TRUMBULL, TUSCARAWAS, UNION, VINTON, WARREN*, WAYNE

Special Jurisdictional Note : Butler County:(townships of Fairfield,Hanover,Liberty,Milford,Morgan,Oxford,Ripley,Ross,StClair,Union & Wayne.) (Lemon & Madison) Warren County: (townships of: Deerfield, Hamilton, Harlan, Salem, Union & Washington). (Clear Creek, Franklin, Mossie, Turtle Creek & Wayney). Ashtabula County: (post offices & townships of Ashtabula, Austinburg, Geneva, Harperfield, Jefferson, Plymouth & Saybrook) (townships of Andover, Cherry Valley, Colbrook, Canneaut, Denmark, Dorset, East Orwell, Hartsgrove, Kingville, Lenox, Monroe,Morgan,New Lyme,North Kingsville, Orwell, Pierpoint, Richmond Rock Creek, Rome, Sheffield, Trumbull, Wayne, Williamsfield & Windsor) Erie County:(post offices & townships of Berlin, Berlin Heights,Birmingham,Florence ,Huron, Milan, Shinrock & Vermilion)

Details :

Asbestos & lead paint abatement including,but not limited to the removal or encapsulation of asbestos & lead paint,all work in conjunction with the preparation of the removal of same & all work in conjunction with the clean up after said removal.The removal of all insulation materials, whether they contain asbestos or not, from mechanical systems (pipes, boilers, ducts, flues, breaching, etc.) is recognized as being the exclusive work of the Asbestos Abatement Workers.

On all mechanical systems (pipes, boilers, ducts, flues, breaching, etc.) that are going to be demolished, the removal of all insulating materials whether they contain asbestos or not shall be the exclusive work of the Laborers.

An Abatement Journeyman is anyone who has more than 300 hours in the Asbestos Abatement field.

Prevailing Wage Rate Skilled Crafts

Name of Union: Boilermaker Local 105

Change # : LCN02-2013fbLoc 105

Craft : Boilermaker Effective Date : 10/01/2013 Last Posted : 09/25/2013

| | BHR | | Fringe Benefit Payments | | | | | Irrevocable Fund | | Total PWR | Overtime Rate | |
|-------------------|----------------|---------|-------------------------|---------|---------|--------|---------|------------------|-----------|-----------|---------------|----------|
| | | | H&W | Pension | App Tr. | Vac. | Annuity | Other | LECET (*) | | | MISC (*) |
| Classification | | | | | | | | | | | | |
| Boilermaker | \$35.26 | | \$7.07 | \$13.28 | \$0.89 | \$0.00 | \$3.00 | \$0.55 | \$0.00 | \$0.00 | \$60.05 | \$77.68 |
| Apprentice | Percent | | | | | | | | | | | |
| 1st 6 months | 70.03 | \$24.69 | \$7.07 | \$11.30 | \$0.89 | \$0.00 | \$2.10 | \$0.55 | \$0.00 | \$0.00 | \$46.60 | \$58.95 |
| 2nd 6 months | 75.02 | \$26.45 | \$7.07 | \$11.30 | \$0.89 | \$0.00 | \$2.25 | \$0.55 | \$0.00 | \$0.00 | \$48.51 | \$61.74 |
| 3rd 6 months | 80.00 | \$28.21 | \$7.07 | \$11.30 | \$0.89 | \$0.00 | \$2.40 | \$0.55 | \$0.00 | \$0.00 | \$50.42 | \$64.52 |
| 4th 6 months | 85.02 | \$29.98 | \$7.07 | \$11.30 | \$0.89 | \$0.00 | \$2.55 | \$0.55 | \$0.00 | \$0.00 | \$52.34 | \$67.33 |
| 5th 6 months | 87.52 | \$30.86 | \$7.07 | \$13.28 | \$0.89 | \$0.00 | \$2.63 | \$0.55 | \$0.00 | \$0.00 | \$55.28 | \$70.71 |
| 6th 6 months | 90.03 | \$31.74 | \$7.07 | \$13.28 | \$0.89 | \$0.00 | \$2.70 | \$0.55 | \$0.00 | \$0.00 | \$56.23 | \$72.11 |
| 7th 6 months | 92.50 | \$32.62 | \$7.07 | \$13.28 | \$0.89 | \$0.00 | \$2.78 | \$0.55 | \$0.00 | \$0.00 | \$57.19 | \$73.49 |
| 8th 6 months | 95.00 | \$33.50 | \$7.07 | \$13.28 | \$0.89 | \$0.00 | \$2.85 | \$0.55 | \$0.00 | \$0.00 | \$58.14 | \$74.89 |

Special Calculation Note : Other is Supplemental Health and Welfare

Ratio :

5 Journeymen to 1 Apprentice

Jurisdiction (* denotes special jurisdictional note) :

ADAMS, ATHENS, BROWN, BUTLER,
CHAMPAIGN, CLARK, CLERMONT, CLINTON,
FAIRFIELD, FAYETTE, FRANKLIN, GALLIA,
GREENE, GUERNSEY, HAMILTON, HIGHLAND,
HOCKING, JACKSON, LAWRENCE, LICKING,
MADISON, MEIGS, MIAMI, MONTGOMERY,
MORGAN, MUSKINGUM, NOBLE, PERRY,
PICKAWAY, PIKE, PREBLE, ROSS, SCIOTO,
VINTON, WARREN

Special Jurisdictional Note :

Details :

Prevailing Wage Rate Skilled Crafts

Name of Union: Boilermaker Local 154

Change # : LCN01-2012kpLoc 154

Craft : Boilermaker Effective Date : 03/22/2012 Last Posted : 03/22/2012

| | BHR | | Fringe Benefit Payments | | | | | | Irrevocable Fund | | Total PWR | Overtime Rate |
|---|----------------|---------|-------------------------|---------|---------|--------|---------|--------|------------------|----------|-----------|---------------|
| | | | H&W | Pension | App Tr. | Vac. | Annuity | Other | LECET (*) | MISC (*) | | |
| Classification | | | | | | | | | | | | |
| Boilermaker | \$36.17 | | \$8.57 | \$11.28 | \$0.55 | \$0.00 | \$4.25 | \$0.34 | \$0.00 | \$1.40 | \$62.56 | \$80.65 |
| Trainee 60% | \$23.25 | | \$8.57 | \$3.59 | \$0.55 | \$0.00 | \$4.25 | \$0.34 | \$0.00 | \$1.40 | \$41.95 | \$53.57 |
| Trainee 70% | \$27.13 | | \$8.57 | \$3.59 | \$0.55 | \$0.00 | \$4.25 | \$0.34 | \$0.00 | \$1.40 | \$45.83 | \$59.40 |
| Trainee 80% | \$31.00 | | \$8.57 | \$3.59 | \$0.55 | \$0.00 | \$4.25 | \$0.34 | \$0.00 | \$1.40 | \$49.70 | \$65.20 |
| Trainee 90% | \$34.88 | | \$8.57 | \$3.59 | \$0.55 | \$0.00 | \$4.25 | \$0.34 | \$0.00 | \$1.40 | \$53.58 | \$71.02 |
| Apprentice Registered After 11/01/2005 | Percent | | | | | | | | | | | |
| 1st 6 months | 60.00 | \$21.70 | \$8.57 | \$3.59 | \$0.55 | \$0.00 | \$4.25 | \$0.34 | \$0.00 | \$1.40 | \$40.40 | \$51.25 |
| 2nd 6 months | 65.00 | \$23.51 | \$8.57 | \$3.59 | \$0.55 | \$0.00 | \$4.25 | \$0.34 | \$0.00 | \$1.40 | \$42.21 | \$53.97 |
| 3rd 6 months | 70.00 | \$25.32 | \$8.57 | \$3.59 | \$0.55 | \$0.00 | \$4.25 | \$0.34 | \$0.00 | \$1.40 | \$44.02 | \$56.68 |
| 4th 6 months | 75.00 | \$27.13 | \$8.57 | \$3.59 | \$0.55 | \$0.00 | \$4.25 | \$0.34 | \$0.00 | \$1.40 | \$45.83 | \$59.39 |
| 5th 6 months | 80.00 | \$28.94 | \$8.57 | \$3.59 | \$0.55 | \$0.00 | \$4.25 | \$0.34 | \$0.00 | \$1.40 | \$47.64 | \$62.10 |
| 6th 6 months | 85.00 | \$30.74 | \$8.57 | \$3.59 | \$0.55 | \$0.00 | \$4.25 | \$0.34 | \$0.00 | \$1.40 | \$49.44 | \$64.82 |
| 7th 6 months | 90.00 | \$32.55 | \$8.57 | \$3.59 | \$0.55 | \$0.00 | \$4.25 | \$0.34 | \$0.00 | \$1.40 | \$51.25 | \$67.53 |
| 8th 6 months | 95.00 | \$34.36 | \$8.57 | \$3.59 | \$0.55 | \$0.00 | \$4.25 | \$0.34 | \$0.00 | \$1.40 | \$53.06 | \$70.24 |

Special Calculation Note : No special calculations for this skilled craft wage rate are required at this time.

Ratio :
5 Journeymen to 1 Apprentice

Jurisdiction (* denotes special jurisdictional note) :
BUTLER, COLUMBIANA, FAYETTE, JEFFERSON,
LAWRENCE, MERCER, WARREN, WASHINGTON

Special Jurisdictional Note :

Details :

Work includes but not limited to: boiler making, acetylene burning, riveting, chipping, caulking, rigging, fitting-up, grinding, reaming, impact machine operating, unloading, and handling of boilermaker's material and equipment. Boilermakers, Blacksmiths, Forgers, Iron Shipbuilders

Prevailing Wage Rate Skilled Crafts

Name of Union: Bricklayer Local 18

Change # : LCN01-2021fbLoc18

Craft : Bricklayer Effective Date : 06/01/2021 Last Posted : 05/26/2021

| | BHR | | Fringe Benefit Payments | | | | | Irrevocable Fund | | Total PWR | Overtime Rate | |
|---------------------------|----------------|---------|-------------------------|---------|---------|--------|---------|------------------|-----------|-----------|---------------|----------|
| | | | H&W | Pension | App Tr. | Vac. | Annuity | Other | LECET (*) | | | MISC (*) |
| Classification | | | | | | | | | | | | |
| Bricklayer | \$30.87 | | \$9.45 | \$5.79 | \$0.63 | \$0.00 | \$0.00 | \$0.00 | \$0.00 | \$0.00 | \$46.74 | \$62.17 |
| Stone Mason | \$30.87 | | \$9.45 | \$5.79 | \$0.63 | \$0.00 | \$0.00 | \$0.00 | \$0.00 | \$0.00 | \$46.74 | \$62.17 |
| Pointer Caulker Cleaner | \$30.87 | | \$9.45 | \$5.79 | \$0.63 | \$0.00 | \$0.00 | \$0.00 | \$0.00 | \$0.00 | \$46.74 | \$62.17 |
| Refractory Workers | \$31.87 | | \$9.45 | \$5.79 | \$0.63 | \$0.00 | \$0.00 | \$0.00 | \$0.00 | \$0.00 | \$47.74 | \$63.67 |
| Refractory Worker Hot Pay | \$33.87 | | \$9.45 | \$5.79 | \$0.63 | \$0.00 | \$0.00 | \$0.00 | \$0.00 | \$0.00 | \$49.74 | \$66.67 |
| Sawman | \$31.12 | | \$9.45 | \$5.79 | \$0.63 | \$0.00 | \$0.00 | \$0.00 | \$0.00 | \$0.00 | \$46.99 | \$62.55 |
| Layout Man | \$31.12 | | \$9.45 | \$5.79 | \$0.63 | \$0.00 | \$0.00 | \$0.00 | \$0.00 | \$0.00 | \$46.99 | \$62.55 |
| Free Standing Chimney | \$31.37 | | \$9.45 | \$5.79 | \$0.63 | \$0.00 | \$0.00 | \$0.00 | \$0.00 | \$0.00 | \$47.24 | \$62.92 |
| Apprentice | Percent | | | | | | | | | | | |
| 1st 6 months | 60.00 | \$18.52 | \$9.45 | \$5.79 | \$0.63 | \$0.00 | \$0.00 | \$0.00 | \$0.00 | \$0.00 | \$34.39 | \$43.65 |
| 2nd 6 months | 65.00 | \$20.07 | \$9.45 | \$5.79 | \$0.63 | \$0.00 | \$0.00 | \$0.00 | \$0.00 | \$0.00 | \$35.94 | \$45.97 |
| 3rd 6 months | 70.00 | \$21.61 | \$9.45 | \$5.79 | \$0.63 | \$0.00 | \$0.00 | \$0.00 | \$0.00 | \$0.00 | \$37.48 | \$48.28 |
| 4th 6 months | 75.00 | \$23.15 | \$9.45 | \$5.79 | \$0.63 | \$0.00 | \$0.00 | \$0.00 | \$0.00 | \$0.00 | \$39.02 | \$50.60 |
| 5th 6 months | 80.00 | \$24.70 | \$9.45 | \$5.79 | \$0.63 | \$0.00 | \$0.00 | \$0.00 | \$0.00 | \$0.00 | \$40.57 | \$52.91 |
| 6th 6 months | 85.00 | \$26.24 | \$9.45 | \$5.79 | \$0.63 | \$0.00 | \$0.00 | \$0.00 | \$0.00 | \$0.00 | \$42.11 | \$55.23 |
| 7th 6 months | 90.00 | \$27.78 | \$9.45 | \$5.79 | \$0.63 | \$0.00 | \$0.00 | \$0.00 | \$0.00 | \$0.00 | \$43.65 | \$57.54 |
| 8th 6 months | 95.00 | \$29.33 | \$9.45 | \$5.79 | \$0.63 | \$0.00 | \$0.00 | \$0.00 | \$0.00 | \$0.00 | \$45.20 | \$59.86 |

| | | | | | | | | | | | | |
|-----------------------------------|-------|---------|--------|--------|--------|--------|--------|--------|--------|--------|---------|---------|
| MASON FINISHER 1st 180 Days | 45.00 | \$13.89 | \$0.00 | \$0.00 | \$0.00 | \$0.00 | \$0.00 | \$0.00 | \$0.00 | \$0.00 | \$13.89 | \$20.84 |
| 1st Year H&W after 6 months | 45.00 | \$13.89 | \$9.45 | \$0.00 | \$0.00 | \$0.00 | \$0.00 | \$0.00 | \$0.00 | \$0.00 | \$23.34 | \$30.29 |
| 2nd Year | 50.00 | \$15.44 | \$9.45 | \$0.00 | \$0.00 | \$0.00 | \$0.00 | \$0.00 | \$0.00 | \$0.00 | \$24.88 | \$32.60 |

Special Calculation Note : **In order to utilize a Pre-Apprentice, you must have 1 Registered Apprentice in your employ.

Ratio :

- 1-2 Journeyman to 1 Apprentice
- 3-4 Journeyman to 2 Apprentice
- 5-6 Journeyman to 2 Apprentice
- 7-10 Journeyman to 3 Apprentice

- 1 Apprentice permits 1 Mason Trainee
- 2 Apprentice permits 1 Mason Trainee
- 3 Apprentice permits 2 Mason Trainees
- 4 Apprentice permits 2 Mason Trainees

For each additional 5 Journeyman to 1 Apprentice,
for every 3 additional Apprentices, 1 Mason Finisher
may be added

Special Jurisdictional Note : In Preble County the following townships are included: (Dixon, Gasper, Graits, Israel, Lanier and Somers)

Details :

MASON FINISHER:duties shall be to work in all aspects of Masonry construction taking direction from the employer and the Journeyman Bricklayer & Stone Mason's working on the job. Mason Finisher's may work on job site only when a registered apprentice is on job and the ratios in table above will strictly be enforced.

Refractory work is classified as working with any of the following materials:
Acid brick, carbon black brick or carbon black block, firebrick grinding, plastics (with a gun)
and any resinous cement.

Fifty cents (\$0.50) per hour above scale shall be paid to employees working on free standing industrial or institutional chimneys which are completely detached from any building structure.

Prevailing Wage Rate Skilled Crafts

Name of Union: Bricklayer Local 18 Tile Finisher

Change # : LCN01-2019fbLoc18

Craft : Bricklayer Effective Date : 09/04/2019 Last Posted : 09/04/2019

| | BHR | | Fringe Benefit Payments | | | | | Irrevocable Fund | | Total PWR | Overtime Rate | |
|---|---------|---------|-------------------------|---------|---------|--------|---------|------------------|-----------|-----------|---------------|----------|
| | | | H&W | Pension | App Tr. | Vac. | Annuity | Other | LECET (*) | | | MISC (*) |
| Classification | | | | | | | | | | | | |
| Bricklayer Tile Marble Terrazzo Finisher | \$24.69 | | \$9.22 | \$5.10 | \$0.50 | \$0.00 | \$0.00 | \$0.00 | \$0.00 | \$0.00 | \$39.51 | \$51.86 |
| Terrazzo Base Grinder | \$25.19 | | \$9.22 | \$5.10 | \$0.50 | \$0.00 | \$0.00 | \$0.00 | \$0.00 | \$0.00 | \$40.01 | \$52.61 |
| Marble Sander Polisher | \$24.79 | | \$9.22 | \$5.10 | \$0.50 | \$0.00 | \$0.00 | \$0.00 | \$0.00 | \$0.00 | \$39.61 | \$52.01 |
| Apprentices | Percent | | | | | | | | | | | |
| 1st 6 months 0-600 hrs | 60.00 | \$14.81 | \$9.22 | \$5.10 | \$0.50 | \$0.00 | \$0.00 | \$0.00 | \$0.00 | \$0.00 | \$29.63 | \$37.04 |
| 2nd 6 months 601-1200 hrs | 65.00 | \$16.05 | \$9.22 | \$5.10 | \$0.50 | \$0.00 | \$0.00 | \$0.00 | \$0.00 | \$0.00 | \$30.87 | \$38.89 |
| 3rd 6 months 1201-1800 hrs | 70.00 | \$17.28 | \$9.22 | \$5.10 | \$0.50 | \$0.00 | \$0.00 | \$0.00 | \$0.00 | \$0.00 | \$32.10 | \$40.74 |
| 4th 6 months 1801-2400 hrs | 75.00 | \$18.52 | \$9.22 | \$5.10 | \$0.50 | \$0.00 | \$0.00 | \$0.00 | \$0.00 | \$0.00 | \$33.34 | \$42.60 |
| 5th 6 months 2401-3000 hrs | 80.00 | \$19.75 | \$9.22 | \$5.10 | \$0.50 | \$0.00 | \$0.00 | \$0.00 | \$0.00 | \$0.00 | \$34.57 | \$44.45 |
| 6th 6 months 3001-3600 | 90.00 | \$22.22 | \$9.22 | \$5.10 | \$0.50 | \$0.00 | \$0.00 | \$0.00 | \$0.00 | \$0.00 | \$37.04 | \$48.15 |
| 1-30 Days Prior to Entering Apprenticeship | 50.00 | \$12.35 | \$0.00 | \$0.00 | \$0.00 | \$0.00 | \$0.00 | \$0.00 | \$0.00 | \$0.00 | \$12.35 | \$18.52 |

Special Calculation Note : Classification title contains "Bricklayer" because contract originates within the Bricklayer Local.

Note that the classification description is clarified after the local union number at the top of the page. **In order to utilize a Pre-Apprentice, you must have 1 Registered Apprentice in your employ.**

Ratio :

- 1 Journeyman to 1 Apprentice
- 5 Journeymen to 1 Apprentice
- 10 Journeymen to 2 Apprentices
- 15 Journeymen to 3 Apprentices
- 20 Journeymen to 4 Apprentices
- 25 Journeymen to 5 Apprentices

Jurisdiction (* denotes special jurisdictional note) :

- ADAMS, BROWN, BUTLER, CLERMONT, GALLIA,
- HAMILTON, LAWRENCE, PREBLE*, SCIOTO,
- WARREN, WARREN*

Special Jurisdictional Note : Warren in the townships of Dixon, Gasper, Isrsel, Somers & Gratis in Prebble County

Details :

Prevailing Wage Rate Skilled Crafts

Name of Union: Bricklayer Local 18 Tile Mechanic

Change # : LCN01-2019fbLoc18

Craft : Bricklayer Effective Date : 09/04/2019 Last Posted : 09/04/2019

| | BHR | | Fringe Benefit Payments | | | | | Irrevocable Fund | | Total PWR | Overtime Rate | |
|--|---------|---------|-------------------------|---------|---------|--------|---------|------------------|-----------|-----------|---------------|----------|
| | | | H&W | Pension | App Tr. | Vac. | Annuity | Other | LECET (*) | | | MISC (*) |
| Classification | | | | | | | | | | | | |
| Bricklayer Tile Terrazzo Marble Mason Mechanic | \$29.24 | | \$9.22 | \$5.10 | \$0.54 | \$0.00 | \$0.00 | \$0.00 | \$0.00 | \$0.00 | \$44.10 | \$58.72 |
| Marble Layout Work | \$29.74 | | \$9.22 | \$5.10 | \$0.54 | \$0.00 | \$0.00 | \$0.00 | \$0.00 | \$0.00 | \$44.60 | \$59.47 |
| Swing Scaffold Worker | \$30.74 | | \$9.22 | \$5.10 | \$0.54 | \$0.00 | \$0.00 | \$0.00 | \$0.00 | \$0.00 | \$45.60 | \$60.97 |
| Apprentice after 2 years (2400 hrs) as Apprentice Finisher | | | | | | | | | | | | |
| 5th/6 Months 0-600 hrs. | 70.00 | \$20.47 | \$9.22 | \$5.10 | \$0.54 | \$0.00 | \$0.00 | \$0.00 | \$0.00 | \$0.00 | \$35.33 | \$45.56 |
| 6th/6 months 601-1200 hrs. | 75.00 | \$21.93 | \$9.22 | \$5.10 | \$0.54 | \$0.00 | \$0.00 | \$0.00 | \$0.00 | \$0.00 | \$36.79 | \$47.75 |
| 7th/6 months 1201-1800 hrs. | 80.00 | \$23.39 | \$9.22 | \$5.10 | \$0.54 | \$0.00 | \$0.00 | \$0.00 | \$0.00 | \$0.00 | \$38.25 | \$49.95 |
| 8th/6 months 1801-2400 hrs. | 90.00 | \$26.32 | \$9.22 | \$5.10 | \$0.54 | \$0.00 | \$0.00 | \$0.00 | \$0.00 | \$0.00 | \$41.18 | \$54.33 |

Special Calculation Note : Classification title contains "Bricklayer" because contract originates within the Bricklayer Local. Note that the classification description is clarified after the local union number at the top of the page.

Ratio :

- 1 Journeyman to 1 Apprentice
- 5 Journeymen to 1 Apprentice
- 10 Journeymen to 2 Apprentices
- 15 Journeymen to 3 Apprentices
- 20 Journeymen to 4 Apprentices
- 25 Journeymen to 5 Apprentices

Jurisdiction (* denotes special jurisdictional note) :

- ADAMS, BROWN, BUTLER, CLERMONT, GALLIA,
- HAMILTON, LAWRENCE, PREBLE*, SCIOTO, WARREN

Special Jurisdictional Note : In Preble County the Townships of Dixon, Israel, Gasper, Lanier, Somers and Gratis.

Details :

In order to utilize a Pre-Apprentice, you must have 1 Registered Apprentice in your employ.

Prevailing Wage Rate Skilled Crafts

Name of Union: Carpenter & Pile Driver SW District HevHwy

Change # : LCN01-2021fbLoc126

Craft : Carpenter Effective Date : 06/17/2021 Last Posted : 06/17/2021

| | BHR | | Fringe Benefit Payments | | | | | | Irrevocable Fund | | Total PWR | Overtime Rate |
|-----------------------|----------------|---------|-------------------------|---------|---------|--------|---------|--------|------------------|----------|-----------|---------------|
| | | | H&W | Pension | App Tr. | Vac. | Annuity | Other | LECET (*) | MISC (*) | | |
| Classification | | | | | | | | | | | | |
| Carpenter | \$31.62 | | \$8.09 | \$6.95 | \$0.40 | \$0.00 | \$3.30 | \$0.13 | \$0.00 | \$0.00 | \$50.49 | \$66.30 |
| Pile Driver | \$29.34 | | \$6.63 | \$6.95 | \$0.40 | \$0.00 | \$1.97 | \$0.10 | \$0.00 | \$0.00 | \$45.39 | \$60.06 |
| Apprentice: | Percent | | | | | | | | | | | |
| 1st 6 Months | 60.00 | \$18.97 | \$8.09 | \$6.95 | \$0.40 | \$0.00 | \$3.30 | \$0.13 | \$0.00 | \$0.00 | \$37.84 | \$47.33 |
| 2nd 6 Months | 65.00 | \$20.55 | \$8.09 | \$6.95 | \$0.40 | \$0.00 | \$3.30 | \$0.13 | \$0.00 | \$0.00 | \$39.42 | \$49.70 |
| 3rd 6 Months | 70.00 | \$22.13 | \$8.09 | \$6.95 | \$0.40 | \$0.00 | \$3.30 | \$0.13 | \$0.00 | \$0.00 | \$41.00 | \$52.07 |
| 4th 6 Months | 75.00 | \$23.71 | \$8.09 | \$6.95 | \$0.40 | \$0.00 | \$3.30 | \$0.13 | \$0.00 | \$0.00 | \$42.59 | \$54.44 |
| 5th 6 Months | 80.00 | \$25.30 | \$8.09 | \$6.95 | \$0.40 | \$0.00 | \$3.30 | \$0.13 | \$0.00 | \$0.00 | \$44.17 | \$56.81 |
| 6th 6 Months | 85.00 | \$26.88 | \$8.09 | \$6.95 | \$0.40 | \$0.00 | \$3.30 | \$0.13 | \$0.00 | \$0.00 | \$45.75 | \$59.19 |
| 7th 6 Months | 90.00 | \$28.46 | \$8.09 | \$6.95 | \$0.40 | \$0.00 | \$3.30 | \$0.13 | \$0.00 | \$0.00 | \$47.33 | \$61.56 |
| 8th 6 Months | 95.00 | \$30.04 | \$8.09 | \$6.95 | \$0.40 | \$0.00 | \$3.30 | \$0.13 | \$0.00 | \$0.00 | \$48.91 | \$63.93 |

Special Calculation Note : Other is UBC National Fund.

Ratio :

1 Journeymen to 1 Apprentice

An employer shall have the right to employ one (1) Apprentice for one (1) Journeyman Carpenter in its employment for the first Apprentice employed, and 1 (1) Apprentice for two (2) Journeyman Carpenter for additional Apprentices employed.

Thereafter, every third additional carpenter hired shall be an apprentice, if available, and if practical for the type of work being performed.

Jurisdiction (* denotes special jurisdictional note) :

BROWN, BUTLER, CHAMPAIGN, CLARK, CLERMONT, CLINTON, DARKE, GREENE, HAMILTON, LOGAN, MIAMI, MONTGOMERY, PREBLE, SHELBY, WARREN

Special Jurisdictional Note :

Details :

Highway Construction, Airport Construction, Heavy Construction but not limited to:(tunnels,subways,drainage projects,flood control,reservoirs). Railroad Construction,Sewer Waterworks & Utility Construction but not limited to: (storm sewers, waterlines, gaslines). Industrial & Building Site, Power Plant, Amusement Park, Athletic Stadium Site, Sewer and Water Plants.

When the Contractor furnishes the necessary underwater gear for the Diver, the Diver shall be paid one and one half (1&1/2) times the journeyman rate for the time spent in the water.

Prevailing Wage Rate Skilled Crafts

Name of Union: Carpenter & Pile Driver
SW Zone 2

Change # : LCN01-2021fbLoc126

Craft : Carpenter Effective Date : 07/14/2021 Last Posted : 07/14/2021

| | BHR | | Fringe Benefit Payments | | | | | Irrevocable Fund | | Total PWR | Overtime Rate | |
|----------------|---------|---------|-------------------------|---------|---------|--------|---------|------------------|-----------|-----------|---------------|----------|
| | | | H&W | Pension | App Tr. | Vac. | Annuity | Other | LECET (*) | | | MISC (*) |
| Classification | | | | | | | | | | | | |
| Carpenter | \$28.67 | | \$7.88 | \$6.95 | \$0.43 | \$0.00 | \$1.91 | \$0.13 | \$0.00 | \$0.00 | \$45.97 | \$60.31 |
| Pile Driver | \$25.84 | | \$6.62 | \$6.95 | \$0.40 | \$0.00 | \$0.91 | \$0.10 | \$0.00 | \$0.00 | \$40.82 | \$53.74 |
| Apprentice | Percent | | | | | | | | | | | |
| 1st 3 Months | 60.00 | \$17.20 | \$0.00 | \$0.00 | \$0.00 | \$0.00 | \$0.00 | \$0.00 | \$0.00 | \$0.00 | \$17.20 | \$25.80 |
| 2nd 3 Months | 60.00 | \$17.20 | \$7.88 | \$0.00 | \$0.43 | \$0.00 | \$1.91 | \$0.13 | \$0.00 | \$0.00 | \$27.55 | \$36.15 |
| 2rd 6 Months | 60.00 | \$17.20 | \$7.88 | \$0.00 | \$0.43 | \$0.00 | \$1.91 | \$0.13 | \$0.00 | \$0.00 | \$27.55 | \$36.15 |
| 3rd 6 Months | 65.00 | \$18.64 | \$7.88 | \$0.00 | \$0.43 | \$0.00 | \$1.91 | \$0.13 | \$0.00 | \$0.00 | \$28.99 | \$38.30 |
| 4th 6 Months | 65.00 | \$18.64 | \$7.88 | \$0.00 | \$0.43 | \$0.00 | \$1.91 | \$0.13 | \$0.00 | \$0.00 | \$28.99 | \$38.30 |
| 5th 6 Months | 70.00 | \$20.07 | \$7.88 | \$6.95 | \$0.43 | \$0.00 | \$1.91 | \$0.13 | \$0.00 | \$0.00 | \$37.37 | \$47.40 |
| 6th 6 Months | 75.00 | \$21.50 | \$7.88 | \$6.95 | \$0.43 | \$0.00 | \$1.91 | \$0.13 | \$0.00 | \$0.00 | \$38.80 | \$49.55 |
| 7th 6 Months | 80.00 | \$22.94 | \$7.88 | \$6.95 | \$0.43 | \$0.00 | \$1.91 | \$0.13 | \$0.00 | \$0.00 | \$40.24 | \$51.70 |
| 8th 6 Months | 85.00 | \$24.37 | \$7.88 | \$6.95 | \$0.43 | \$0.00 | \$1.91 | \$0.13 | \$0.00 | \$0.00 | \$41.67 | \$53.85 |

Special Calculation Note : Other is for UBC National Fund.

Ratio :

After employing 1 Journeymen, the next carpenter employed may be an Apprentice. After the first apprentice is employed, the ratio of Apprentice to Journeymen shall not exceed 2 Journeymen for 1 Apprentice.

Jurisdiction (* denotes special jurisdictional note) :

BROWN, BUTLER, CLERMONT, CLINTON, HAMILTON, WARREN

Special Jurisdictional Note :

Details :

Carpenter duties shall include but not limited to: Pile driving, milling, fashioning, joining, assembling, erecting, fastening, or dismantling of all material of wood, plastic, metal, fiber, cork, and composition, and all other substitute materials: pile driving, cutting, fitting, and placing of lagging, and the handling, cleaning, erecting, installing, and dismantling of machinery, equipment, and erecting pre-engineered metal buildings.

Pile Drivers work but not limited to: unloading, assembling, erection, repairs, operation, signaling, dismantling, and reloading all equipment that is used for pile driving including pile butts. pile butts is defined as sheeting or scrap piling. Underwater work that may be required in connection with the installation of piling. The diver and his tender work as a team and shall arrive at their own financial arrangements with the contractor. Any configuration of wood, steel, concrete, or composite that is jettied, driven, or vibrated onto the ground by conventional pile driving equipment for the purpose of supporting a future load that may be permanent or temporary.

Driving bracing, plumbing, cutting off and capping of all piling whether wood, metal, pipe piling or composite. loading, unloading, erecting, framing, dismantling, moving, and handling of pile driving equipment. piling used in the construction and repair of all wharves, docks, piers, trestles, caissons, cofferdams, and the erection of all sea walls and breakwaters. All underwater and marine work on bulkheads, wharves, docks, shipyards, caissons, piers, bridges, pipeline work, viaducts, marine cable and trestles, as well as salvage and reclamation work where divers are employed.

Rate shall include carpenters, acoustic, and ceiling installers, drywall installers, pile drivers, and floorlayers.

Prevailing Wage Rate Skilled Crafts

Name of Union: Carpenter Floorlayer SW District G

Change # : LCN01-2021sksLocSWDayton

Craft : Carpenter Effective Date : 10/06/2021 Last Posted : 10/06/2021

| | BHR | | Fringe Benefit Payments | | | | | Irrevocable Fund | | Total PWR | Overtime Rate | |
|----------------------|---------|---------|-------------------------|---------|---------|--------|---------|------------------|-----------|-----------|---------------|----------|
| | | | H&W | Pension | App Tr. | Vac. | Annuity | Other | LECET (*) | | | MISC (*) |
| Classification | | | | | | | | | | | | |
| Carpenter Floorlayer | \$27.12 | | \$7.93 | \$6.95 | \$0.43 | \$0.00 | \$1.95 | \$0.13 | \$0.00 | \$0.00 | \$44.51 | \$58.07 |
| Apprentice | Percent | | | | | | | | | | | |
| 1st 3 months | 65.00 | \$17.63 | \$0.00 | \$0.00 | \$0.00 | \$0.00 | \$0.00 | \$0.00 | \$0.00 | \$0.00 | \$17.63 | \$26.44 |
| 2nd 3 months | 65.00 | \$17.63 | \$7.93 | \$0.00 | \$0.43 | \$0.00 | \$1.95 | \$0.13 | \$0.00 | \$0.00 | \$28.07 | \$36.88 |
| 2nd 6 months | 65.00 | \$17.63 | \$7.93 | \$0.00 | \$0.43 | \$0.00 | \$1.95 | \$0.13 | \$0.00 | \$0.00 | \$28.07 | \$36.88 |
| 3rd 6 months | 70.00 | \$18.98 | \$7.93 | \$0.00 | \$0.43 | \$0.00 | \$1.95 | \$0.13 | \$0.00 | \$0.00 | \$29.42 | \$38.92 |
| 4th 6 months | 75.00 | \$20.34 | \$7.93 | \$0.00 | \$0.43 | \$0.00 | \$1.95 | \$0.13 | \$0.00 | \$0.00 | \$30.78 | \$40.95 |
| 5th 6 months | 80.00 | \$21.70 | \$7.93 | \$6.95 | \$0.43 | \$0.00 | \$1.95 | \$0.13 | \$0.00 | \$0.00 | \$39.09 | \$49.93 |
| 6th 6 months | 85.00 | \$23.05 | \$7.93 | \$6.95 | \$0.43 | \$0.00 | \$1.95 | \$0.13 | \$0.00 | \$0.00 | \$40.44 | \$51.97 |
| 7th 6 months | 90.00 | \$24.41 | \$7.93 | \$6.95 | \$0.43 | \$0.00 | \$1.95 | \$0.13 | \$0.00 | \$0.00 | \$41.80 | \$54.00 |
| 8th 6 months | 95.00 | \$25.76 | \$7.93 | \$6.95 | \$0.43 | \$0.00 | \$1.95 | \$0.13 | \$0.00 | \$0.00 | \$43.15 | \$56.04 |

Special Calculation Note : Other fs for UBC National Fund and Install

Ratio :

1 Journeymen to 1 Apprentice

Jurisdiction (* denotes special jurisdictional note) :

BROWN, BUTLER, CHAMPAIGN, CLARK, CLERMONT, CLINTON, DARKE, GREENE, HAMILTON, LOGAN, MIAMI, MONTGOMERY, PREBLE, SHELBY, WARREN

Special Jurisdictional Note :

Details :

Scope of work shall include, but not be limited to: receiving,unloading,handling,distribution and installation of all carpeting materials,carpet padding or matting materials and all resilient materials whether for use on walls,

floors, counter, sink, table and all preparation work necessary in connection therewith, including sanding work. the installation of nonstructural under-layment and the work of removing, cleaning waxing of any of the above. Carpeting shall include any floor covering composed of either natural or synthetic fibers that are made in breadths to be sewed, fastened or directly glued to floors or over cushioning sound-proofing materials. Resilient Floors shall consist of and include the laying of all special designs of wood, wood block, wood composition, cork, linoleum, asphalt, mastic, plastic, rubber tile, whether nailed or glued.

Prevailing Wage Rate Skilled Crafts

Name of Union: Carpenter Millwright Local 1090 SW Zone I

Change # : LCN01-2021sksLoc1066

Craft : Carpenter Effective Date : 09/22/2021 Last Posted : 09/22/2021

| | BHR | | Fringe Benefit Payments | | | | | Irrevocable Fund | | Total PWR | Overtime Rate | |
|----------------------|---------|---------|-------------------------|---------|---------|--------|---------|------------------|-----------|-----------|---------------|----------|
| | | | H&W | Pension | App Tr. | Vac. | Annuity | Other | LECET (*) | | | MISC (*) |
| Classification | | | | | | | | | | | | |
| Carpenter Millwright | \$31.68 | | \$7.93 | \$6.95 | \$0.49 | \$0.00 | \$6.94 | \$0.16 | \$0.00 | \$0.00 | \$54.15 | \$69.99 |
| Apprentice | Percent | | | | | | | | | | | |
| 1st 6 months | 60.00 | \$19.01 | \$7.93 | \$4.27 | \$0.49 | \$0.00 | \$4.16 | \$0.16 | \$0.00 | \$0.00 | \$36.02 | \$45.52 |
| 2nd 6 months | 65.00 | \$20.59 | \$7.93 | \$4.61 | \$0.49 | \$0.00 | \$4.51 | \$0.16 | \$0.00 | \$0.00 | \$38.29 | \$48.59 |
| 3rd 6 months | 70.00 | \$22.18 | \$7.93 | \$4.94 | \$0.49 | \$0.00 | \$4.86 | \$0.16 | \$0.00 | \$0.00 | \$40.56 | \$51.64 |
| 4th 6 months | 75.00 | \$23.76 | \$7.93 | \$5.28 | \$0.49 | \$0.00 | \$5.21 | \$0.16 | \$0.00 | \$0.00 | \$42.83 | \$54.71 |
| 5th 6 months | 80.00 | \$25.34 | \$7.93 | \$5.61 | \$0.49 | \$0.00 | \$5.55 | \$0.16 | \$0.00 | \$0.00 | \$45.08 | \$57.76 |
| 6th 6 months | 85.00 | \$26.93 | \$7.93 | \$5.95 | \$0.49 | \$0.00 | \$5.90 | \$0.16 | \$0.00 | \$0.00 | \$47.36 | \$60.82 |
| 7th 6 months | 90.00 | \$28.51 | \$7.93 | \$6.28 | \$0.49 | \$0.00 | \$6.25 | \$0.16 | \$0.00 | \$0.00 | \$49.62 | \$63.88 |
| 8th 6 months | 95.00 | \$30.10 | \$7.93 | \$6.62 | \$0.49 | \$0.00 | \$6.59 | \$0.16 | \$0.00 | \$0.00 | \$51.89 | \$66.93 |

Special Calculation Note : Other (\$0.16) \$0.11 National Fund and National Millwright Fund \$0.05

Ratio :

3 Journeymen to 1 Apprentice

Jurisdiction (* denotes special jurisdictional note) :

BROWN, BUTLER, CLERMONT, CLINTON, HAMILTON, WARREN

Special Jurisdictional Note :

Details :

Prevailing Wage Rate Skilled Crafts

Name of Union: Carpenter NE District Industrial Dock & Door

Change # : LCN01-2014fbCarpNEStatewide

Craft : Carpenter Effective Date : 03/05/2014 Last Posted : 03/05/2014

| | BHR | | Fringe Benefit Payments | | | | | Irrevocable Fund | | Total PWR | Overtime Rate |
|----------------|---------|---------|-------------------------|---------|---------|--------|---------|------------------|-----------|-----------|---------------|
| | | | H&W | Pension | App Tr. | Vac. | Annuity | Other | LECET (*) | | |
| Classification | | | | | | | | | | | |
| Carpenter | \$19.70 | \$5.05 | \$1.00 | \$0.15 | \$0.00 | \$0.00 | \$0.00 | \$0.00 | \$0.00 | \$25.90 | \$35.75 |
| Trainee | | Percent | | | | | | | | | |
| 1st Year | 60.00 | \$11.82 | \$5.05 | \$1.00 | \$0.15 | \$0.00 | \$0.00 | \$0.00 | \$0.00 | \$18.02 | \$23.93 |
| 2nd Year | 80.20 | \$15.80 | \$5.05 | \$1.00 | \$0.15 | \$0.00 | \$0.00 | \$0.00 | \$0.00 | \$22.00 | \$29.90 |

Special Calculation Note : No special calculations for this skilled craft wage rate are required at this time.

Ratio :

1 Journeymen to 1 Trainee

Jurisdiction (* denotes special jurisdictional note) :

ADAMS, ALLEN, ASHLAND, ASHTABULA, ATHENS, AUGLAIZE, BELMONT, BROWN, BUTLER, CARROLL, CHAMPAIGN, CLARK, CLERMONT, CLINTON, COLUMBIANA, COSHOCTON, CRAWFORD, CUYAHOGA, DARKE, DEFIANCE, DELAWARE, ERIE, FAIRFIELD, FAYETTE, FRANKLIN, FULTON, GALLIA, GEAUGA, GREENE, GUERNSEY, HAMILTON, HANCOCK, HARDIN, HARRISON, HENRY, HIGHLAND, HOCKING, HOLMES, HURON, JACKSON, JEFFERSON, KNOX, LAKE, LAWRENCE, LICKING, LOGAN, LORAIN, LUCAS, MADISON, MAHONING, MARION, MEDINA, MEIGS, MERCER, MIAMI, MONROE, MONTGOMERY, MORGAN, MORROW, MUSKINGUM, NOBLE, OTTAWA, PAULDING, PERRY, PICKAWAY, PIKE, PORTAGE, PREBLE, PUTNAM, RICHLAND, ROSS, SANDUSKY, SCIOTO, SENECA, SHELBY, STARK, SUMMIT, TRUMBULL, TUSCARAWAS, UNION, VAN WERT, VINTON, WARREN, WASHINGTON, WAYNE, WILLIAMS, WOOD, WYANDOT

Special Jurisdictional Note : Industrial Dock and Door is the installation of overhead doors, roll up doors and dock leveling equipment

Details :

10/27/10 New Contract jc

Prevailing Wage Rate Skilled Crafts

Name of Union: Cement Mason Bricklayer Local 97 HevHwy A

Change # : LCN01-2021fbHvyHwy

Craft : Bricklayer Effective Date : 06/01/2021 Last Posted : 05/26/2021

| | BHR | | Fringe Benefit Payments | | | | | Irrevocable Fund | | Total PWR | Overtime Rate | |
|---|---------|---------|-------------------------|---------|---------|--------|---------|------------------|-----------|-----------|---------------|----------|
| | | | H&W | Pension | App Tr. | Vac. | Annuity | Other | LECET (*) | | | MISC (*) |
| Classification | | | | | | | | | | | | |
| Cement Mason Bricklayer Sewer Water Works A | \$30.40 | | \$9.50 | \$7.57 | \$0.48 | \$0.00 | \$0.00 | \$0.00 | \$0.00 | \$0.00 | \$47.95 | \$63.15 |
| Apprentice | Percent | | | | | | | | | | | |
| 1st year | 50.00 | \$15.20 | \$9.50 | \$7.57 | \$0.48 | \$0.00 | \$0.00 | \$0.00 | \$0.00 | \$0.00 | \$32.75 | \$40.35 |
| 2nd year | 70.00 | \$21.28 | \$9.50 | \$7.57 | \$0.48 | \$0.00 | \$0.00 | \$0.00 | \$0.00 | \$0.00 | \$38.83 | \$49.47 |
| 3rd year | 90.00 | \$27.36 | \$9.50 | \$7.57 | \$0.48 | \$0.00 | \$0.00 | \$0.00 | \$0.00 | \$0.00 | \$44.91 | \$58.59 |

Special Calculation Note : NOT FOR BUILDING CONSTRUCTION.

Ratio :

- 3 Journeymen to 1 Apprentice
- 6 Journeymen to 2 Apprentice
- 9 Journeymen to 3 Apprentice
- 12 Journeymen to 4 Apprentice
- 15 Journeymen to 5 Apprentice

Jurisdiction (* denotes special jurisdictional note) :

ADAMS, ALLEN, ASHLAND, ASHTABULA, ATHENS, AUGLAIZE, BELMONT, BROWN, BUTLER, CARROLL, CHAMPAIGN, CLARK, CLERMONT, CLINTON, COLUMBIANA, COSHOCTON, CRAWFORD, CUYAHOGA, DARKE, DEFIANCE, DELAWARE, ERIE, FAIRFIELD, FAYETTE, FRANKLIN, FULTON, GALLIA, GEauga, GREENE, GUERNSEY, HAMILTON, HANCOCK, HARDIN, HARRISON, HENRY, HIGHLAND, HOCKING, HOLMES, HURON, JACKSON, JEFFERSON, KNOX, LAKE, LAWRENCE, LICKING, LOGAN, LORAIN, LUCAS, MADISON, MAHONING, MARION, MEDINA, MEIGS, MERCER, MIAMI, MONROE, MONTGOMERY, MORGAN, MORROW, MUSKINGUM, NOBLE, OTTAWA, PAULDING, PERRY, PICKAWAY, PIKE, PORTAGE, PREBLE, PUTNAM, RICHLAND, ROSS, SANDUSKY, SCIOTO, SENECA, SHELBY, STARK, SUMMIT, TRUMBULL, TUSCARAWAS, UNION, VAN WERT, VINTON, WARREN, WASHINGTON, WAYNE

Special Jurisdictional Note :

Details :

(A) Highway Construction, Sewer, Waterworks And Utility Construction, Industrial & Building Site Heavy Construction, Airport Construction Or Railroad Construction Work.

(B) Power Plant, Tunnels, Amusement Park, Athletic Stadium Site Work ,Pollution Control,Sewer Plant, Waste Plant, & Water Treatment Facilities, Construction.

Prevailing Wage Rate Skilled Crafts

Name of Union: Cement Mason Bricklayer Local 97 HevHwy B

Change # : LCN01-2021fbHvyHwy

Craft : Bricklayer Effective Date : 06/01/2021 Last Posted : 05/26/2021

| | BHR | | Fringe Benefit Payments | | | | | | Irrevocable Fund | | Total PWR | Overtime Rate |
|--|---------|---------|-------------------------|---------|---------|--------|---------|--------|------------------|----------|-----------|---------------|
| | | | H&W | Pension | App Tr. | Vac. | Annuity | Other | LECET (*) | MISC (*) | | |
| Classification | | | | | | | | | | | | |
| Cement Mason Bricklayer Power Plants Tunnels Amusement Parks B | \$31.39 | | \$9.50 | \$7.57 | \$0.49 | \$0.00 | \$0.00 | \$0.00 | \$0.00 | \$0.00 | \$48.95 | \$64.64 |
| Apprentice | Percent | | | | | | | | | | | |
| 1st year | 50.00 | \$15.70 | \$9.50 | \$7.57 | \$0.49 | \$0.00 | \$0.00 | \$0.00 | \$0.00 | \$0.00 | \$33.26 | \$41.10 |
| 2nd year | 70.00 | \$21.97 | \$9.50 | \$7.57 | \$0.49 | \$0.00 | \$0.00 | \$0.00 | \$0.00 | \$0.00 | \$39.53 | \$50.52 |
| 3rd year | 90.00 | \$28.25 | \$9.50 | \$7.57 | \$0.49 | \$0.00 | \$0.00 | \$0.00 | \$0.00 | \$0.00 | \$45.81 | \$59.94 |

Special Calculation Note : NOT FOR BUILDING CONSTRUCTION.

Ratio :

- 3 Journeymen to 1 Apprentice
- 6 Journeymen to 2 Apprentice
- 9 Journeymen to 2 Apprentice
- 12 Journeymen to 4 Apprentice
- 15 Journeymen to 5 Apprentice

Jurisdiction (* denotes special jurisdictional note) :

ADAMS, ALLEN, ASHLAND, ASHTABULA, ATHENS, AUGLAIZE, BELMONT, BROWN, BUTLER, CARROLL, CHAMPAIGN, CLARK, CLERMONT, CLINTON, COLUMBIANA, COSHOCTON, CRAWFORD, CUYAHOGA, DARKE, DEFIANCE, DELAWARE, ERIE, FAIRFIELD, FAYETTE, FRANKLIN, FULTON, GALLIA, GEAUGA, GREENE, GUERNSEY, HAMILTON, HANCOCK, HARDIN, HARRISON, HENRY, HIGHLAND, HOCKING, HOLMES, HURON, JACKSON, JEFFERSON, KNOX, LAKE, LAWRENCE, LICKING, LOGAN, LORAIN, LUCAS, MADISON, MAHONING, MARION, MEDINA, MEIGS, MERCER, MIAMI, MONROE, MONTGOMERY, MORGAN, MORROW, MUSKINGUM, NOBLE, OTTAWA, PAULDING, PERRY, PICKAWAY, PIKE, PORTAGE, PREBLE, PUTNAM, RICHLAND, ROSS, SANDUSKY, SCIOTO, SENECA, SHELBY, STARK, SUMMIT,

TRUMBULL, TUSCARAWAS, UNION, VAN WERT,
VINTON, WARREN, WASHINGTON, WAYNE

Special Jurisdictional Note :

Details :

(A) Highway Construction, Sewer, Waterworks And Utility Construction, Industrial & Building Site Heavy Construction, Airport Construction Or Railroad Construction Work.

(B) Power Plant, Tunnels, Amusement Park, Athletic Stadium Site Work ,Pollution Control,Sewer Plant, Waste Plant, & Water Treatment Facilities, Construction.

Prevailing Wage Rate Skilled Crafts

Name of Union: Cement Mason Local 132 (Cincinnati)

Change # : LCN01-2021fbLoc132

Craft : Cement Effective Date : 07/14/2021 Last Posted : 07/14/2021

| | BHR | | Fringe Benefit Payments | | | | | Irrevocable Fund | | Total PWR | Overtime Rate | |
|----------------|---------|---------|-------------------------|---------|---------|--------|---------|------------------|-----------|-----------|---------------|----------|
| | | | H&W | Pension | App Tr. | Vac. | Annuity | Other | LECET (*) | | | MISC (*) |
| Classification | | | | | | | | | | | | |
| Cement Mason | \$28.00 | | \$7.15 | \$6.50 | \$0.65 | \$0.00 | \$0.10 | \$0.00 | \$0.00 | \$0.00 | \$42.40 | \$56.40 |
| Apprentice | Percent | | | | | | | | | | | |
| 1st yr | 70.00 | \$19.60 | \$7.15 | \$6.50 | \$0.65 | \$0.00 | \$0.10 | \$0.00 | \$0.00 | \$0.00 | \$34.00 | \$43.80 |
| 2nd yr | 80.00 | \$22.40 | \$7.15 | \$6.50 | \$0.65 | \$0.00 | \$0.10 | \$0.00 | \$0.00 | \$0.00 | \$36.80 | \$48.00 |
| 3rd yr | 90.00 | \$25.20 | \$7.15 | \$6.50 | \$0.65 | \$0.00 | \$0.10 | \$0.00 | \$0.00 | \$0.00 | \$39.60 | \$52.20 |

Special Calculation Note : No special calculations for this skilled craft wage rate are required at this time.

Ratio :

- 1 Journeymen to 1 Apprentice
- 4 Journeymen to 2 Apprentice
- 7 Journeymen to 3 Apprentice
- 10 Journeymen to 4 Apprentice

Jurisdiction (* denotes special jurisdictional note) :

BROWN, BUTLER, CLERMONT, HAMILTON, HIGHLAND, WARREN

Special Jurisdictional Note :

Details :

- *Cement Masons working on silo & slip form work shall receive \$.50 per hour over Journeyman scale.
- *Cement Masons working on swinging scaffolds shall receive \$.50 per hour over Journeyman scale.
- *Cement Masons working on high lifts from 20' and above shall receive \$.50 per hour over Journeyman scale.

Prevailing Wage Rate Skilled Crafts

Name of Union: Cement Mason Statewide HevHwy Exhibit A District II

Change # : OCN01-2021fbCementHevHwy

Craft : Cement Mason Effective Date : 05/01/2021 Last Posted : 04/23/2021

| | BHR | | Fringe Benefit Payments | | | | | | Irrevocable Fund | | Total PWR | Overtime Rate |
|-----------------------|----------------|---------|-------------------------|---------|---------|--------|---------|--------|------------------|----------|-----------|---------------|
| | | | H&W | Pension | App Tr. | Vac. | Annuity | Other | LECET (*) | MISC (*) | | |
| Classification | | | | | | | | | | | | |
| Cement Mason | \$31.15 | | \$8.25 | \$7.35 | \$0.65 | \$0.00 | \$2.25 | \$0.07 | \$0.00 | \$0.00 | \$49.72 | \$65.29 |
| Apprentice | Percent | | | | | | | | | | | |
| 1st Year | 70.00 | \$21.80 | \$8.25 | \$7.35 | \$0.65 | \$0.00 | \$2.25 | \$0.07 | \$0.00 | \$0.00 | \$40.37 | \$51.28 |
| 2nd Year | 80.00 | \$24.92 | \$8.25 | \$7.35 | \$0.65 | \$0.00 | \$2.25 | \$0.07 | \$0.00 | \$0.00 | \$43.49 | \$55.95 |
| 3rd Year | 90.00 | \$28.03 | \$8.25 | \$7.35 | \$0.65 | \$0.00 | \$2.25 | \$0.07 | \$0.00 | \$0.00 | \$46.60 | \$60.62 |

Special Calculation Note : Other \$0.07 is for International Training Fund

Ratio :

1 Journeymen to 1 Apprentice
2 to 1 thereafter

Jurisdiction (* denotes special jurisdictional note) :

ALLEN, AUGLAIZE, BROWN, BUTLER, CARROLL, CLERMONT, COLUMBIANA, DEFIANCE, ERIE, HAMILTON, HARDIN, HIGHLAND, HOLMES, HURON, LOGAN, LORAIN, MAHONING, MEDINA, MERCER, OTTAWA, PAULDING, PORTAGE, SANDUSKY, SENECA, STARK, SUMMIT, TRUMBULL, TUSCARAWAS, VAN WERT, WARREN, WAYNE, WILLIAMS

Special Jurisdictional Note : (A) Highway Construction, Sewer, Waterworks And Utility Construction, Industrial & Building Site, Heavy Construction, Airport Construction Or Railroad Construction Work.

Details :

Prevailing Wage Rate Skilled Crafts

Name of Union: Cement Mason Statewide HevHwy Exhibit B District II

Change # : OCN01-2021fbCementHevHwy

Craft : Cement Mason Effective Date : 05/01/2021 Last Posted : 04/23/2021

| | BHR | | Fringe Benefit Payments | | | | | Irrevocable Fund | | Total PWR | Overtime Rate | |
|----------------|---------|---------|-------------------------|---------|---------|--------|---------|------------------|-----------|-----------|---------------|----------|
| | | | H&W | Pension | App Tr. | Vac. | Annuity | Other | LECET (*) | | | MISC (*) |
| Classification | | | | | | | | | | | | |
| Cement Mason | \$32.02 | | \$8.25 | \$7.35 | \$0.65 | \$0.00 | \$2.25 | \$0.07 | \$0.00 | \$0.00 | \$50.59 | \$66.60 |
| Apprentice | Percent | | | | | | | | | | | |
| 1st Year | 70.00 | \$22.41 | \$8.25 | \$7.35 | \$0.65 | \$0.00 | \$2.25 | \$0.07 | \$0.00 | \$0.00 | \$40.98 | \$52.19 |
| 2nd Year | 80.00 | \$25.62 | \$8.25 | \$7.35 | \$0.65 | \$0.00 | \$2.25 | \$0.07 | \$0.00 | \$0.00 | \$44.19 | \$56.99 |
| 3rd Year | 90.00 | \$28.82 | \$8.25 | \$7.35 | \$0.65 | \$0.00 | \$2.25 | \$0.07 | \$0.00 | \$0.00 | \$47.39 | \$61.80 |

Special Calculation Note : Other \$0.07 is for International Training Fund.

| | |
|---|--|
| <p>Ratio :</p> <p>1 Journeymen to 1 Apprentice 2 to 1 thereafter</p> | <p>Jurisdiction (* denotes special jurisdictional note) :</p> <p>ALLEN, AUGLAIZE, BROWN, BUTLER, CARROLL, CLERMONT, COLUMBIANA, DEFIANCE, ERIE, HAMILTON, HARDIN, HIGHLAND, HOLMES, HURON, LOGAN, LORAIN, MAHONING, MEDINA, MERCER, OTTAWA, PAULDING, PORTAGE, SANDUSKY, SENECA, STARK, SUMMIT, TRUMBULL, TUSCARAWAS, VAN WERT, WARREN, WAYNE, WILLIAMS</p> |
|---|--|

Special Jurisdictional Note : (B) Power Plant, Tunnels, Amusement Park, Athletic Stadium Site Work, Pollution Control, Sewer Plant, Waste Plant, & Water Treatment Facilities, Construction.

Details :

| | | | | | | | | | | | | |
|--------------|-------|---------|--------|--------|--------|--------|--------|--------|--------|--------|---------|---------|
| 1st 1000 hrs | 60.00 | \$27.57 | \$6.75 | \$0.82 | \$0.27 | \$0.00 | \$6.57 | \$0.60 | \$0.00 | \$0.00 | \$42.38 | \$56.06 |
| 2nd 1000 hrs | 65.00 | \$29.65 | \$6.75 | \$0.89 | \$0.30 | \$0.00 | \$7.12 | \$0.60 | \$0.00 | \$0.00 | \$45.31 | \$60.13 |
| 3rd 1000 hrs | 70.00 | \$31.93 | \$6.75 | \$0.96 | \$0.32 | \$0.00 | \$7.66 | \$0.60 | \$0.00 | \$0.00 | \$48.22 | \$64.18 |
| 4th 1000 hrs | 75.00 | \$34.21 | \$6.75 | \$1.03 | \$0.34 | \$0.00 | \$8.21 | \$0.60 | \$0.00 | \$0.00 | \$51.14 | \$68.24 |
| 5th 1000 hrs | 80.00 | \$36.49 | \$6.75 | \$1.09 | \$0.36 | \$0.00 | \$8.76 | \$0.60 | \$0.00 | \$0.00 | \$54.05 | \$72.29 |
| 6th 1000 hrs | 85.00 | \$38.77 | \$6.75 | \$1.16 | \$0.39 | \$0.00 | \$9.30 | \$0.60 | \$0.00 | \$0.00 | \$56.97 | \$76.35 |
| 7th 1000 hrs | 90.00 | \$41.05 | \$6.75 | \$1.23 | \$0.41 | \$0.00 | \$9.85 | \$0.60 | \$0.00 | \$0.00 | \$59.89 | \$80.41 |

Special Calculation Note : Other is Health Retirement Account

Operator "A"

John Henry Rock Drill, D-6 (or equivalent) and above, Trackhoe Digger, (320 Track excavator), Cranes (greater then 25 tons and less than 45 tons).

Operator "B"

Cranes (greater than 6 tons and up to 25 tons), Backhoes, Road Tractor, Dozer up to D-5, Pressure Digger-wheeled or tracked, all Tension wire Stringing equipment.

Operator "C"

Trench, Backhoe, Riding type vibratory Compactor, Ground Rod Driver, Boom Truck (6 ton & below), Skid Steer Loaders, Material Handler.

*All Operators of cranes 45 ton or larger shall be paid the journeyman rate of pay. \$0.30 is for Health Retirement Account.

Ratio :

1 Journeyman to 1 Apprentice

Jurisdiction (* denotes special jurisdictional note) :

ADAMS, ASHLAND, ASHTABULA, ATHENS, AUGLAIZE, BELMONT, BROWN, BUTLER, CARROLL, CHAMPAIGN, CLARK, CLERMONT, CLINTON, COLUMBIANA, COSHOCTON, CRAWFORD, CUYAHOGA, DARKE, DELAWARE, FAIRFIELD, FAYETTE, FRANKLIN, GALLIA, GEAUGA, GREENE, GUERNSEY, HAMILTON, HARRISON, HIGHLAND, HOCKING, HOLMES, JACKSON, JEFFERSON, KNOX, LAKE, LAWRENCE, LICKING, LOGAN, LORAIN, MADISON, MAHONING, MARION, MEDINA, MEIGS, MERCER, MIAMI, MONROE, MONTGOMERY, MORGAN, MORROW, MUSKINGUM, NOBLE, PERRY, PICKAWAY, PIKE, PORTAGE, PREBLE, RICHLAND, ROSS, SCIOTO, SHELBY, STARK, SUMMIT, TRUMBULL, TUSCARAWAS, UNION, VINTON, WARREN, WASHINGTON, WAYNE

Special Jurisdictional Note :

Details :

Heli - Arc Welding will be paid \$.30 above Journeyman rate. Additional compensation of 10% over the Journeyman

Prevailing Wage Rate Skilled Crafts

Name of Union: Electrical Local 71 Outside Cincinnati

Change # : LCN01-2021fbLoc71Cincinnati

Craft : Lineman Effective Date : 03/16/2021 Last Posted : 03/16/2021

| | BHR | | Fringe Benefit Payments | | | | | Irrevocable Fund | | Total PWR | Overtime Rate | |
|--------------------------------------|----------------|---------|-------------------------|---------|---------|--------|---------|------------------|-----------|-----------|---------------|----------|
| | | | H&W | Pension | App Tr. | Vac. | Annuity | Other | LECET (*) | | | MISC (*) |
| Classification | | | | | | | | | | | | |
| Electrical Lineman | \$40.31 | | \$6.75 | \$1.21 | \$0.40 | \$0.00 | \$7.66 | \$0.06 | \$0.00 | \$0.00 | \$56.39 | \$76.54 |
| Traffic Signal & Lighting Journeyman | \$38.77 | | \$6.75 | \$1.16 | \$0.39 | \$0.00 | \$7.37 | \$0.06 | \$0.00 | \$0.00 | \$54.50 | \$73.89 |
| Equipment Operator | \$35.41 | | \$6.75 | \$1.06 | \$0.35 | \$0.00 | \$6.73 | \$0.06 | \$0.00 | \$0.00 | \$50.36 | \$68.06 |
| Groundman 0-12 months (W/O CDL) | \$21.47 | | \$6.75 | \$0.64 | \$0.21 | \$0.00 | \$4.08 | \$0.06 | \$0.00 | \$0.00 | \$33.21 | \$43.95 |
| Groundman 0-21 Months (W/CDL) | \$23.46 | | \$6.75 | \$0.70 | \$0.23 | \$0.00 | \$4.46 | \$0.06 | \$0.00 | \$0.00 | \$35.66 | \$47.39 |
| Groundman 1 Year or More (W/CDL) | \$25.45 | | \$6.75 | \$0.76 | \$0.25 | \$0.00 | \$4.84 | \$0.06 | \$0.00 | \$0.00 | \$38.11 | \$50.83 |
| Traffic Signal Apprentices | | | | | | | | | | | | |
| 1st 1,000 hours | \$23.26 | | \$6.75 | \$0.70 | \$0.23 | \$0.00 | \$4.42 | \$0.06 | \$0.00 | \$0.00 | \$35.42 | \$47.05 |
| 2nd 1,000 hours | \$25.20 | | \$6.75 | \$0.76 | \$0.25 | \$0.00 | \$4.79 | \$0.06 | \$0.00 | \$0.00 | \$37.81 | \$50.41 |
| 3rd 1,000 hours | \$27.14 | | \$6.75 | \$0.81 | \$0.27 | \$0.00 | \$5.16 | \$0.06 | \$0.00 | \$0.00 | \$40.19 | \$53.76 |
| 4th 1,000 hours | \$29.08 | | \$6.75 | \$0.87 | \$0.29 | \$0.00 | \$5.53 | \$0.06 | \$0.00 | \$0.00 | \$42.58 | \$57.12 |
| 5th 1,000 hours | \$31.01 | | \$6.75 | \$0.93 | \$0.31 | \$0.00 | \$5.89 | \$0.06 | \$0.00 | \$0.00 | \$44.95 | \$60.46 |
| 6th 1,000 hours | \$34.89 | | \$6.75 | \$1.05 | \$0.35 | \$0.00 | \$6.63 | \$0.06 | \$0.00 | \$0.00 | \$49.73 | \$67.17 |
| Apprentice Lineman | Percent | | | | | | | | | | | |
| 1st 1,000 | 60.00 | \$24.19 | \$6.75 | \$0.73 | \$0.24 | \$0.00 | \$4.60 | \$0.06 | \$0.00 | \$0.00 | \$36.57 | \$48.66 |

| Hours | | | | | | | | | | | | |
|-----------------|-------|---------|--------|--------|--------|--------|--------|--------|--------|--------|---------|---------|
| 2nd 1,000 Hours | 65.00 | \$26.20 | \$6.75 | \$0.79 | \$0.26 | \$0.00 | \$4.98 | \$0.06 | \$0.00 | \$0.00 | \$39.04 | \$52.14 |
| 3rd 1,000 Hours | 70.00 | \$28.22 | \$6.75 | \$0.85 | \$0.28 | \$0.00 | \$5.36 | \$0.06 | \$0.00 | \$0.00 | \$41.52 | \$55.63 |
| 4th 1,000 Hours | 75.00 | \$30.23 | \$6.75 | \$0.91 | \$0.30 | \$0.00 | \$5.74 | \$0.06 | \$0.00 | \$0.00 | \$43.99 | \$59.11 |
| 5th 1,000 Hours | 80.00 | \$32.25 | \$6.75 | \$0.97 | \$0.32 | \$0.00 | \$6.13 | \$0.06 | \$0.00 | \$0.00 | \$46.48 | \$62.60 |
| 6th 1,000 Hours | 85.00 | \$34.26 | \$6.75 | \$1.03 | \$0.34 | \$0.00 | \$6.51 | \$0.06 | \$0.00 | \$0.00 | \$48.95 | \$66.09 |
| 7th 1,000 Hours | 90.00 | \$36.28 | \$6.75 | \$1.09 | \$0.36 | \$0.00 | \$6.89 | \$0.06 | \$0.00 | \$0.00 | \$51.43 | \$69.57 |

Special Calculation Note : Other is Safety & Education Fund.

Ratio : 1 Journeymen to 1 Apprentice

Jurisdiction (* denotes special jurisdictional note) : BROWN, BUTLER, CLERMONT, HAMILTON, WARREN

Special Jurisdictional Note :

Details :

A groundman when directed shall assist a Journeyman in the performance of his/her work on the ground, including the use of hand tools. A Groundman under no circumstances shall climb poles, towers, ladders, or work from an elevated platform or bucket truck.

No more than three (3) Groundmen shall work alone. Jobs with more than three Groundmen shall be supervised by a Groundcrew Foreman, Journeyman Lineman, Journeyman Traffic Signal Technician or an Equipment Operator.

Scope of Work: installation and maintenance of highway and street lighting, highway and street sign lighting, electronic message boards and traffic control systems, camera systems, traffic signal work, substation and line construction including overhead and underground projects for private and industrial work as in accordance with the IBEW Constitution. This Agreement includes the operation of all tools and equipment necessary for the installation of the above projects.

Prevailing Wage Rate

Skilled Crafts

Name of Union: Electrical Local 71 Outside Utility Power

Change # : LCN01-2021fbLoc7

Craft : Lineman Effective Date : 03/16/2021 Last Posted : 03/16/2021

| | BHR | | Fringe Benefit Payments | | | | | Irrevocable Fund | | Total PWR | Overtime Rate | |
|---------------------------------|----------------|---------|-------------------------|---------|---------|--------|---------|------------------|-----------|-----------|---------------|----------|
| | | | H&W | Pension | App Tr. | Vac. | Annuity | Other | LECET (*) | | | MISC (*) |
| Classification | | | | | | | | | | | | |
| Electrical Lineman | \$43.22 | | \$6.75 | \$1.30 | \$0.43 | \$0.00 | \$10.37 | \$0.60 | \$0.00 | \$0.00 | \$62.67 | \$84.28 |
| Substation Technician | \$43.22 | | \$6.75 | \$1.30 | \$0.43 | \$0.00 | \$10.37 | \$0.60 | \$0.00 | \$0.00 | \$62.67 | \$84.28 |
| Cable Splicer | \$45.26 | | \$6.75 | \$1.36 | \$0.45 | \$0.00 | \$10.86 | \$0.60 | \$0.00 | \$0.00 | \$65.28 | \$87.91 |
| Operator A | \$38.75 | | \$6.75 | \$1.16 | \$0.39 | \$0.00 | \$9.30 | \$0.60 | \$0.00 | \$0.00 | \$56.95 | \$76.32 |
| Operator B | \$34.27 | | \$6.75 | \$1.03 | \$0.34 | \$0.00 | \$8.22 | \$0.60 | \$0.00 | \$0.00 | \$51.21 | \$68.34 |
| Operator C | \$27.54 | | \$6.75 | \$0.83 | \$0.28 | \$0.00 | \$6.61 | \$0.60 | \$0.00 | \$0.00 | \$42.61 | \$56.38 |
| Groundman 0-12 months Exp | \$21.61 | | \$6.75 | \$0.65 | \$0.22 | \$0.00 | \$5.19 | \$0.60 | \$0.00 | \$0.00 | \$35.02 | \$45.82 |
| Groundman 0-12 months Exp w/CDL | \$23.77 | | \$6.75 | \$0.71 | \$0.24 | \$0.00 | \$5.70 | \$0.60 | \$0.00 | \$0.00 | \$37.77 | \$49.66 |
| Groundman 1 yr or more | \$23.77 | | \$6.75 | \$0.71 | \$0.24 | \$0.00 | \$5.70 | \$0.60 | \$0.00 | \$0.00 | \$37.77 | \$49.66 |
| Groundman 1 yr or more w/CDL | \$28.09 | | \$6.75 | \$0.84 | \$0.28 | \$0.00 | \$6.74 | \$0.60 | \$0.00 | \$0.00 | \$43.30 | \$57.35 |
| Equipment Mechanic A | \$34.27 | | \$6.75 | \$1.03 | \$0.34 | \$0.00 | \$8.22 | \$0.60 | \$0.00 | \$0.00 | \$51.21 | \$68.34 |
| Equipment Mechanic B | \$30.91 | | \$6.75 | \$0.93 | \$0.31 | \$0.00 | \$7.42 | \$0.60 | \$0.00 | \$0.00 | \$46.92 | \$62.38 |
| Equipment Mechanic C | \$27.54 | | \$6.75 | \$0.83 | \$0.28 | \$0.00 | \$6.61 | \$0.60 | \$0.00 | \$0.00 | \$42.61 | \$56.38 |
| Line Truck w/uuger | \$30.44 | | \$6.75 | \$0.91 | \$0.30 | \$0.00 | \$7.31 | \$0.60 | \$0.00 | \$0.00 | \$46.31 | \$61.53 |
| Apprentice | Percent | | | | | | | | | | | |
| 1st 1000 hrs | 60.00 | \$25.93 | \$6.75 | \$0.78 | \$0.26 | \$0.00 | \$6.22 | \$0.60 | \$0.00 | \$0.00 | \$40.54 | \$53.51 |

| | | | | | | | | | | | | |
|--------------|-------|---------|--------|--------|--------|--------|--------|--------|--------|--------|---------|---------|
| 2nd 1000 hrs | 65.00 | \$28.07 | \$6.75 | \$0.84 | \$0.28 | \$0.00 | \$0.74 | \$0.60 | \$0.00 | \$0.00 | \$43.30 | \$57.35 |
| 3rd 1000 hrs | 70.00 | \$30.25 | \$6.75 | \$0.91 | \$0.30 | \$0.00 | \$7.26 | \$0.60 | \$0.00 | \$0.00 | \$46.07 | \$61.20 |
| 4th 1000 hrs | 75.00 | \$32.42 | \$6.75 | \$0.97 | \$0.32 | \$0.00 | \$7.78 | \$0.60 | \$0.00 | \$0.00 | \$48.84 | \$65.04 |
| 5th 1000 hrs | 80.00 | \$34.58 | \$6.75 | \$1.04 | \$0.35 | \$0.00 | \$8.30 | \$0.60 | \$0.00 | \$0.00 | \$51.62 | \$68.90 |
| 6th 1000 hrs | 85.00 | \$36.74 | \$6.75 | \$1.10 | \$0.37 | \$0.00 | \$8.82 | \$0.60 | \$0.00 | \$0.00 | \$54.38 | \$72.75 |
| 7th 1000 hrs | 90.00 | \$38.90 | \$6.75 | \$1.17 | \$0.39 | \$0.00 | \$9.34 | \$0.60 | \$0.00 | \$0.00 | \$57.15 | \$76.60 |

Special Calculation Note : Other is Health Retirement Account

Operator "A"

John Henry Rock Drill, D-6 (or equivalent) and above, Trackhoe Digger, (320 Track excavator), Cranes (greater than 25 tons and less than 45 tons).

Operator "B"

Cranes (greater than 6 tons and up to 25 tons), Backhoes, Road Tractor, Dozer up to D-5, Pressure Digger-wheeled or tracked, all Tension wire Stringing equipment.

Operator "C"

Trench, Backhoe, Riding type vibratory Compactor, Ground Rod Driver, Boom Truck (6 ton & below), Skid Steer Loaders, Material Handler.

Ratio :

(1) Journeyman Lineman to (1) Apprentice

Jurisdiction (* denotes special jurisdictional note) :

ADAMS, ASHLAND, ASHTABULA, ATHENS, AUGLAIZE, BELMONT, BROWN, BUTLER, CARROLL, CHAMPAIGN, CLARK, CLERMONT, CLINTON, COLUMBIANA, COSHOCTON, CRAWFORD, CUYAHOGA, DARKE, DELAWARE, FAIRFIELD, FAYETTE, FRANKLIN, GALLIA, GEAUGA, GREENE, GUERNSEY, HAMILTON, HARRISON, HIGHLAND, HOCKING, HOLMES, JACKSON, JEFFERSON, KNOX, LAKE, LAWRENCE, LICKING, LOGAN, LORAIN, MADISON, MAHONING, MARION, MEDINA, MEIGS, MERCER, MIAMI, MONROE, MONTGOMERY, MORGAN, MORROW, MUSKINGUM, NOBLE, PERRY, PICKAWAY, PIKE, PORTAGE, PREBLE, RICHLAND, ROSS, SCIOTO, SHELBY, STARK, SUMMIT, TRUMBULL, TUSCARAWAS, UNION, VINTON, WARREN, WASHINGTON, WAYNE

Special Jurisdictional Note : 0.30 is for Health Retirement Account.

Details :

Heli - Arc Welding will be paid \$.30 above Journeyman rate. Additional compensation of 10% over the Journeyman Lineman and Journeyman Technician for performing work on structures outside of buildings such as water towers, smoke stacks, radio and television towers, more than 75' above the ground.

Prevailing Wage Rate Skilled Crafts

Name of Union: Electrical Local 71 Voice Data Video Outside

Change # : LCR01-2017fbLoc71VDV

Craft : Voice Data Video Effective Date : 10/18/2017 Last Posted : 10/18/2017

| | BHR | Fringe Benefit Payments | | | | | | Irrevocable Fund | | Total PWR | Overtime Rate |
|-----------------------------------|---------|-------------------------|---------|---------|--------|---------|--------|------------------|----------|-----------|---------------|
| | | H&W | Pension | App Tr. | Vac. | Annuity | Other | LECET (*) | MISC (*) | | |
| Classification | | | | | | | | | | | |
| Electrical Installer Technician I | \$23.46 | \$5.50 | \$0.70 | \$0.00 | \$0.00 | \$0.30 | \$0.00 | \$0.00 | \$0.00 | \$29.96 | \$41.69 |
| Installer Technician II | \$22.37 | \$5.50 | \$0.67 | \$0.00 | \$0.00 | \$0.30 | \$0.00 | \$0.00 | \$0.00 | \$28.84 | \$40.03 |
| Equipment Operator I | \$22.37 | \$5.50 | \$0.67 | \$0.00 | \$0.00 | \$0.30 | \$0.00 | \$0.00 | \$0.00 | \$28.84 | \$40.03 |
| Equipment Operator II | \$18.43 | \$5.50 | \$0.55 | \$0.00 | \$0.00 | \$0.30 | \$0.00 | \$0.00 | \$0.00 | \$24.78 | \$33.99 |
| Installer /Repair Outside | \$22.37 | \$5.50 | \$0.67 | \$0.00 | \$0.00 | \$0.30 | \$0.00 | \$0.00 | \$0.00 | \$28.84 | \$40.03 |
| Ground Driver W/CDL | \$15.83 | \$5.50 | \$0.47 | \$0.00 | \$0.00 | \$0.30 | \$0.00 | \$0.00 | \$0.00 | \$22.10 | \$30.01 |
| Groundman | \$13.24 | \$5.50 | \$0.40 | \$0.00 | \$0.00 | \$0.30 | \$0.00 | \$0.00 | \$0.00 | \$19.44 | \$26.06 |
| Cable Splicer | \$23.46 | \$5.50 | \$0.70 | \$0.00 | \$0.00 | \$0.30 | \$0.00 | \$0.00 | \$0.00 | \$29.96 | \$41.69 |

Special Calculation Note :

Ratio :

Jurisdiction (* denotes special jurisdictional note) :

ADAMS, ASHLAND, ASHTABULA, ATHENS, AUGLAIZE, BELMONT, BROWN, BUTLER, CARROLL, CHAMPAIGN, CLARK, CLERMONT, CLINTON, COLUMBIANA, COSHOCTON, CRAWFORD, CUYAHOGA, DARKE, DELAWARE, FAIRFIELD, FAYETTE, FRANKLIN, GALLIA, GEauga, GREENE, GUERNSEY, HAMILTON, HARRISON, HIGHLAND, HOCKING, HOLMES, JACKSON, JEFFERSON, KNOX, LAKE, LAWRENCE, LICKING, LOGAN, LORAIN, MADISON, MAHONING, MARION, MEDINA, MEIGS, MERCER, MIAMI, MONROE, MONTGOMERY, MORGAN, MORROW, MUSKINGUM, NOBLE, PERRY, PICKAWAY, PIKE, PORTAGE, PREBLE, RICHLAND, ROSS, SCIOTO, SHELBY, STARK, SUMMIT,

Special Jurisdictional Note :

Details :

Cable Splicer: Inspect and test lines or cables, analyze results, and evaluate transmission characteristics. Cover conductors with insulation or seal splices with moisture-proof covering. Install, splice, test, and repair cables using tools or mechanical equipment. This will include the splicing of fiber.

Journeyman Technician I: Must know all aspects of telephone and cable work. This is to include aerial, underground, and manhole work. Must know how to climb and run bucket. Must have all the tools required to perform these tasks. Must be able to be responsible for the safety of the crew at all times. Must also have CDL license and have at least 5 years experience.

Installer/Repairman: Perform tasks of repairing, installing, and testing phone and CATV services.

Technician II: Have at least three years of telephone and CATV experience. Must have the knowledge of underground, aerial, and manhole work. Must be able to climb and operate bucket. Must have CDL. Must have all tools needed to perform these tasks.

Equipment Operator I: Able to operate a digger derrick or bucket truck. Have at least 5 years of experience and must have a valid CDL license.

Equipment Operator II: Able to operate a digger derrick or bucket truck. Have at least 3 years of experience and must have a valid CDL license.

Groundman W/CDL: Must have a valid CDL license and be able to perform tasks such as: climbing poles, pulling downguys, making up material, and getting appropriate tools for the job. Must have at least 5 year's experience.

Groundman: Perform tasks such as: climbing poles, pulling downguys, making up material, and getting appropriate tools for the job. Experience 0-5 years.

Prevailing Wage Rate Skilled Crafts

Name of Union: Electrical Local 82 Inside

Change # : LCN01-2021sksLoc82in

Craft : Electrical Effective Date : 11/29/2021 Last Posted : 11/24/2021

| | BHR | | Fringe Benefit Payments | | | | | Irrevocable Fund | | Total PWR | Overtime Rate | |
|--------------------------|---------|---------|-------------------------|---------|---------|--------|---------|------------------|-----------|-----------|---------------|----------|
| | | | H&W | Pension | App Tr. | Vac. | Annuity | Other | LECET (*) | | | MISC (*) |
| Classification | | | | | | | | | | | | |
| Electrician | \$33.25 | | \$7.45 | \$9.35 | \$0.57 | \$0.00 | \$3.50 | \$0.00 | \$0.00 | \$0.00 | \$54.12 | \$70.74 |
| Apprentice | Percent | | | | | | | | | | | |
| 1st period 0 - 1000 hrs | 42.00 | \$13.97 | \$4.07 | \$0.62 | \$0.24 | \$0.00 | \$0.00 | \$0.00 | \$0.00 | \$0.00 | \$18.89 | \$25.88 |
| 2nd period 1001-2000 hrs | 42.00 | \$13.97 | \$4.07 | \$0.62 | \$0.24 | \$0.00 | \$0.00 | \$0.00 | \$0.00 | \$0.00 | \$18.89 | \$25.88 |
| 3rd period 2001-3500 hrs | 47.00 | \$15.63 | \$6.92 | \$4.39 | \$0.27 | \$0.00 | \$1.65 | \$0.00 | \$0.00 | \$0.00 | \$28.86 | \$36.67 |
| 4th period 3501-5000 hrs | 52.00 | \$17.29 | \$6.97 | \$4.86 | \$0.29 | \$0.00 | \$1.82 | \$0.00 | \$0.00 | \$0.00 | \$31.23 | \$39.88 |
| 5th period 5001-6500 hrs | 62.03 | \$20.62 | \$7.07 | \$5.80 | \$0.35 | \$0.00 | \$2.17 | \$0.00 | \$0.00 | \$0.00 | \$36.01 | \$46.33 |
| 6th period 6501-8000 hrs | 77.00 | \$25.60 | \$7.22 | \$7.20 | \$0.44 | \$0.00 | \$2.70 | \$0.00 | \$0.00 | \$0.00 | \$43.16 | \$55.96 |

Special Calculation Note : No special calculations for this skilled craft wage rate are required at this time.

Ratio :

1 to 3 Journeymen to 3 Apprentices
4 to 6 Journeymen to 6 Apprentices
per job site

Jurisdiction (* denotes special jurisdictional note) :

CLINTON, DARKE, GREENE, MIAMI,
MONTGOMERY, PREBLE, WARREN*

Special Jurisdictional Note : The following townships in Warren County are included: Clearcreek, Franklin and Wayne.

Details :

Only correction made on 6-19-19 was the 5th year Apprentice fb.

Prevailing Wage Rate Skilled Crafts

Name of Union: Electrical Local 82 Lightning Rod

Change # : LCR01-2022sksLoc82

Craft : Electrical Effective Date : 01/05/2022 Last Posted : 01/05/2022

| | BHR | Fringe Benefit Payments | | | | | | Irrevocable Fund | | Total PWR | Overtime Rate |
|------------------------------------|---------|-------------------------|---------|---------|--------|---------|--------|------------------|----------|-----------|---------------|
| | | H&W | Pension | App Tr. | Vac. | Annuity | Other | LECET (*) | MISC (*) | | |
| Classification | | | | | | | | | | | |
| Electrical Lightning Rod Technican | \$31.79 | \$7.45 | \$9.30 | \$0.00 | \$0.00 | \$3.50 | \$0.00 | \$0.00 | \$0.00 | \$52.04 | \$67.93 |
| | | | | | | | | | | | |

Special Calculation Note : No Apprentice approved by OSAC.

Ratio :

Jurisdiction (* denotes special jurisdictional note) :

CLINTON, DARKE, GREENE, MIAMI,
MONTGOMERY, PREBLE, WARREN*

Special Jurisdictional Note : The following townships in Warren County are included: (Clearcreek, Franklin and Wayne)

Details :

Prevailing Wage Rate Skilled Crafts

Name of Union: Electrical Local 82 Voice Data Video

Change # : LCN01-2021sksLoc82VDV

Craft : Voice Data Video Effective Date : 11/29/2021 Last Posted : 11/24/2021

| | BHR | Fringe Benefit Payments | | | | | | Irrevocable Fund | | Total PWR | Overtime Rate |
|---|---------|-------------------------|---------|---------|--------|---------|--------|------------------|----------|-----------|---------------|
| | | H&W | Pension | App Tr. | Vac. | Annuity | Other | LECET (*) | MISC (*) | | |
| Classification | | | | | | | | | | | |
| Electrical Installer Technician A | \$25.95 | \$6.60 | \$0.78 | \$0.49 | \$0.00 | \$4.40 | \$0.00 | \$0.00 | \$0.00 | \$38.22 | \$51.20 |
| Electrical Installer Technician B | \$24.65 | \$6.60 | \$0.74 | \$0.47 | \$0.00 | \$4.40 | \$0.00 | \$0.00 | \$0.00 | \$36.86 | \$49.18 |
| JW Installer Technician | \$23.36 | \$6.60 | \$0.70 | \$0.44 | \$0.00 | \$4.40 | \$0.00 | \$0.00 | \$0.00 | \$35.50 | \$47.18 |
| NON BICSI Installer | \$16.87 | \$3.00 | \$0.51 | \$0.32 | \$0.00 | \$2.00 | \$0.00 | \$0.00 | \$0.00 | \$22.70 | \$31.14 |
| Apprentice Indentured Before 09-03-2018 | | | | | | | | | | | |
| 1st Period 0-1000 Hrs | \$12.98 | \$6.60 | \$0.39 | \$0.25 | \$0.00 | \$0.25 | \$0.00 | \$0.00 | \$0.00 | \$20.47 | \$26.96 |
| 2nd Period 1001-2000 Hrs | \$12.98 | \$6.60 | \$0.39 | \$0.25 | \$0.00 | \$0.25 | \$0.00 | \$0.00 | \$0.00 | \$20.47 | \$26.96 |
| 3rd Period 2001-3000 Hrs | \$15.57 | \$6.60 | \$0.47 | \$0.30 | \$0.00 | \$4.40 | \$0.00 | \$0.00 | \$0.00 | \$27.34 | \$35.13 |
| 4th Period 3001-4000Hrs | \$16.87 | \$6.60 | \$0.51 | \$0.32 | \$0.00 | \$4.40 | \$0.00 | \$0.00 | \$0.00 | \$28.70 | \$37.14 |
| 5th Period 4001-5000 Hrs | \$18.17 | \$6.60 | \$0.55 | \$0.35 | \$0.00 | \$4.40 | \$0.00 | \$0.00 | \$0.00 | \$30.07 | \$39.16 |
| 6th Period 5001-6000 Hrs | \$19.46 | \$6.60 | \$0.58 | \$0.37 | \$0.00 | \$4.40 | \$0.00 | \$0.00 | \$0.00 | \$31.41 | \$41.14 |
| Cable | \$12.98 | \$3.00 | \$0.39 | \$0.25 | \$0.00 | \$0.25 | \$0.00 | \$0.00 | \$0.00 | \$16.87 | \$23.36 |

| Puller | | | | | | | | | | | | | |
|--|---------|---------|--------|--------|--------|--------|--------|--------|--------|--------|--------|---------|---------|
| Apprentice Indentured After 09-04-2018 | Percent | | | | | | | | | | | | |
| 1st 0-1000 hours | 55.00 | \$14.27 | \$3.00 | \$0.43 | \$0.27 | \$0.00 | \$0.25 | \$0.00 | \$0.00 | \$0.00 | \$0.00 | \$18.22 | \$25.36 |
| 2nd 1001-2000 hours | 55.00 | \$14.27 | \$3.00 | \$0.43 | \$0.27 | \$0.00 | \$0.25 | \$0.00 | \$0.00 | \$0.00 | \$0.00 | \$18.22 | \$25.36 |
| 3rd 2001-3000 hours | 65.00 | \$16.87 | \$6.50 | \$0.51 | \$0.32 | \$0.00 | \$4.40 | \$0.00 | \$0.00 | \$0.00 | \$0.00 | \$28.60 | \$37.03 |
| 4th 3001-4000 hours | 65.00 | \$16.87 | \$6.50 | \$0.51 | \$0.32 | \$0.00 | \$4.40 | \$0.00 | \$0.00 | \$0.00 | \$0.00 | \$28.60 | \$37.03 |
| 5th 4001-5000 hours | 75.00 | \$19.46 | \$6.53 | \$0.58 | \$0.37 | \$0.00 | \$4.40 | \$0.00 | \$0.00 | \$0.00 | \$0.00 | \$31.34 | \$41.07 |
| 6th 5001-6000 hours | 75.00 | \$19.46 | \$6.53 | \$0.58 | \$0.37 | \$0.00 | \$4.40 | \$0.00 | \$0.00 | \$0.00 | \$0.00 | \$31.34 | \$41.07 |
| 7th 6001-7000 hours | 80.00 | \$20.76 | \$6.54 | \$0.62 | \$0.39 | \$0.00 | \$4.40 | \$0.00 | \$0.00 | \$0.00 | \$0.00 | \$32.71 | \$43.09 |
| 8th 7001 hours | 80.00 | \$20.76 | \$6.54 | \$0.62 | \$0.39 | \$0.00 | \$4.40 | \$0.00 | \$0.00 | \$0.00 | \$0.00 | \$32.71 | \$43.09 |
| Cable Puller | 50.00 | \$12.98 | \$3.00 | \$0.39 | \$0.25 | \$0.00 | \$0.25 | \$0.00 | \$0.00 | \$0.00 | \$0.00 | \$16.86 | \$23.35 |

Special Calculation Note : No special calculations for this skilled craft wage rate are required at this time.

Ratio :

1 Journeymen to 2 Apprentice
(Indentured After 9-4-2018)

1 Journeymen to 2 Apprentice
(Indentured Before 9--03-2018)

Jurisdiction (* denotes special jurisdictional note) :

CLINTON, DARKE, GREENE, MIAMI,
MONTGOMERY, PREBLE, WARREN*

Special Jurisdictional Note : The following townships in Warren County are included: (Clearcreek, Franklin and Wayne)

Details :

Work covered but not limited to: installation which utilize transmission and/or transference of voice, sound, vision or digital for commercial, education, security and entertainment purposes for the following:

TV monitoring and surveillance, background-foreground music, intercom and telephone interconnect, inventory control systems, microwave transmission, multimedia, multiplex, nurse call system, radio page, school intercom, sound and low voltage master clock systems.

Fire Alarm work is excluded on all new construction sites or wherever the fire alarm system is installed in conduit.

All HVAC control work is not covered by this wage rate but by the Inside Electrical wage rate.

Prevailing Wage Rate

Skilled Crafts

Name of Union: Electrical Local 648 Voice Data Video

Change # : LCR01-2020fbLoc648VDV

Craft : Voice Data Video Effective Date : 12/03/2020 Last Posted : 12/03/2020

| | BHR | Fringe Benefit Payments | | | | | | Irrevocable Fund | | Total PWR | Overtime Rate |
|--|---------|-------------------------|---------|---------|--------|---------|--------|------------------|----------|-----------|---------------|
| | | H&W | Pension | App Tr. | Vac. | Annuity | Other | LECET (*) | MISC (*) | | |
| Classification | | | | | | | | | | | |
| Electrical Installer Technician A | \$25.10 | \$6.60 | \$0.75 | \$0.48 | \$0.00 | \$4.40 | \$0.00 | \$0.00 | \$0.00 | \$37.33 | \$49.88 |
| Electrical Installer Technician B | \$23.85 | \$6.60 | \$0.72 | \$0.45 | \$0.00 | \$4.40 | \$0.00 | \$0.00 | \$0.00 | \$36.02 | \$47.95 |
| JW Installer Technician B | \$22.59 | \$6.60 | \$0.68 | \$0.43 | \$0.00 | \$4.40 | \$0.00 | \$0.00 | \$0.00 | \$34.70 | \$46.00 |
| Non BICSI Installer | \$16.32 | \$3.00 | \$0.49 | \$0.31 | \$0.00 | \$2.00 | \$0.00 | \$0.00 | \$0.00 | \$22.12 | \$30.28 |
| Apprentice Indentured AFTER 09-03-2018 | | | | | | | | | | | |
| 1 st Period 0-800 Hrs | \$13.81 | \$3.00 | \$0.41 | \$0.26 | \$0.00 | \$0.25 | \$0.00 | \$0.00 | \$0.00 | \$17.73 | \$24.64 |
| 2nd Period 801-1600 Hrs | \$13.81 | \$3.00 | \$0.41 | \$0.26 | \$0.00 | \$0.25 | \$0.00 | \$0.00 | \$0.00 | \$17.73 | \$24.64 |
| 3rd Period 1601-2400 Hrs | \$16.32 | \$6.50 | \$0.49 | \$0.31 | \$0.00 | \$4.40 | \$0.00 | \$0.00 | \$0.00 | \$28.02 | \$36.18 |
| 4th Period 2401-3200 Hrs | \$16.32 | \$6.50 | \$0.49 | \$0.31 | \$0.00 | \$4.40 | \$0.00 | \$0.00 | \$0.00 | \$28.02 | \$36.18 |
| 5th Period 3201-4000 Hrs | \$18.83 | \$6.53 | \$0.56 | \$0.36 | \$0.00 | \$4.40 | \$0.00 | \$0.00 | \$0.00 | \$30.68 | \$40.10 |
| 6th Period 4001-4800 Hrs | \$18.83 | \$6.53 | \$0.56 | \$0.36 | \$0.00 | \$4.40 | \$0.00 | \$0.00 | \$0.00 | \$30.68 | \$40.10 |
| 7th Period | \$20.08 | \$6.54 | \$0.60 | \$0.38 | \$0.00 | \$4.40 | \$0.00 | \$0.00 | \$0.00 | \$32.00 | \$42.04 |

| | | | | | | | | | | | | |
|--|----------------|---------|--------|--------|--------|--------|--------|--------|--------|--------|---------|---------|
| 4801-5600 Hrs | | | | | | | | | | | | |
| 8th Period 5601-6400 | \$20.08 | \$6.54 | \$0.60 | \$0.38 | \$0.00 | \$4.40 | \$0.00 | \$0.00 | \$0.00 | \$0.00 | \$32.00 | \$42.04 |
| Cable Puller | \$12.55 | \$3.00 | \$0.38 | \$0.25 | \$0.00 | \$0.25 | \$0.00 | \$0.00 | \$0.00 | \$0.00 | \$16.43 | \$22.71 |
| Apprentice Indentured PRIOR to 09-03-2018 | Percent | | | | | | | | | | | |
| 1st period 0-800 hrs | 50.00 | \$12.55 | \$6.50 | \$0.37 | \$0.23 | \$0.00 | \$0.25 | \$0.00 | \$0.00 | \$0.00 | \$19.90 | \$26.18 |
| 2nd period 801-1600 hrs | 50.00 | \$12.55 | \$6.50 | \$0.37 | \$0.23 | \$0.00 | \$0.25 | \$0.00 | \$0.00 | \$0.00 | \$19.90 | \$26.18 |
| 3rd period 1601-2400 hrs | 60.00 | \$15.06 | \$6.50 | \$0.44 | \$0.28 | \$0.00 | \$4.40 | \$0.00 | \$0.00 | \$0.00 | \$26.68 | \$34.21 |
| 4th period 2401-3200 hrs | 65.00 | \$16.32 | \$6.50 | \$0.47 | \$0.30 | \$0.00 | \$4.40 | \$0.00 | \$0.00 | \$0.00 | \$27.98 | \$36.14 |
| 5th period 3201-4000 hrs | 70.00 | \$17.57 | \$6.50 | \$0.51 | \$0.32 | \$0.00 | \$4.40 | \$0.00 | \$0.00 | \$0.00 | \$29.30 | \$38.09 |
| 6th period 4001-4800 hrs | 75.00 | \$18.83 | \$6.50 | \$0.55 | \$0.35 | \$0.00 | \$4.40 | \$0.00 | \$0.00 | \$0.00 | \$30.63 | \$40.04 |
| Cable Puller | 50.00 | \$12.55 | \$3.00 | \$0.37 | \$0.23 | \$0.00 | \$0.25 | \$0.00 | \$0.00 | \$0.00 | \$16.40 | \$22.68 |

Special Calculation Note :**Ratio :**

1 Technician to 2 Apprentice

Jurisdiction (* denotes special jurisdictional note) :

BUTLER, WARREN*

Special Jurisdictional Note : The following townships In Warren County are included: (Deerfield, Hamilton, Harlan, Massie, Salem, Turtle Creek, Union, and Washington)

Details :

The following work is excluded from the Teledata Technician work scope:

*The installation of computer systems in industrial applications such as assembly lines, robotics, computer controller manufacturing systems.

*The installation of conduit and/or raceways shall be installed by Inside Wireman. On sites where there is no Inside Wireman employed, the Teledata Technician may install raceway or conduit not greater than 10 ft.

*Fire Alarm work is excluded on all new construction sites or wherever the fire alarm system is installed in conduit

*All HVAC control work.

Prevailing Wage Rate Skilled Crafts

Name of Union: Electrical Local 648 Inside

Change # : LCN01-2021sksLoc648in

Craft : Electrical Effective Date : 09/15/2021 Last Posted : 09/15/2021

| | BHR | | Fringe Benefit Payments | | | | | Irrevocable Fund | | Total PWR | Overtime Rate | |
|---------------------------------|---------|---------|-------------------------|---------|---------|--------|---------|------------------|-----------|-----------|---------------|----------|
| | | | H&W | Pension | App Tr. | Vac. | Annuity | Other | LECET (*) | | | MISC (*) |
| Classification | | | | | | | | | | | | |
| Electrician | \$32.00 | | \$7.25 | \$8.05 | \$0.48 | \$0.00 | \$4.05 | \$0.96 | \$0.00 | \$0.00 | \$52.79 | \$68.79 |
| | | | | | | | | | | | | |
| | | | | | | | | | | | | |
| | | | | | | | | | | | | |
| | | | | | | | | | | | | |
| | | | | | | | | | | | | |
| | | | | | | | | | | | | |
| Apprentice | Percent | | | | | | | | | | | |
| 1st period 0-1000 hrs | 45.00 | \$14.40 | \$4.22 | \$0.00 | \$0.22 | \$0.00 | \$2.82 | \$0.43 | \$0.00 | \$0.00 | \$22.09 | \$29.29 |
| 2nd period 1001- 2000 hrs | 47.00 | \$15.04 | \$4.22 | \$0.00 | \$0.23 | \$0.00 | \$2.83 | \$0.45 | \$0.00 | \$0.00 | \$22.77 | \$30.29 |
| 3rd period 2001- 3500 hrs | 51.00 | \$16.32 | \$7.25 | \$4.11 | \$0.24 | \$0.00 | \$3.29 | \$0.49 | \$0.00 | \$0.00 | \$31.70 | \$39.86 |
| 4th period 3501- 5000 hrs | 55.00 | \$17.60 | \$7.25 | \$4.43 | \$0.26 | \$0.00 | \$3.36 | \$0.53 | \$0.00 | \$0.00 | \$33.43 | \$42.23 |
| 5th period 5001- 6500 hrs | 62.00 | \$19.84 | \$7.25 | \$4.99 | \$0.30 | \$0.00 | \$3.46 | \$0.60 | \$0.00 | \$0.00 | \$36.44 | \$46.36 |
| 6th period 6501- 8000 hrs | 71.00 | \$22.72 | \$7.25 | \$5.72 | \$0.34 | \$0.00 | \$3.61 | \$0.68 | \$0.00 | \$0.00 | \$40.32 | \$51.68 |

Special Calculation Note : Other is NEBF (National Electrical Benefit Fund.)

Ratio :

3 Journeyman to 2 Apprentices or fraction thereof:
 1-3 Journeymen to 2 Apprentice
 4-6 Journeymen to 4 Apprentice
 7-9 Journeymen to 6 Apprentice
 first person assigned to any job site shall be a journeyman

Jurisdiction (* denotes special jurisdictional note) :

BUTLER, WARREN*

Special Jurisdictional Note : In Warren County the following townships are included: (Deerfield, Hamilton, Harlan, Massie, Salem, Turtle Creek, Union, and Washington)

Details :

Electricians while splicing cable shall receive \$.50 an hour above the regular electrical rate.

All work that requires the use of gas masks or respirators, shall be paid 50% above the appropriate rate of pay. Work up to & including 40 feet shall be paid \$.50 over the journeyman rate. All work from a Boatswain Chair, Swinging Scaffold, or Barrel shall be at double the Journeyman rate. Workmen required to work 50 feet or more below the surface of the earth will be paid 50% above the Journeyman rate.

| | | | | | | | | | | | | |
|---------------------------------|-------|---------|--------|--------|--------|--------|--------|--------|--------|--------|---------|---------|
| 5th period 5001- 6500 hrs | 62.00 | \$19.22 | \$7.25 | \$5.21 | \$0.29 | \$0.00 | \$2.81 | \$0.58 | \$0.00 | \$0.00 | \$35.36 | \$44.97 |
| 6th period 6501- 8000 hrs | 71.00 | \$22.01 | \$7.25 | \$5.96 | \$0.33 | \$0.00 | \$2.86 | \$0.66 | \$0.00 | \$0.00 | \$39.07 | \$50.07 |

Special Calculation Note : Other is for NEBF (National Electrical Benefit Fund)

Ratio :

1 Journeymen to 3 Apprentice
 4 Journeymen to 6 Apprentice
 first person assigned to any job site shall be a journeyman

Jurisdiction (* denotes special jurisdictional note) :

BUTLER, WARREN*

Construction Electrician and Construction Wireman Ratio

There shall be a minimum ratio of one inside Journeyman to every (4) employees of different classification per jobsite. An inside Journeyman Wireman is required on the project as the fifth (5th) worker or when apprentices are used

Special Jurisdictional Note : In Warren County the following townships are included: (Deerfield, Hamilton, Harlan, Massie, Salem, Turtle Creek, Union, and Washington)

The scope of work for the light commercial agreement shall apply to the following facilities not to exceed 200,000 square feet; office buildings, shopping centers, auto sales agencies and garages, churches, funeral homes, nursing homes, hotels, retail and wholesale facilities, small stand-alone manufacturing facilities when free standing and not part of a larger facility (not to exceed 50,000 square fee), solar projects (500 panels or less) unless otherwise covered under the agreement, lighting retrofits (when not associated with remodels involving branch re-circuiting) lighting retrofits shall be defined as the changing of lamps and ballasts in existing light fixtures and shall also include the one for one replacement of existing fixtures, warehouses, gas stations, food service centers, restaurants, entertainment facilities, hospitals, clinics, motels, residential buildings.

Details :

Electricians while splicing cable shall receive \$.50 an hour above the regular electrical rate.

All work that requires the use of gas masks or respirators, shall be paid 50% above the appropriate rate of pay. Work up to & including 40 feet shall be paid \$.50 over the journeyman rate. All work from a Boatswain Chair, Swinging Scaffold, or Barrel shall be at double the Journeyman rate. Workmen required to work 50 feet or more below the surface of the earth will be paid 50% above the Journeyman rate.

Prevailing Wage Rate Skilled Crafts

Name of Union: Electrical Local 648 Lt Commercial South West

Change # : LCN01-2021sksLoc648in

Craft : Electrical Effective Date : 01/01/2022 Last Posted : 12/22/2021

| | BHR | Fringe Benefit Payments | | | | | | Irrevocable Fund | | Total PWR | Overtime Rate |
|----------------------------------|---------|-------------------------|---------|---------|--------|---------|--------|------------------|----------|-----------|---------------|
| | | H&W | Pension | App Tr. | Vac. | Annuity | Other | LECET (*) | MISC (*) | | |
| Classification | | | | | | | | | | | |
| Electrician | \$32.00 | \$7.25 | \$8.05 | \$0.48 | \$0.00 | \$4.05 | \$0.12 | \$0.00 | \$0.00 | \$51.95 | \$67.95 |
| CE-3 12,001- 14,000 Hrs | \$24.66 | \$6.47 | \$0.74 | \$0.72 | \$0.00 | \$0.74 | \$0.12 | \$0.00 | \$0.00 | \$33.45 | \$45.78 |
| CE-2 10,001- 12,000 Hrs | \$19.56 | \$6.47 | \$0.59 | \$0.72 | \$0.00 | \$0.59 | \$0.12 | \$0.00 | \$0.00 | \$28.05 | \$37.83 |
| CE-1 8,001- 10,000 Hrs | \$17.86 | \$6.47 | \$0.54 | \$0.72 | \$0.00 | \$0.54 | \$0.12 | \$0.00 | \$0.00 | \$26.25 | \$35.18 |
| CW-4 6,001- 8,000 Hrs | \$16.16 | \$6.47 | \$0.48 | \$0.72 | \$0.00 | \$0.48 | \$0.12 | \$0.00 | \$0.00 | \$24.43 | \$32.51 |
| CW-3 4,001- 6,000 Hrs | \$14.46 | \$6.47 | \$0.43 | \$0.72 | \$0.00 | \$0.43 | \$0.12 | \$0.00 | \$0.00 | \$22.63 | \$29.86 |
| CW-2 2,001- 4,000 Hrs | \$13.61 | \$6.47 | \$0.41 | \$0.72 | \$0.00 | \$0.41 | \$0.12 | \$0.00 | \$0.00 | \$21.74 | \$28.54 |
| CW-1 0- 2,000 Hrs | \$12.76 | \$6.47 | \$0.38 | \$0.72 | \$0.00 | \$0.38 | \$0.12 | \$0.00 | \$0.00 | \$20.83 | \$27.21 |

Special Calculation Note : Other is for NEBF (National Electrical Benefit Fund)

Ratio :

Construction Electrician and Construction Wireman Ratio

There shall be a minimum ratio of one inside Journeyman to every (4) employees of different classification per jobsite. An inside Journeyman Wireman is required on the project as the fifth (5th) worker or when apprentices are used

Jurisdiction (* denotes special jurisdictional note) :

BUTLER, WARREN*

Special Jurisdictional Note : In Warren County the following townships are included: (Deerfield, Hamilton, Harlan, Massie, Salem, Turtle Creek, Union, and Washington)

The scope of work for the light commercial agreement shall apply to the following facilities not to exceed 200,000 square feet; office buildings, shopping centers, auto sales agencies and garages, churches, funeral homes, nursing homes, hotels, retail and wholesale facilities, small stand-alone manufacturing facilities when free standing and not part of a larger facility (not to exceed 50,000 square feet), solar projects (500 panels or less) unless otherwise covered under the agreement, lighting retrofits (when not associated with remodels involving branch re-circuiting) lighting retrofits shall be defined as the changing of lamps and ballasts in existing light fixtures and shall also include the one for one replacement of existing fixtures, warehouses, gas stations, food service centers, restaurants, entertainment facilities, hospitals, clinics, motels, residential buildings.

Details :

Electricians while splicing cable shall receive \$.50 an hour above the regular electrical rate.

All work that requires the use of gas masks or respirators, shall be paid 50% above the appropriate rate of pay. Work up to & including 40 feet shall be paid \$.50 over the journeyman rate. All work from a Boatswain Chair, Swinging Scaffold, or Barrel shall be at double the Journeyman rate. Workmen required to work 50 feet or more below the surface of the earth will be paid 50% above the Journeyman rate.

Prevailing Wage Rate Skilled Crafts

Name of Union: Electrical Local 648 Voice Data Video

Change # : LCR01-2021sksLoc648VDV

Craft : Voice Data Video Effective Date : 12/22/2021 Last Posted : 12/22/2021

| | BHR | | Fringe Benefit Payments | | | | | Irrevocable Fund | | Total PWR | Overtime Rate | |
|-----------------------------------|---------|---------|-------------------------|---------|---------|--------|---------|------------------|-----------|-----------|---------------|----------|
| | | | H&W | Pension | App Tr. | Vac. | Annuity | Other | LECET (*) | | | MISC (*) |
| Classification | | | | | | | | | | | | |
| Electrical Installer Technician A | \$25.95 | | \$6.60 | \$0.78 | \$0.49 | \$0.00 | \$4.40 | \$0.00 | \$0.00 | \$0.00 | \$38.22 | \$51.20 |
| Electrical Installer Technician B | \$24.65 | | \$6.60 | \$0.74 | \$0.47 | \$0.00 | \$4.40 | \$0.00 | \$0.00 | \$0.00 | \$36.86 | \$49.18 |
| JW Installer Technician B | \$23.36 | | \$6.60 | \$0.70 | \$0.44 | \$0.00 | \$4.40 | \$0.00 | \$0.00 | \$0.00 | \$35.50 | \$47.18 |
| Non BICSI Installer | \$16.87 | | \$3.00 | \$0.51 | \$0.32 | \$0.00 | \$2.40 | \$0.00 | \$0.00 | \$0.00 | \$23.10 | \$31.53 |
| Apprentice | | | | | | | | | | | | |
| | Percent | | | | | | | | | | | |
| 1st period 0-800 hrs | 55.00 | \$14.27 | \$3.00 | \$0.43 | \$0.27 | \$0.00 | \$0.25 | \$0.00 | \$0.00 | \$0.00 | \$18.22 | \$25.36 |
| 2nd period 801-1600 hrs | 55.00 | \$14.27 | \$3.00 | \$0.43 | \$0.27 | \$0.00 | \$0.25 | \$0.00 | \$0.00 | \$0.00 | \$18.22 | \$25.36 |
| 3rd period 1601-2400 hrs | 65.00 | \$16.87 | \$6.50 | \$0.51 | \$0.32 | \$0.00 | \$4.40 | \$0.00 | \$0.00 | \$0.00 | \$28.60 | \$37.03 |
| 4th period 2401-3200 hrs | 65.00 | \$16.87 | \$6.50 | \$0.51 | \$0.32 | \$0.00 | \$4.40 | \$0.00 | \$0.00 | \$0.00 | \$28.60 | \$37.03 |
| 5th period 3201-4000 hrs | 75.00 | \$19.46 | \$6.53 | \$0.58 | \$0.37 | \$0.00 | \$4.40 | \$0.00 | \$0.00 | \$0.00 | \$31.34 | \$41.07 |
| 6th period 4001-4800 hrs | 75.00 | \$19.46 | \$6.53 | \$0.58 | \$0.37 | \$0.00 | \$4.40 | \$0.00 | \$0.00 | \$0.00 | \$31.34 | \$41.07 |
| 7th period 4801-4900hr | 80.00 | \$20.76 | \$6.54 | \$0.62 | \$0.39 | \$0.00 | \$4.40 | \$0.00 | \$0.00 | \$0.00 | \$32.71 | \$43.09 |

| | | | | | | | | | | | | |
|--------------------------------|-------|---------|--------|--------|--------|--------|--------|--------|--------|--------|---------|---------|
| 8th period 4901- 5000hrs | 80.00 | \$20.76 | \$6.54 | \$0.62 | \$0.39 | \$0.00 | \$4.40 | \$0.00 | \$0.00 | \$0.00 | \$32.71 | \$43.09 |
| Cable Puller | 50.00 | \$12.98 | \$3.00 | \$0.39 | \$0.25 | \$0.00 | \$0.25 | \$0.00 | \$0.00 | \$0.00 | \$16.86 | \$23.35 |

Special Calculation Note :

Ratio :

1 Technician to 2 Apprentice

Jurisdiction (* denotes special jurisdictional note) :

BUTLER, WARREN*

Special Jurisdictional Note : The following townships In Warren County are included: (Deerfield, Hamilton, Harlan, Massie, Salem, Turtle Creek, Union, and Washington)

Details :

The following work is excluded from the Teledata Technician work scope:

- *The installation of computer systems in industrial applications such as assembly lines, robotics, computer controller manufacturing systems.
- *The installation of conduit and/or raceways shall be installed by Inside Wireman. On sites where there is no Inside Wireman employed, the Teledata Technician may install raceway or conduit not greater than 10 ft.
- *Fire Alarm work is excluded on all new construction sites or wherever the fire alarm system is installed in conduit
- *All HVAC control work.

Prevailing Wage Rate Skilled Crafts

Name of Union: Elevator Local 11

Change # : LCN01-2020fbLoc11

Craft : Elevator Effective Date : 01/05/2021 Last Posted : 01/05/2021

| | BHR | | Fringe Benefit Payments | | | | | | Irrevocable Fund | | Total PWR | Overtime Rate |
|-------------------------|---------|---------|-------------------------|---------|---------|--------|---------|--------|------------------|----------|-----------|---------------|
| | | | H&W | Pension | App Tr. | Vac. | Annuity | Other | LECET (*) | MISC (*) | | |
| Classification | | | | | | | | | | | | |
| Elevator Mechanic | \$48.82 | | \$15.88 | \$10.46 | \$0.64 | \$3.91 | \$8.85 | \$1.56 | \$0.00 | \$0.00 | \$90.12 | \$114.53 |
| Probationary Apprentice | 50.00 | \$24.41 | \$0.00 | \$0.00 | \$0.00 | \$1.46 | \$0.00 | \$0.78 | \$0.00 | \$0.00 | \$26.65 | \$38.86 |
| 1st year | 55.00 | \$26.85 | \$15.88 | \$10.46 | \$0.64 | \$1.61 | \$8.85 | \$0.86 | \$0.00 | \$0.00 | \$65.15 | \$78.58 |
| 2nd year | 65.00 | \$31.73 | \$15.88 | \$10.46 | \$0.64 | \$1.90 | \$8.85 | \$1.02 | \$0.00 | \$0.00 | \$70.48 | \$86.35 |
| 3rd year | 70.00 | \$34.17 | \$15.88 | \$10.46 | \$0.64 | \$2.05 | \$8.85 | \$1.09 | \$0.00 | \$0.00 | \$73.14 | \$90.23 |
| 4th year | 80.00 | \$39.06 | \$15.88 | \$10.46 | \$0.64 | \$2.34 | \$8.85 | \$1.25 | \$0.00 | \$0.00 | \$78.48 | \$98.00 |
| Helper | 70.00 | \$34.17 | \$15.88 | \$10.46 | \$0.64 | \$2.05 | \$8.85 | \$1.09 | \$0.00 | \$0.00 | \$73.14 | \$90.23 |
| Assistant Mechanic | 80.00 | \$39.06 | \$15.88 | \$10.46 | \$0.64 | \$2.34 | \$8.85 | \$1.25 | \$0.00 | \$0.00 | \$78.48 | \$98.00 |

Special Calculation Note : Other is Holiday Pay. Vacation calculated at 6%.

Ratio :

The total number of Helpers & Apprentices employed shall not exceed the number of Mechanics on any one job, except on jobs where (2) teams or more are working, (1) extra Helper or Apprentice may be employed for the first (2) teams and an extra Helper or Apprentice for each additional (3) teams.

- 1 Journeymen to 1 Apprentice
- 2 Journeymen to 5 Apprentice
- 3 Journeymen to 6 Apprentice

Special Jurisdictional Note :

Details :

Jurisdiction (* denotes special jurisdictional note) :

ADAMS, BROWN, BUTLER, CLERMONT, CLINTON, DARKE, GREENE, HAMILTON, HIGHLAND, MIAMI, MONTGOMERY, PREBLE, SCIOTO, SHELBY, WARREN

Prevailing Wage Rate

Skilled Crafts

Name of Union: Glazier Local 387

Change # : LCN01-2020fbLoc387

Craft : Glazier Effective Date : 11/01/2020 Last Posted : 10/28/2020

| | BHR | | Fringe Benefit Payments | | | | | | Irrevocable Fund | | Total PWR | Overtime Rate |
|----------------|---------|---------|-------------------------|---------|---------|--------|---------|--------|------------------|----------|-----------|---------------|
| | | | H&W | Pension | App Tr. | Vac. | Annuity | Other | LECET (*) | MISC (*) | | |
| Classification | | | | | | | | | | | | |
| Glazier | \$27.93 | | \$5.67 | \$10.10 | \$0.25 | \$0.00 | \$0.00 | \$0.00 | \$0.00 | \$0.00 | \$43.95 | \$57.92 |
| Apprentice | Percent | | | | | | | | | | | |
| 1st 6 months | 53.70 | \$15.00 | \$5.67 | \$0.00 | \$0.25 | \$0.00 | \$0.00 | \$0.00 | \$0.00 | \$0.00 | \$20.92 | \$28.42 |
| 2nd 6 months | 65.00 | \$18.15 | \$5.67 | \$6.19 | \$0.25 | \$0.00 | \$0.00 | \$0.00 | \$0.00 | \$0.00 | \$30.26 | \$39.34 |
| 3rd 6 months | 70.00 | \$19.55 | \$5.67 | \$6.71 | \$0.25 | \$0.00 | \$0.00 | \$0.00 | \$0.00 | \$0.00 | \$32.18 | \$41.96 |
| 4th 6 months | 75.00 | \$20.95 | \$5.67 | \$6.85 | \$0.25 | \$0.00 | \$0.00 | \$0.00 | \$0.00 | \$0.00 | \$33.72 | \$44.19 |
| 5th 6 months | 80.00 | \$22.34 | \$5.67 | \$7.43 | \$0.25 | \$0.00 | \$0.00 | \$0.00 | \$0.00 | \$0.00 | \$35.69 | \$46.87 |
| 6th 6 months | 85.00 | \$23.74 | \$5.67 | \$7.57 | \$0.25 | \$0.00 | \$0.00 | \$0.00 | \$0.00 | \$0.00 | \$37.23 | \$49.10 |
| 7th 6 months | 90.00 | \$25.14 | \$5.67 | \$8.09 | \$0.25 | \$0.00 | \$0.00 | \$0.00 | \$0.00 | \$0.00 | \$39.15 | \$51.72 |
| 8th 6 months | 95.00 | \$26.53 | \$5.67 | \$8.68 | \$0.25 | \$0.00 | \$0.00 | \$0.00 | \$0.00 | \$0.00 | \$41.13 | \$54.40 |

Special Calculation Note : No special calculations for this skilled craft wage rate are required at this time.

Ratio :

Each employer may employ and train Apprentices in the following ratio to journeymen workers employed.
1 Journeymen to 1 Apprentice

Jurisdiction (* denotes special jurisdictional note) :

ADAMS, BROWN, BUTLER, CHAMPAIGN, CLARK, CLERMONT, CLINTON, DARKE, FAYETTE*, GREENE, HAMILTON, HIGHLAND, MIAMI, MONTGOMERY, PREBLE, SHELBY*, WARREN

Special Jurisdictional Note : Fayette County: Eastern portion of route #41 being the dividing line between locals 372 and 387. Local 387 has jurisdiction of projects built on property which borders route #41 East. Shelby County: Southern portion of routes #47 & 29.

Details :

Prevailing Wage Rate Skilled Crafts

Name of Union: Ironworker Local 44

Change # : LCNO1-2021fbLoc44

Craft : Ironworker Effective Date : 06/24/2021 Last Posted : 06/24/2021

| | BHR | | Fringe Benefit Payments | | | | | Irrevocable Fund | | Total PWR | Overtime Rate | |
|------------------------|----------------|---------|-------------------------|---------|---------|--------|---------|------------------|-----------|-----------|---------------|---------|
| | | | H&W | Pension | App Tr. | Vac. | Annuity | Other | LECET (*) | MISC (*) | | |
| Classification | | | | | | | | | | | | |
| Ironworker Reinforcing | \$31.82 | | \$8.50 | \$9.50 | \$0.60 | \$0.00 | \$3.00 | \$0.20 | \$0.00 | \$0.00 | \$53.62 | \$69.53 |
| Structural | \$31.32 | | \$8.50 | \$9.50 | \$0.60 | \$0.00 | \$3.00 | \$0.20 | \$0.00 | \$0.00 | \$53.12 | \$68.78 |
| Ornamental | \$31.32 | | \$8.50 | \$9.50 | \$0.60 | \$0.00 | \$3.00 | \$0.20 | \$0.00 | \$0.00 | \$53.12 | \$68.78 |
| Machine Mover/Rigger | \$31.32 | | \$8.50 | \$9.50 | \$0.60 | \$0.00 | \$3.00 | \$0.20 | \$0.00 | \$0.00 | \$53.12 | \$68.78 |
| Conveyer Mechanic | \$31.32 | | \$8.50 | \$9.50 | \$0.60 | \$0.00 | \$3.00 | \$0.20 | \$0.00 | \$0.00 | \$53.12 | \$68.78 |
| Maintenance/Heavy Hwy | \$31.32 | | \$8.50 | \$9.50 | \$0.60 | \$0.00 | \$3.00 | \$0.20 | \$0.00 | \$0.00 | \$53.12 | \$68.78 |
| Welder A | \$31.57 | | \$8.50 | \$9.50 | \$0.60 | \$0.00 | \$3.00 | \$0.20 | \$0.00 | \$0.00 | \$53.37 | \$69.15 |
| Welder B | \$31.82 | | \$8.50 | \$9.50 | \$0.60 | \$0.00 | \$3.00 | \$0.20 | \$0.00 | \$0.00 | \$53.62 | \$69.53 |
| Sheeter | \$31.32 | | \$8.50 | \$9.50 | \$0.60 | \$0.00 | \$3.00 | \$0.20 | \$0.00 | \$0.00 | \$53.12 | \$68.78 |
| Fence Erector | \$29.75 | | \$8.50 | \$9.50 | \$0.60 | \$0.00 | \$3.00 | \$0.20 | \$0.00 | \$0.00 | \$51.55 | \$66.42 |
| Ironworker | \$31.32 | | \$8.50 | \$9.50 | \$0.60 | \$0.00 | \$3.00 | \$0.20 | \$0.00 | \$0.00 | \$53.12 | \$68.78 |
| Apprentice | Percent | | | | | | | | | | | |
| Apprentice | | | | | | | | | | | | |
| 1st yr A | 60.00 | \$19.09 | \$8.50 | \$9.50 | \$0.60 | \$0.00 | \$0.75 | \$0.20 | \$0.00 | \$0.00 | \$38.64 | \$48.19 |
| 1st yr B | 65.00 | \$20.68 | \$8.50 | \$9.50 | \$0.60 | \$0.00 | \$0.75 | \$0.20 | \$0.00 | \$0.00 | \$40.23 | \$50.57 |
| 2nd yr A | 70.00 | \$22.27 | \$8.50 | \$9.50 | \$0.60 | \$0.00 | \$0.75 | \$0.20 | \$0.00 | \$0.00 | \$41.82 | \$52.96 |
| 2nd yr B | 75.00 | \$23.87 | \$8.50 | \$9.50 | \$0.60 | \$0.00 | \$0.75 | \$0.20 | \$0.00 | \$0.00 | \$43.42 | \$55.35 |
| 3rd yr A | 80.00 | \$25.46 | \$8.50 | \$9.50 | \$0.60 | \$0.00 | \$1.50 | \$0.20 | \$0.00 | \$0.00 | \$45.76 | \$58.48 |
| 3rd yr B | 85.00 | \$27.05 | \$8.50 | \$9.50 | \$0.60 | \$0.00 | \$1.50 | \$0.20 | \$0.00 | \$0.00 | \$47.35 | \$60.87 |
| 4th yr A | 90.00 | \$28.64 | \$8.50 | \$9.50 | \$0.60 | \$0.00 | \$2.25 | \$0.20 | \$0.00 | \$0.00 | \$49.69 | \$64.01 |
| 4th yr B | 95.00 | \$30.23 | \$8.50 | \$9.50 | \$0.60 | \$0.00 | \$2.25 | \$0.20 | \$0.00 | \$0.00 | \$51.28 | \$66.39 |
| 4th yr C | 100.00 | \$31.82 | \$8.50 | \$9.50 | \$0.60 | \$0.00 | \$2.25 | \$0.20 | \$0.00 | \$0.00 | \$52.87 | \$68.78 |

Special Calculation Note : Other is Impact Fund Training

Ratio :

1 Journeymen to 1 Apprentice

Jurisdiction (* denotes special jurisdictional note) :

ADAMS*, BROWN, BUTLER*, CLERMONT,

2 Journeymen to 2 Apprentice
10 Journeymen to 4 Apprentices

CLINTON*, HAMILTON, HIGHLAND*, WARREN*

Special Jurisdictional Note : Adams County Twps included: Bratton, Scott, Winchester, Wayne. Butler County Twps included: Oxford, St. Clair, Fairfield, Morgan, Liberty, Union, Ross, Reilly, Hanover, West Chester. In Clinton County, Manchester and South West Borrow. Highland County Twps included: Dotson, Salem, Clay, White Oak, Hamer, New Market, Concord, Jackson, Washington. Warren County Twps included: Harlan, Deerfield, Hamilton.

Details :

Structural Iron Work but not limited to:field fabrication, all loading to and including the erecting,rigging,assembly,dismantling, placing, temporary and permanent securing by any means of all structural iron,steel,ornamental lead,bronze,brass,copper,aluminum,glass all ferrous and non ferrous metal and composite material, precast prestressed and post-stressed concrete structures. Bridges and bridge rails,bridge viaducts,bucks bulkheads,bumper and bumper post,canopies and unistrut canopies,corrugated ferrous and non ferrous sheets when attached to steel frames,columns,beams,bar-joists,trusses,grinders,roof decking,electrical supports,elevator cars,elevator fronts and enclosures,erection of steel towers,flag poles, gymnasium equipment,stadium and arena seating,jail cell work,jail cell beds,benches,bunks,chairs,tables,mirrors,jail cell access doors,rigging and installation of machinery and equipment(erecting,aligning,anchoring and dismantling, erection and dismantling of tower cranes,derrick monorail systems, Chicago booms,overhead cranes,gantries,material and personnel hoists,tanks,hoppers and conveyors. All pre-engineered metal buildings and their entirety including siding,roofing, gutters, downspouts and erection of all.

Ornamental Iron Work but not limited to:all work in connection with field fabrication,handling including loading/off loading,sorting,cutting,fastening,anchoring,bending,hoisting,placing,burning,welding,and tying,dismantling of all materials used in miscellaneous iron or steel, for stairs,hand railings,rolling doors, rolling gates,rolling shutters,fence,windows,curtain wall,erection and welding of all metal, sash,architectural and ornamental treatments, but not necessarily limited to all sizes and types of ornamental,steel iron,lead,bronze,brass,copper,aluminum,all ferrous and non ferrous metals and composite materials

Fence Erector Iron Worker but not limited to: All work in connection with the field fabrication and erection of chain link fence,which includes but not limited to the loading and of the fence fabric and posts also the installation of the above.

Prevailing Wage Rate Skilled Crafts

Name of Union: Ironworker Local 290

Change # : LCN01-2021fbLoc290

Craft : Ironworker Effective Date : 01/27/2021 Last Posted : 01/27/2021

| | BHR | Fringe Benefit Payments | | | | | | Irrevocable Fund | | Total PWR | Overtime Rate | |
|------------------------|---------|-------------------------|---------|---------|--------|---------|--------|------------------|----------|-----------|---------------|---------|
| | | H&W | Pension | App Tr. | Vac. | Annuity | Other | LECET (*) | MISC (*) | | | |
| Classification | | | | | | | | | | | | |
| Ironworker Structural | \$29.68 | \$8.30 | \$9.50 | \$0.65 | \$0.00 | \$4.45 | \$0.02 | \$0.00 | \$0.00 | \$52.60 | \$67.44 | |
| Welder | \$29.68 | \$8.30 | \$9.50 | \$0.65 | \$0.00 | \$4.45 | \$0.02 | \$0.00 | \$0.00 | \$52.60 | \$67.44 | |
| Fence Erector | \$29.68 | \$8.30 | \$9.50 | \$0.65 | \$0.00 | \$4.45 | \$0.02 | \$0.00 | \$0.00 | \$52.60 | \$67.44 | |
| Reinforcing Rods | \$29.68 | \$8.30 | \$9.50 | \$0.65 | \$0.00 | \$4.45 | \$0.02 | \$0.00 | \$0.00 | \$52.60 | \$67.44 | |
| Machinery Mover | \$29.68 | \$8.30 | \$9.50 | \$0.65 | \$0.00 | \$4.45 | \$0.02 | \$0.00 | \$0.00 | \$52.60 | \$67.44 | |
| Sheeter | \$29.68 | \$8.30 | \$9.50 | \$0.65 | \$0.00 | \$4.45 | \$0.02 | \$0.00 | \$0.00 | \$52.60 | \$67.44 | |
| Metal Building Erector | \$29.68 | \$8.30 | \$9.50 | \$0.65 | \$0.00 | \$4.45 | \$0.02 | \$0.00 | \$0.00 | \$52.60 | \$67.44 | |
| Rigger & Erector | \$29.68 | \$8.30 | \$9.50 | \$0.65 | \$0.00 | \$4.45 | \$0.02 | \$0.00 | \$0.00 | \$52.60 | \$67.44 | |
| Apprentice | Percent | | | | | | | | | | | |
| 1st year | 65.05 | \$19.31 | \$8.30 | \$9.50 | \$0.65 | \$0.00 | \$2.95 | \$0.02 | \$0.00 | \$0.00 | \$40.73 | \$50.38 |
| 2nd year | 75.07 | \$22.28 | \$8.30 | \$9.50 | \$0.65 | \$0.00 | \$2.95 | \$0.02 | \$0.00 | \$0.00 | \$43.70 | \$54.84 |
| 3rd year | 85.05 | \$25.24 | \$8.30 | \$9.50 | \$0.65 | \$0.00 | \$2.95 | \$0.02 | \$0.00 | \$0.00 | \$46.66 | \$59.28 |
| 4th year | 95.05 | \$28.21 | \$8.30 | \$9.50 | \$0.65 | \$0.00 | \$2.95 | \$0.02 | \$0.00 | \$0.00 | \$49.63 | \$63.74 |

Special Calculation Note : Other is for Industry Fund.

Ratio :

3 Journeymen to 1 Apprentice

Jurisdiction (* denotes special jurisdictional note) :

ALLEN*, AUGLAIZE, BUTLER*, CHAMPAIGN*, CLARK, CLINTON, DARKE, FAYETTE*, GREENE, HARDIN*, HIGHLAND*, LOGAN*, MADISON*, MERCER*, MIAMI, MONTGOMERY, PREBLE, SHELBY, VAN WERT*, WARREN*

Special Jurisdictional Note : Allen County Twps included are: Auglaize, Perry, Shawnee, Amanda, Spencer, Marion, Sugar Creek, American, Bath, Jackson. Butler County Twps included are: Milford, Wayne, Madison, Lemon. Champaign Cnty Twps included are: Union, Urbana, Jackson, Concord, Salem, Mad River, Johnson, Harrison, Adams. Fayette County Twps included are: Green, Jasper,

Concord, Jefferson. Hardin County Twps included are: Round Head, Marion, Liberty. Highland County Twps included are: Fairfield, Penn, Union, Marshall, Liberty, Paint, Brush Creek. Logan County Twps included are: Richland, Stokes, Bloomfield, Washington, Harrison, McArthur, Lake, Liberty, Pleasant, Miami. Madison County Twps included are: Stokes. Mercer County Twps included are: Dublin, Washington, Jefferson, Recovery, Gibson, Union, Liberty, Butler, Granville, Center, Hopewell, Franklin, Marion. VanWert County Twps included are: Jennings. Warren County Twps included are: Franklin, Clear Creek, Turtle Creek, Wayne, Massie, Washington, Salem, Union.

Details :

Structural Iron Work but not limited to: field fabrication, all loading to and including the erecting, rigging, assembly, dismantling, placing, temporary and permanent securing by any means of all structural iron, steel, ornamental lead, bronze, brass, copper, aluminum, glass all ferrous and non ferrous metal and composite material, precast prestressed and post-stressed concrete structures. Bridges and bridge rails, bridge viaducts, bucks bulkheads, bumper and bumper post, canopies and unistrut canopies, corrugated ferrous and non ferrous sheets when attached to steel frames, columns, beams, bar-joists, trusses, grinders, roof decking, electrical supports, elevator cars, elevator fronts and enclosures, erection of steel towers, flag poles, gymnasium equipment, stadium and arena seating, jail cell work, jail cell beds, benches, bunks, chairs, tables, mirrors, jail cell access doors, rigging and installation of machinery and equipment (erecting, aligning, anchoring and dismantling, erection and dismantling of tower cranes, derrick monorail systems, Chicago booms, overhead cranes, gantries, material and personnel hoists, tanks, hoppers and conveyors. All pre-engineered metal buildings and their entirety including siding, roofing, gutters, downspouts and erection of all.

Ornamental Iron Work but not limited to: all work in connection with field fabrication, handling including loading/off loading, sorting, cutting, fastening, anchoring, bending, hoisting, placing, burning, welding, and tying, dismantling of all materials used in miscellaneous iron or steel, for stairs, hand railings, rolling doors, rolling gates, rolling shutters, fence, windows, curtain wall, erection and welding of all metal, sash, architectural and ornamental treatments, but not necessarily limited to all sizes and types of ornamental, steel iron, lead, bronze, brass, copper, aluminum, all ferrous and non ferrous metals and composite materials

Fence Erector Iron Worker but not limited to: All work in connection with the field fabrication and erection of chain link fence, which includes but not limited to the loading and of the fence fabric and posts also the installation of the above.

Prevailing Wage Rate

Skilled Crafts

Name of Union: Labor Hwy 3

Change # : LCN01-2021fbLocalHwy3

Craft : Laborer Group 1 Effective Date : 05/01/2021 Last Posted : 04/21/2021

| | BHR | | Fringe Benefit Payments | | | | | Irrevocable Fund | | Total PWR | Overtime Rate | |
|--------------------|---------|---------|-------------------------|---------|---------|--------|---------|------------------|-----------|-----------|---------------|----------|
| | | | H&W | Pension | App Tr. | Vac. | Annuity | Other | LECET (*) | | | MISC (*) |
| Classification | | | | | | | | | | | | |
| Laborer Group 1 | \$33.27 | | \$7.50 | \$3.90 | \$0.45 | \$0.00 | \$0.00 | \$0.00 | \$0.10 | \$0.00 | \$45.22 | \$61.86 |
| Group 2 | \$33.44 | | \$7.50 | \$3.90 | \$0.45 | \$0.00 | \$0.00 | \$0.00 | \$0.10 | \$0.00 | \$45.39 | \$62.11 |
| Group 3 | \$33.77 | | \$7.50 | \$3.90 | \$0.45 | \$0.00 | \$0.00 | \$0.00 | \$0.10 | \$0.00 | \$45.72 | \$62.61 |
| Group 4 | \$34.22 | | \$7.50 | \$3.90 | \$0.45 | \$0.00 | \$0.00 | \$0.00 | \$0.10 | \$0.00 | \$46.17 | \$63.28 |
| Watch Person | \$26.00 | | \$7.50 | \$3.90 | \$0.45 | \$0.00 | \$0.00 | \$0.00 | \$0.10 | \$0.00 | \$37.95 | \$50.95 |
| Apprentice | Percent | | | | | | | | | | | |
| 0-1000 hrs | 60.00 | \$19.96 | \$7.50 | \$3.90 | \$0.45 | \$0.00 | \$0.00 | \$0.00 | \$0.10 | \$0.00 | \$31.91 | \$41.89 |
| 1001-2000 hrs | 70.00 | \$23.29 | \$7.50 | \$3.90 | \$0.45 | \$0.00 | \$0.00 | \$0.00 | \$0.10 | \$0.00 | \$35.24 | \$46.88 |
| 2001-3000 hrs | 80.00 | \$26.62 | \$7.50 | \$3.90 | \$0.45 | \$0.00 | \$0.00 | \$0.00 | \$0.10 | \$0.00 | \$38.57 | \$51.87 |
| 3001-4000 hrs | 90.00 | \$29.94 | \$7.50 | \$3.90 | \$0.45 | \$0.00 | \$0.00 | \$0.00 | \$0.10 | \$0.00 | \$41.89 | \$56.86 |
| More than 4000 hrs | 100.00 | \$33.27 | \$7.50 | \$3.90 | \$0.45 | \$0.00 | \$0.00 | \$0.00 | \$0.10 | \$0.00 | \$45.22 | \$61.86 |

Special Calculation Note : Watchmen have no Apprentices. Tunnel Laborer rate with air-pressurized add \$1.00 to the above wage rate.

Ratio :

- 1 Journeymen to 1 Apprentice
- 3 Journeymen to 1 Apprentice thereafter

Jurisdiction (* denotes special jurisdictional note) :

ADAMS, ALLEN, ASHLAND, ATHENS, AUGLAIZE, BELMONT, BROWN, BUTLER, CARROLL, CHAMPAIGN, CLARK, CLERMONT, CLINTON, COLUMBIANA, COSHOCTON, CRAWFORD, DARKE, DEFIANCE, DELAWARE, FAIRFIELD, FAYETTE, FRANKLIN, FULTON, GALLIA, GREENE, GUERNSEY, HAMILTON, HANCOCK, HARDIN, HARRISON, HENRY, HIGHLAND, HOCKING, HOLMES, JACKSON, JEFFERSON, KNOX, LAWRENCE, LICKING, LOGAN, MADISON, MARION, MEIGS, MERCER, MIAMI, MONROE, MONTGOMERY, MORGAN, MORROW, MUSKINGUM, NOBLE, PAULDING, PERRY, PICKAWAY, PIKE, PREBLE, PUTNAM, RICHLAND, ROSS, SCIOTO, SENECA, SHELBY, TUSCARAWAS.

Special Jurisdictional Note : Hod Carriers and Common Laborers - Heavy, Highway, Sewer, Waterworks, Utility, Airport, Railroad, Industrial and Building Site, Sewer Plant, Waste Water Treatment Facilities Construction

Details :

Group 1

Laborer (Construction); Plant Laborer or Yardman, Right-of-way Laborer, Landscape Laborer, Highway Lighting Worker, Signalization Worker, (Swimming) Pool Construction Laborer, Utility Man, *Bridge Man, Handyman, Joint Setter, Flagperson, Carpenter Helper, Waterproofing Laborer, Slurry Seal, Seal Coating, Surface Treatment or Road Mix Laborer, Riprap Laborer & Grouter, Asphalt Laborer, Dump Man (batch trucks), Guardrail & Fence Installer, Mesh Handler & Placer, Concrete Curing Applicator, Scaffold Erector, Sign Installer, Hazardous Waste (level D), Diver Helper, Zone Person and Traffic Control.

*Bridge Man will perform work as per the October 31, 1949, memorandum on concrete forms, by and between the United Brotherhood of Carpenters and Joiners of America and the Laborers' International Union of North America, which states in; "the moving, cleaning, oiling and carrying to the next point of erection, and the stripping of forms which are not to be re-used, and forms on all flat arch work shall be done by members of the Laborers' International Union of North America."

Group 2

Asphalt Raker, Screwman or Paver, Concrete Puddler, Kettle Man (pipeline), All Machine-Driven Tools (Gas, Electric, Air), Mason Tender, Brick Paver, Mortar Mixer, Skid Steer, Sheeting & Shoring Person, Surface Grinder Person, Screedperson, Water Blast, Hand Held Wand, Power Buggy or Power Wheelbarrow, Paint Striper, Plastic fusing Machine Operator, Rodding Machine Operator, Pug Mill Operator, Operator of All Vacuum Devices Wet or Dry, Handling of all Pumps 4 inches and under (gas, air or electric), Diver, Form Setter, Bottom Person, Welder Helper (pipeline), Concrete Saw Person, Cutting with Burning Torch, Pipe Layer, Hand Spiker (railroad), Underground Person (working in sewer and waterline, cleaning, repairing and reconditioning). Tunnel Laborer (without air), Caisson, Cofferdam (below 25 feet deep), Air Track and Wagon Drill, Sandblaster Nozzle Person, Hazardous Waste (level B), ***Lead Abatement, Hazardous Waste (level C)

***Includes the erecting of structures for the removal, including the encapsulation and containment of Lead abatement process.

Group 3

Blast and Powder Person, Muckers will be defined as shovel men working directly with the miners, Wrencher (mechanical joints & utility pipeline), Yarnier, Top Lander, Hazardous Waste (level A), Concrete Specialist, Curb Setter and Cutter, Grade Checker, Concrete Crew in Tunnels. Utility pipeline Tappers, Waterline, Caulker, Signal Person will receive the rate equal to the rate paid the Laborer classification for which the Laborer is signaling.

Group 4

Miner, Welder, Gunitite Nozzle Person

A.) The Watchperson shall be responsible to patrol and maintain a safe traffic zone including but not limited to barrels, cones, signs, arrow boards, message boards etc.

The responsibility of a watchperson is to see that the equipment, job and office trailer etc. are secure.

Prevailing Wage Rate Skilled Crafts

Name of Union: Labor Local 534 Building

Change # : LCNO1-2021fbLoc534

Craft : Laborer Effective Date : 06/03/2021 Last Posted : 06/03/2021

| | BHR | | Fringe Benefit Payments | | | | | Irrevocable Fund | | Total PWR | Overtime Rate | |
|-------------------|----------------|---------|-------------------------|---------|---------|--------|---------|------------------|-----------|-----------|---------------|----------|
| | | | H&W | Pension | App Tr. | Vac. | Annuity | Other | LECET (*) | | | MISC (*) |
| Classification | | | | | | | | | | | | |
| Laborer Group 1 | \$29.39 | | \$7.50 | \$3.90 | \$0.45 | \$0.00 | \$0.00 | \$0.00 | \$0.10 | \$0.00 | \$41.34 | \$56.04 |
| Laborer Group 2 | \$29.49 | | \$7.50 | \$3.90 | \$0.45 | \$0.00 | \$0.00 | \$0.00 | \$0.10 | \$0.00 | \$41.44 | \$56.19 |
| Laborer Group 3 | \$29.59 | | \$7.50 | \$3.90 | \$0.45 | \$0.00 | \$0.00 | \$0.00 | \$0.10 | \$0.00 | \$41.54 | \$56.34 |
| Laborer Group 4 | \$29.72 | | \$7.50 | \$3.90 | \$0.45 | \$0.00 | \$0.00 | \$0.00 | \$0.10 | \$0.00 | \$41.67 | \$56.53 |
| Laborer Group 5 | \$29.97 | | \$7.50 | \$3.90 | \$0.45 | \$0.00 | \$0.00 | \$0.00 | \$0.10 | \$0.00 | \$41.92 | \$56.91 |
| Laborer Group 6 | \$29.74 | | \$7.50 | \$3.90 | \$0.45 | \$0.00 | \$0.00 | \$0.00 | \$0.10 | \$0.00 | \$41.69 | \$56.56 |
| Laborer Group 7 | \$28.94 | | \$7.50 | \$3.90 | \$0.45 | \$0.00 | \$0.00 | \$0.00 | \$0.10 | \$0.00 | \$40.89 | \$55.36 |
| Apprentice | Percent | | | | | | | | | | | |
| 0-1000 hrs | 60.00 | \$17.63 | \$7.50 | \$3.90 | \$0.45 | \$0.00 | \$0.00 | \$0.00 | \$0.10 | \$0.00 | \$29.58 | \$38.40 |
| 1001-2000 hrs | 70.00 | \$20.57 | \$7.50 | \$3.90 | \$0.45 | \$0.00 | \$0.00 | \$0.00 | \$0.10 | \$0.00 | \$32.52 | \$42.81 |
| 2001-3000 hrs | 80.00 | \$23.51 | \$7.50 | \$3.90 | \$0.45 | \$0.00 | \$0.00 | \$0.00 | \$0.10 | \$0.00 | \$35.46 | \$47.22 |
| 3001-4000 | 90.00 | \$26.45 | \$7.50 | \$3.90 | \$0.45 | \$0.00 | \$0.00 | \$0.00 | \$0.10 | \$0.00 | \$38.40 | \$51.63 |
| 4001 | 100.00 | \$29.39 | \$7.50 | \$3.90 | \$0.45 | \$0.00 | \$0.00 | \$0.00 | \$0.10 | \$0.00 | \$41.34 | \$56.04 |

Special Calculation Note : No special calculations for this skilled craft wage rate are required at this time.

Ratio :

1 Journeyman to 1 Apprentice
3 Journeyman to 1 Apprentice

Jurisdiction (* denotes special jurisdictional note) :

BUTLER, WARREN

Special Jurisdictional Note :

Details :

Note:

Group 1: Building & Common Laborer; All general laborers work including all forms of landscaping, Rough Rider - all pump's 4 inch or smaller, Small Pump Portable Generators-Bobcat to Cleanup, Firewatch and Monitor, (Safety Person)

Group 2: Asphalt Raker, Tamper, Smoother, Hand Air Pump, Hand air Tamper, Chisel, Power Tamper, Operator, Switch, Assemblies, Handling & Laying Precast Concrete Floors & Deck Tool Repairman.

Group 3: Concrete Specialist; Skid Steers (with attachments to perform Laborer's duties) Jack Hammer * Concrete Busterman, Barco Tamper Man, Power Georgia Buggy Man, Power Sweeper Man, Vibrator, Concrete Saw Man, Rail Spikers, Acetylene Burner, Pipelayers, Bos'n Cradleman, Bottom Man, Chipping Hammer Grade Checker, Radio Operator, Form Cleanout & blowout Man, Red Concrete Coloring Man (Electrical Safety)

Group 4: Mason Tender, Mortar Mixers & Scaffold Builders

Group 5: Fork Lift for Mason, all work involving Refractory Materials Including Demolition of Refractory Materials.

Asbestos Removal and Hazardous Waste Removal (handling, control, removal abatement, encapsulation or disposal of asbestos & hazardous waste),

Group 6: Gunnite Man, Sand Blaster, Concrete & Grout Pump & Hose Man, Blast Trac, Miners & Muckers, Free Air, Powderman or Blaster, Mortar or Gypsum Machineman, Welder, Scuba Diver.

Group 7: Watchman & Tool Checker/Toolroom Man

Prevailing Wage Rate Skilled Crafts

Name of Union: Operating Engineers - Building Local 18 - Zone III

Change # : LCN01-2021sksLoc18zone3

Craft : Operating Engineer Effective Date : 08/13/2021 Last Posted : 08/13/2021

| | BHR | | Fringe Benefit Payments | | | | | Irrevocable Fund | | Total PWR | Overtime Rate | |
|------------------------|----------------|---------|-------------------------|---------|---------|--------|---------|------------------|-----------|-----------|---------------|----------|
| | | | H&W | Pension | App Tr. | Vac. | Annuity | Other | LECET (*) | | | MISC (*) |
| Classification | | | | | | | | | | | | |
| Group A | \$39.14 | | \$8.76 | \$6.25 | \$0.85 | \$0.00 | \$0.00 | \$0.09 | \$0.00 | \$0.00 | \$55.09 | \$74.66 |
| Group B | \$39.02 | | \$8.76 | \$6.25 | \$0.85 | \$0.00 | \$0.00 | \$0.09 | \$0.00 | \$0.00 | \$54.97 | \$74.48 |
| Group C | \$37.98 | | \$8.76 | \$6.25 | \$0.85 | \$0.00 | \$0.00 | \$0.09 | \$0.00 | \$0.00 | \$53.93 | \$72.92 |
| Group D | \$36.80 | | \$8.76 | \$6.25 | \$0.85 | \$0.00 | \$0.00 | \$0.09 | \$0.00 | \$0.00 | \$52.75 | \$71.15 |
| Group E | \$31.34 | | \$8.76 | \$6.25 | \$0.85 | \$0.00 | \$0.00 | \$0.09 | \$0.00 | \$0.00 | \$47.29 | \$62.96 |
| Master Mechanic | \$39.39 | | \$8.76 | \$6.25 | \$0.85 | \$0.00 | \$0.00 | \$0.09 | \$0.00 | \$0.00 | \$55.34 | \$75.03 |
| Cranes 150'-180' | \$39.64 | | \$8.76 | \$6.25 | \$0.85 | \$0.00 | \$0.00 | \$0.09 | \$0.00 | \$0.00 | \$55.59 | \$75.41 |
| Cranes 180'-249' | \$40.14 | | \$8.76 | \$6.25 | \$0.85 | \$0.00 | \$0.00 | \$0.09 | \$0.00 | \$0.00 | \$56.09 | \$76.16 |
| Cranes 249' and over | \$40.39 | | \$8.76 | \$6.25 | \$0.85 | \$0.00 | \$0.00 | \$0.09 | \$0.00 | \$0.00 | \$56.34 | \$76.53 |
| Apprentice | Percent | | | | | | | | | | | |
| 1st Year | 50.00 | \$19.57 | \$8.76 | \$6.25 | \$0.85 | \$0.00 | \$0.00 | \$0.09 | \$0.00 | \$0.00 | \$35.52 | \$45.31 |
| 2nd Year | 60.00 | \$23.48 | \$8.76 | \$6.25 | \$0.85 | \$0.00 | \$0.00 | \$0.09 | \$0.00 | \$0.00 | \$39.43 | \$51.18 |
| 3rd Year | 70.00 | \$27.40 | \$8.76 | \$6.25 | \$0.85 | \$0.00 | \$0.00 | \$0.09 | \$0.00 | \$0.00 | \$43.35 | \$57.05 |
| 4th Year | 80.00 | \$31.31 | \$8.76 | \$6.25 | \$0.85 | \$0.00 | \$0.00 | \$0.09 | \$0.00 | \$0.00 | \$47.26 | \$62.92 |
| Field Mechanic Trainee | | | \$8.76 | \$6.25 | \$0.85 | | | \$0.09 | | | | |
| 1st Year | 50.00 | \$19.57 | \$8.76 | \$6.25 | \$0.85 | \$0.00 | \$0.00 | \$0.09 | \$0.00 | \$0.00 | \$35.52 | \$45.31 |
| 2nd Year | 60.00 | \$23.48 | \$8.76 | \$6.25 | \$0.85 | \$0.00 | \$0.00 | \$0.09 | \$0.00 | \$0.00 | \$39.43 | \$51.18 |
| 3rd Year | 70.00 | \$27.40 | \$8.76 | \$6.25 | \$0.85 | \$0.00 | \$0.00 | \$0.09 | \$0.00 | \$0.00 | \$43.35 | \$57.05 |
| 4th Year | 80.00 | \$31.31 | \$8.76 | \$6.25 | \$0.85 | \$0.00 | \$0.00 | \$0.09 | \$0.00 | \$0.00 | \$47.26 | \$62.92 |

Special Calculation Note : Other: Education & Safety \$0.09

Ratio :

For every (3) Operating Engineer Journeymen employed by the company there may be employed (1) Registered Apprentice or trainee Engineer through the

Jurisdiction (* denotes special jurisdictional note) :

ADAMS, ALLEN, ASHLAND, ATHENS, AUGLAIZE, BELMONT, BROWN, BUTLER, CARROLL, CHAMPAIGN, CLARK, CLERMONT,

referral when they are available. An apprentice, while employed as part of a crew per Article VIII, paragraph 78, will not be subject to the apprenticeship ratios in this collective bargaining agreement

CLINTON, COSHOCTON, CRAWFORD, DARKE, DEFIANCE, DELAWARE, FAIRFIELD, FAYETTE, FRANKLIN, FULTON, GALLIA, GREENE, GUERNSEY, HAMILTON, HANCOCK, HARDIN, HARRISON, HENRY, HIGHLAND, HOCKING, HOLMES, JACKSON, JEFFERSON, KNOX, LAWRENCE, LICKING, LOGAN, MADISON, MARION, MEIGS, MERCER, MIAMI, MONROE, MONTGOMERY, MORGAN, MORROW, MUSKINGUM, NOBLE, OTTAWA, PAULDING, PERRY, PICKAWAY, PIKE, PREBLE, PUTNAM, RICHLAND, ROSS, SANDUSKY, SCIOTO, SENECA, SHELBY, STARK, TUSCARAWAS, UNION, VAN WERT, VINTON, WARREN, WASHINGTON, WAYNE, WILLIAMS, WYANDOT

Special Jurisdictional Note :

Details :

Note: There will be a 10% increase for the apprentices on top of the percentages listed above provided they are operating mobile equipment. Mechanic Trainees will receive 10% increase if required to have CDL

Group A- Barrier Moving Machines; Boiler Operators or Compressor Operators, when compressor or boiler is mounted on crane (Piggyback Operation); Boom Trucks (all types); Cableways Cherry Pickers; Combination - Concrete Mixers & Towers; All Concrete Pumps with Booms; Cranes (all types); Compact Cranes, track or rubber over 4,000 pounds capacity; Cranes self-erecting, stationary, track or truck (all configurations); Derricks (all types); Draglines; Dredges (dipper, clam or suction) 3-man crew; Elevating Graders or Euclid Loaders; Floating Equipment; Forklift (rough terrain with winch/hoist); Gradalls; Helicopter Operators, hoisting building materials; Helicopter Winch Operators, Hoisting building materials; Hoes (All types); Hoists (with two or more drums in use); Horizontal Directional Drill; Hydraulic Gantry (lift system); Laser Finishing Machines; Laser Screed and like equipment; Lift Slab or Panel Jack Operators; Locomotives (all types); Maintenance Operator/Technician (Mechanic Operator/Technician and/or Welder); Mixers, paving (multiple drum); Mobile Concrete Pumps, with booms; Panelboards, (all types on site); Pile Drivers; Power Shovels; Prentice Loader; Rail Tamper (with automatic lifting and aligning device); Rotary Drills (all), used on caissons for foundations and sub-structure; Side Booms; Slip Form Pavers; Straddle Carriers (Building Construction on site); Trench Machines (over 24" wide); Tug Boats.

Group B - Articulating/end dumps (minus \$4.00/hour from Group B rate); Asphalt Pavers; Bobcat-type and/or skid steer loader with hoe attachment greater than 7000 lbs.; Bulldozers; CMI type Equipment; Concrete Saw, Vermeer-type; Endloaders; Hydro Milling Machine; Kolman-type Loaders (Dirt Loading); Lead Greasemen; Mucking Machines; Pettibone-Rail Equipment; Power Graders; Power Scoops; Power Scrapers; Push Cats;, Rotomills (all), grinders and planers of all types.

Group C - A-Frames; Air Compressors, Pressurizing Shafts or Tunnels; All Asphalt Rollers; Bobcat-type and/or Skid Steer Loader with or without attachments; Boilers (15 lbs. pressure and over); All Concrete Pumps (without booms with 5 inch system); Fork Lifts (except masonry); Highway Drills - all types (with integral power); Hoists (with one drum); House Elevators (except those automatic call button controlled), Buck Hoists, Transport Platforms, Construction Elevators; Hydro Vac/Excavator (when a second person is needed, the rate of pay will be "Class E"); Man Lifts; Material hoist/elevators; Mud Jacks; Pressure Grouting; Pump Operators (installing or operating Well Points or other types of Dewatering Systems); Pumps (4 inches and over discharge); Railroad Tie (Inserter/Remover); Rotovator (Lime-Soil Stabilizer); Submersible Pumps (4" and over discharge); Switch & Tie Tampers (without lifting and aligning device); Trench Machines (24" and under); Utility Operators.

Group D - Backfillers and Tampers; Ballast Re-locator; Batch Plant Operators; Bar and Joint Installing

Machines; Bull Floats; Burlap and Curing Machines; Clefplanes; Compressors, on building construction; Concrete Mixers, more than one bag capacity; Concrete Mixers, one bag capacity (side loaders); All Concrete Pumps (without boom with 4" or smaller system); Concrete Spreader; Conveyors, used for handling building materials; Crushers; Deckhands; Drum Fireman (in asphalt plants); Farm type tractors pulling attachments; Finishing Machines; Form Trenchers; Generators; Gunite Machines; Hydro-seeders; Pavement Breakers (hydraulic or cable); Post Drivers; Post Hole Diggers; Pressure Pumps (over 1/2") discharge); Road Widening Trenchers; Rollers (except asphalt); Self-propelled sub-graders; Shotcrete Machines; Tire Repairmen; Tractors, pulling sheepsfoot post roller or grader; VAC/ALLS; Vibratory Compactors, with integral power; Welders.

Group E – Allen Screed Paver (concrete); Boilers (less than 15 lbs. pressure); Cranes-Compact, track or rubber (under 4,000 pounds capacity); Directional Drill "Locator"; Fueling and greasing +\$3.00; Inboard/outboard Motor Boat Launches; Light Plant Operators; Masonry Fork Lifts; Oilers/Helpers; Power Driven Heaters (oil fired); Power Scrubbers; Power Sweepers; Pumps (under 4 inch discharge); Signalperson, Submersible Pumps (under 4" discharge).

Master Mechanics - Master Mechanic

Cranes 150' – 180' - Boom & Jib 150 - 180 feet

Cranes 180' – 249' - Boom & Jib 180 - 249 feet

Cranes 250' and over - Boom & Jib 250-feet or over

Prevailing Wage Rate Skilled Crafts

Name of Union: Operating Engineers - HevHwy Zone II

Change # : LCN01-2021sksLoc18hevhwyl

Craft : Operating Engineer Effective Date : 08/13/2021 Last Posted : 08/13/2021

| | BHR | | Fringe Benefit Payments | | | | | Irrevocable Fund | | Total PWR | Overtime Rate | |
|----------------------------|---------|---------|-------------------------|---------|---------|--------|---------|------------------|-----------|-----------|---------------|----------|
| | | | H&W | Pension | App Tr. | Vac. | Annuity | Other | LECET (*) | | | MISC (*) |
| Classification | | | | | | | | | | | | |
| Class A | \$39.14 | | \$8.76 | \$6.25 | \$0.85 | \$0.00 | \$0.00 | \$0.09 | \$0.00 | \$0.00 | \$55.09 | \$74.66 |
| Class B | \$39.02 | | \$8.76 | \$6.25 | \$0.85 | \$0.00 | \$0.00 | \$0.09 | \$0.00 | \$0.00 | \$54.97 | \$74.48 |
| Class C | \$37.98 | | \$8.76 | \$6.25 | \$0.85 | \$0.00 | \$0.00 | \$0.09 | \$0.00 | \$0.00 | \$53.93 | \$72.92 |
| Class D | \$36.80 | | \$8.76 | \$6.25 | \$0.85 | \$0.00 | \$0.00 | \$0.09 | \$0.00 | \$0.00 | \$52.75 | \$71.15 |
| Class E | \$31.34 | | \$8.76 | \$6.25 | \$0.85 | \$0.00 | \$0.00 | \$0.09 | \$0.00 | \$0.00 | \$47.29 | \$62.96 |
| Master Mechanic | \$39.39 | | \$8.76 | \$6.25 | \$0.85 | \$0.00 | \$0.00 | \$0.09 | \$0.00 | \$0.00 | \$55.34 | \$75.03 |
| Apprentice | Percent | | | | | | | | | | | |
| 1st Year | 50.00 | \$19.57 | \$8.76 | \$6.25 | \$0.85 | \$0.00 | \$0.00 | \$0.09 | \$0.00 | \$0.00 | \$35.52 | \$45.31 |
| 2nd Year | 60.00 | \$23.48 | \$8.76 | \$6.25 | \$0.85 | \$0.00 | \$0.00 | \$0.09 | \$0.00 | \$0.00 | \$39.43 | \$51.18 |
| 3rd Year | 70.00 | \$27.40 | \$8.76 | \$6.25 | \$0.85 | \$0.00 | \$0.00 | \$0.09 | \$0.00 | \$0.00 | \$43.35 | \$57.05 |
| 4th Year | 80.00 | \$31.31 | \$8.76 | \$6.25 | \$0.85 | \$0.00 | \$0.00 | \$0.09 | \$0.00 | \$0.00 | \$47.26 | \$62.92 |
| Field Mech Trainee Class 2 | | | | | | | | | | | | |
| 1st year | 50.00 | \$19.57 | \$8.76 | \$6.25 | \$0.85 | \$0.00 | \$0.00 | \$0.09 | \$0.00 | \$0.00 | \$35.52 | \$45.31 |
| 2nd year | 60.00 | \$23.48 | \$8.76 | \$6.25 | \$0.85 | \$0.00 | \$0.00 | \$0.09 | \$0.00 | \$0.00 | \$39.43 | \$51.18 |
| 3rd year | 70.00 | \$27.40 | \$8.76 | \$6.25 | \$0.85 | \$0.00 | \$0.00 | \$0.09 | \$0.00 | \$0.00 | \$43.35 | \$57.05 |
| 4th year | 80.00 | \$31.31 | \$8.76 | \$6.25 | \$0.85 | \$0.00 | \$0.00 | \$0.09 | \$0.00 | \$0.00 | \$47.26 | \$62.92 |

Special Calculation Note : Other: Education & Safety Fund is \$0.09 per hour.

Ratio :

For every (3) Operating Engineer Journeymen employed by the company, there may be employed (1) Registered Apprentice or Trainee Engineer through the referral when they are available. An Apprentice, while employed as part of a crew per Article VIII, paragraph 65 will not be subject to the apprenticeship ratios in this collective bargaining agreement

Jurisdiction (* denotes special jurisdictional note) :

ADAMS, ALLEN, ASHLAND, ATHENS, AUGLAIZE, BELMONT, BROWN, BUTLER, CARROLL, CHAMPAIGN, CLARK, CLERMONT, CLINTON, COSHOCTON, CRAWFORD, DARKE, DEFIANCE, DELAWARE, FAIRFIELD, FAYETTE, FRANKLIN, FULTON, GALLIA, GREENE, GUERNSEY, HAMILTON, HANCOCK, HARDIN, HARRISON, HENRY, HIGHLAND, HOCKING, HOLMES, HURON, JACKSON, JEFFERSON, KNOX, LAWRENCE, LICKING, LOGAN, LUCAS,

MADISON, MARION, MEIGS, MERCER, MIAMI,
MONROE, MONTGOMERY, MORGAN, MORROW,
MUSKINGUM, NOBLE, OTTAWA, PAULDING,
PERRY, PICKAWAY, PIKE, PREBLE, PUTNAM,
RICHLAND, ROSS, SANDUSKY, SCIOTO,
SENECA, SHELBY, STARK, TUSCARAWAS,
UNION, VAN WERT, VINTON, WARREN,
WASHINGTON, WAYNE, WILLIAMS, WOOD,
WYANDOT

Special Jurisdictional Note :

Details :

**Apprentices will receive a 10% increase on top of the percentages listed above provided they are operating mobile equipment. Mechanic Trainees will receive 10% increase if they are required to have CDL.

Class A - Air Compressors on Steel Erection; Asphalt Plant Engineers (Cleveland District Only); Barrier Moving Machine; Boiler Operators, Compressor Operators, or Generators, when mounted on a rig; Boom Trucks (all types); Cableways; Cherry Pickers; Combination- Concrete Mixers & Towers; Concrete Plants (over 4 yd capacity); Concrete Pumps; Cranes (all types); Compact Cranes track or rubber over 4,000 pounds capacity; Cranes self-erecting stationary, track or truck; Derricks (all types); Draglines; Dredges dipper, clam or suction; Elevating Graders or Euclid Loaders; Floating Equipment (all types); Gradalls; Helicopter Crew (Operator- hoist or winch); Hoes (all types); Hoisting Engines; Hoisting Engines, on shaft or tunnel work; Hydraulic Gantry (lifting system); Industrial-type Tractors; Jet Engine Dryer (D8 or D9) diesel Tractors; Locomotives (standard gauge); Maintenance Operators/Technicians (class A); Mixers, paving (single or double drum); Mucking Machines; Multiple Scrapers; Piledriving Machines (all types); Power Shovels, Prentice Loader; Quad 9 (double pusher); Rail Tamper (with automatic lifting and aligning device); Refrigerating Machines (freezer operation); Rotary Drills, on caisson work; Rough Terrain Fork Lift with winch/hoist; Side Booms; Slip Form Pavers; Survey Crew Party Chiefs; Tower Derricks; Tree Shredders; Trench Machines (over 24" wide); Truck Mounted Concrete Pumps; Tug Boats; Tunnel Machines and /or Mining Machines; Wheel Excavators.

Class B - Asphalt Pavers; Automatic Subgrade Machines, self-propelled (CMI-type); Bobcat-type and /or Skid Steer Loader with hoe attachment greater than 7000 lbs.; Boring Machine Operators (more than 48 inches); Bulldozers; Concrete Saws, Vermeer type; Endloaders; Horizontal Directional Drill (50,000 ft. lbs. thrust and over); Hydro Milling Machine; Kolman-type Loaders (production type-dirt); Lead Greasemen; Lighting and Traffic Signal Installation Equipment includes all groups or classifications; Maintenance Operators/Technicians, Class B; Material Transfer Equipment (shuttle buggy) Asphalt; Pettibone-Rail Equipment; Power Graders; Power Scrapers; Push Cats; Rotomills (all), Grinders and Planners of all types, Groovers (excluding walk-behinds); Trench Machines (24 inch wide and under).

Class C - A-Frames; Air Compressors, on tunnel work (low Pressure); Articulating/straight bed end dumps if assigned (minus \$4.00 per hour); Asphalt Plant Engineers (Portage and Summit Counties only); Bobcat-type and/or skid steer loader with or without attachments; Drones; Highway Drills (all types); HydroVac/Excavator (when a second person is needed, the rate of pay will be "Class E"); Locomotives (narrow gauge); Material Hoist/Elevators; Mixers, concrete (more than one bag capacity); Mixers, one bag capacity (side loader); Power Boilers (over 15 lbs. pressure); Pump Operators (installing or operating well Points); Pumps (4 inch and over discharge); Railroad Tie Inserter/Remover; Rollers, Asphalt; Rotovator (lime-soil Stabilizer); Switch & Tie Tampers (without lifting and aligning device); Utilities Operators, (small equipment); Welding Machines and Generators.

Class D – Backfillers and Tampers; Ballast Re-locator; Bar and Joint Installing Machines; Batch Plant Operators; Boring Machine Operators (48 inch or less); Bull Floats; Burlap and Curing Machines; Concrete Plants (capacity 4 yds. and under); Concrete Saws (multiple); Conveyors (highway); Crushers; Deckhands; Farm type tractors, with attachments (highway); Finishing Machines; Firemen, Floating Equipment (all types); Fork Lifts (highway), except masonry; Form Trenchers; Hydro Hammers; Hydro Seeders; Pavement Breakers (hydraulic or cable); Plant Mixers; Post Drivers; Post Hole Diggers; Power Brush Burners; Power Form

Handling Equipment; Road Widening Trenchers; Rollers (brick, grade, macadam); Self-Propelled Power Spreaders; Self-Propelled Sub-Graders; Steam Firemen; Survey Instrument men; Tractors, pulling sheepsfoot rollers or graders; Vibratory Compactors, with integral power.

Class E - Compressors (portable, Sewer, Heavy and Highway); Cranes-Compact, track or rubber under 4,000 pound capacity; Drum Firemen (asphalt plant); Fueling and greasing (Primary Operator with Specialized CDL Endorsement Add \$3.00/hr); Generators; Inboard-Outboard Motor Boat Launches; Masonry Fork Lifts; Oil Heaters (asphalt plant); Oilers/Helpers; Power Driven Heaters (oil fired); Power Scrubbers; Power Sweepers; Pumps (under 4 inch discharge); Signalperson; Survey Rodmen or Chairmen; Tire Repairmen; VAC/ALLS.
Master Mechanic - Master Mechanic

Prevailing Wage Rate Skilled Crafts

Name of Union: Painter Locals 123 & 238

Change # : LCR01-2021fbLoc123-238

Craft : Drywall Finisher Effective Date : 05/01/2021 Last Posted : 04/21/2021

| | BHR | Fringe Benefit Payments | | | | | | Irrevocable Fund | | Total PWR | Overtime Rate |
|--------------------------|---------|-------------------------|---------|---------|--------|---------|--------|------------------|----------|-----------|---------------|
| | | H&W | Pension | App Tr. | Vac. | Annuity | Other | LECET (*) | MISC (*) | | |
| Classification | | | | | | | | | | | |
| Painter Drywall Finisher | \$25.89 | \$5.79 | \$5.86 | \$0.31 | \$0.00 | \$0.00 | \$0.00 | \$0.00 | \$0.00 | \$37.85 | \$50.80 |
| Tapers and Finishers | \$25.89 | \$5.79 | \$5.86 | \$0.31 | \$0.00 | \$0.00 | \$0.00 | \$0.00 | \$0.00 | \$37.85 | \$50.80 |
| Apprentice | | | | | | | | | | | |
| 1st Year | \$14.83 | \$5.79 | \$2.30 | \$0.31 | \$0.00 | \$0.00 | \$0.00 | \$0.00 | \$0.00 | \$23.23 | \$30.64 |
| 2nd Year | \$17.63 | \$5.79 | \$2.30 | \$0.31 | \$0.00 | \$0.00 | \$0.00 | \$0.00 | \$0.00 | \$26.03 | \$34.85 |
| 3rd Year | \$20.43 | \$5.79 | \$2.30 | \$0.31 | \$0.00 | \$0.00 | \$0.00 | \$0.00 | \$0.00 | \$28.83 | \$39.05 |
| 4th Year | \$21.84 | \$5.79 | \$2.30 | \$0.31 | \$0.00 | \$0.00 | \$0.00 | \$0.00 | \$0.00 | \$30.24 | \$41.16 |

Special Calculation Note : Apprentices shall be paid the proper % of the classification above.

Ratio :

1 Journeyman to 1 Apprentice per job

Jurisdiction (* denotes special jurisdictional note) :

BROWN, BUTLER, CLERMONT, CLINTON, HAMILTON, WARREN

Special Jurisdictional Note :

Details :

Industrial Work paid as commercial work above for each class which includes, Industrial Plants, repair garages, processing plants, storage tanks, warehouses, skeletons structures, bridges unless highest point of clearance is 60 feet or more whether new or old construction offices and office buildings in industrial sites are at industrial rates. Heavy & Highway Bridges-Guard Rails- Light Poles. A hazardous steeplejack rate shall apply on radio towers, stacks, light towers, water towers, steeples, skeleton steel, and exterior industrial conveyors over 25 feet, where such items require steeplejack methods and the rate of pay shall be a \$1.00 per hour above the industrial rate. Steeplejack rate to apply to bridges where highest point of clearance is 60 feet.

Prevailing Wage Rate Skilled Crafts

**Name of Union: Painter Locals 123 & 238
Commercial & Industrial**

Change # : LCR01-2021fbLoc123

Craft : Painter Effective Date : 05/01/2021 Last Posted : 04/21/2021

| | BHR | Fringe Benefit Payments | | | | | | Irrevocable Fund | | Total PWR | Overtime Rate |
|----------------------------|---------|-------------------------|---------|---------|--------|---------|--------|------------------|----------|-----------|---------------|
| | | H&W | Pension | App Tr. | Vac. | Annuity | Other | LECET (*) | MISC (*) | | |
| Classification | | | | | | | | | | | |
| Painter Brush Roll | \$25.89 | \$5.79 | \$5.86 | \$0.31 | \$0.00 | \$0.00 | \$0.00 | \$0.00 | \$0.00 | \$37.85 | \$50.80 |
| Paper Hanger | \$25.89 | \$5.79 | \$5.86 | \$0.31 | \$0.00 | \$0.00 | \$0.00 | \$0.00 | \$0.00 | \$37.85 | \$50.80 |
| Spray Painter | \$26.39 | \$5.79 | \$5.86 | \$0.31 | \$0.00 | \$0.00 | \$0.00 | \$0.00 | \$0.00 | \$38.35 | \$51.55 |
| Sand Blaster Water Blaster | \$26.64 | \$5.79 | \$5.86 | \$0.31 | \$0.00 | \$0.00 | \$0.00 | \$0.00 | \$0.00 | \$38.60 | \$51.92 |
| Elevated Tanks | \$26.89 | \$5.79 | \$5.86 | \$0.31 | \$0.00 | \$0.00 | \$0.00 | \$0.00 | \$0.00 | \$38.85 | \$52.30 |
| Apprentice | | | | | | | | | | | |
| 1st Year | \$14.82 | \$5.79 | \$2.30 | \$0.31 | \$0.00 | \$0.00 | \$0.00 | \$0.00 | \$0.00 | \$23.22 | \$30.63 |
| 2nd Year | \$17.63 | \$5.79 | \$2.30 | \$0.31 | \$0.00 | \$0.00 | \$0.00 | \$0.00 | \$0.00 | \$26.03 | \$34.85 |
| 3rd Year | \$20.43 | \$5.79 | \$2.30 | \$0.31 | \$0.00 | \$0.00 | \$0.00 | \$0.00 | \$0.00 | \$28.83 | \$39.05 |
| 4th Year | \$21.84 | \$5.79 | \$2.30 | \$0.31 | \$0.00 | \$0.00 | \$0.00 | \$0.00 | \$0.00 | \$30.24 | \$41.16 |

Special Calculation Note : Apprentices shall be paid the proper % of the classification above.

Ratio :

(1) Journeymen to (1) Apprentice per jobsite

Jurisdiction (* denotes special jurisdictional note) :

BROWN, BUTLER, CLERMONT, CLINTON, HAMILTON, WARREN

Special Jurisdictional Note :

Details :

Industrial Work paid as commercial work above for each class which includes, Industrial Plants, repair garages, processing plants, storage tanks, warehouses, skeletons structures, bridges unless highest point of clearance is 60 feet or more whether new or old construction offices and office buildings in industrial sites are at industrial rates. Heavy & Highway Bridges-Guard Rails- Light Poles. A hazardous steeplejack rate shall apply on radio towers, stacks, light towers, water towers, steeples, skeleton steel, and exterior industrial conveyors over 25 feet, where such items require steeplejack methods and the rate of pay shall be a \$1.00 per hour above the industrial rate. Steeplejack rate to apply to bridges where highest point of clearance is 60 feet.

Prevailing Wage Rate Skilled Crafts

Name of Union: Painter Local 123 & 238 Hvy Hwy

Change # : LCR01-2021fbLoc123

Craft : Painter Effective Date : 05/01/2021 Last Posted : 04/21/2021

| | BHR | Fringe Benefit Payments | | | | | | Irrevocable Fund | | Total PWR | Overtime Rate |
|--|---------|-------------------------|---------|---------|--------|---------|--------|------------------|----------|-----------|---------------|
| | | H&W | Pension | App Tr. | Vac. | Annuity | Other | LECET (*) | MISC (*) | | |
| Classification | | | | | | | | | | | |
| Painter Bridge Class 1 | \$36.28 | \$5.79 | \$5.86 | \$0.31 | \$0.00 | \$0.00 | \$0.00 | \$0.00 | \$0.00 | \$48.24 | \$66.38 |
| Bridge Painter, Rigger, Containment Builder, Spot Blaster Class 2 | \$29.28 | \$5.79 | \$5.86 | \$0.31 | \$0.00 | \$0.00 | \$0.00 | \$0.00 | \$0.00 | \$41.24 | \$55.88 |
| Equipment Operator/Field Mechanic, Grit Reclamation, Paint Mixer, Traffic Control, Boat Person Class 3 | \$29.28 | \$5.79 | \$5.86 | \$0.31 | \$0.00 | \$0.00 | \$0.00 | \$0.00 | \$0.00 | \$41.24 | \$55.88 |
| Concrete Sealing, Concrete Blasting/Power Washing, Etc. Class 4 | \$29.28 | \$5.79 | \$5.86 | \$0.31 | \$0.00 | \$0.00 | \$0.00 | \$0.00 | \$0.00 | \$41.24 | \$55.88 |
| Quality Control/Quality Assurance, Traffic Safety, Competent Person Class 5 | \$29.28 | \$5.79 | \$5.86 | \$0.31 | \$0.00 | \$0.00 | \$0.00 | \$0.00 | \$0.00 | \$41.24 | \$55.88 |
| Apprentice | | | | | | | | | | | |
| 1st Year | \$20.58 | \$5.79 | \$2.30 | \$0.31 | \$0.00 | \$0.00 | \$0.00 | \$0.00 | \$0.00 | \$28.98 | \$39.27 |
| 2nd Year | \$24.21 | \$5.79 | \$2.30 | \$0.31 | \$0.00 | \$0.00 | \$0.00 | \$0.00 | \$0.00 | \$32.61 | \$44.71 |
| 3rd Year | \$27.84 | \$5.79 | \$2.30 | \$0.31 | \$0.00 | \$0.00 | \$0.00 | \$0.00 | \$0.00 | \$36.24 | \$50.16 |
| 4th Year | \$29.65 | \$5.79 | \$2.30 | \$0.31 | \$0.00 | \$0.00 | \$0.00 | \$0.00 | \$0.00 | \$38.05 | \$52.87 |

Special Calculation Note : Apprentices shall be paid proper % of the classification above..

Ratio :

1 Journeyman to 1 Apprentice

Jurisdiction (* denotes special jurisdictional note) :

BROWN, BUTLER, CLERMONT, CLINTON, HAMILTON, WARREN

Special Jurisdictional Note :

Details :

Industrial Work paid as commercial work above for each class which includes, Industrial Plants, repair garages, processing plants, storage tanks, warehouses, skeletons structures, bridges unless highest point of clearance is 60 feet or more whether new or old construction offices and office buildings in industrial sites are at industrial rates. Heavy & Highway Bridges-Guard Rails- Light Poles. A hazardous steeplejack rate shall apply on radio towers, stacks, light towers, water towers, steeples, skeleton steel, and exterior industrial conveyors over 25 feet, where such items require steeplejack methods and the rate of pay shall be a \$1.00 per hour above the industrial rate. Steeplejack rate to apply to bridges where highest point of clearance is 60 feet.

Class 1 – Abrasive blasting of any kind.

Class 2 – Bridge painting, coating application of any kind. All steel surface preparation other than abrasive blasting. All necessary rigging and containment building. All remedial/ spot blasting.

Class 3 – Tend to all equipment including but not limited to abrasive blasting, power washing, spray painting, forklifts, hoists, trucks, etc. Load and unload trucks, handle materials, man safety boats, handle traffic control, clean up/ vacuum abrasive blast materials and related tasks.

Class 4 – All aspects of concrete coating/ sealing including but not limited to preparation, containment, etc.

Class 5 – Verify and record that all work is completed according to job specifications. Assure that all health and safety standards are adhered to. Assure all traffic is safely handled.

Prevailing Wage Rate Skilled Crafts

Name of Union: Painter Local 639

Change # : LCNO1-2015fbLoc639

Craft : Painter Effective Date : 06/10/2015 Last Posted : 06/10/2015

| | BHR | Fringe Benefit Payments | | | | | | Irrevocable Fund | | Total PWR | Overtime Rate |
|--------------------------------|---------|-------------------------|---------|---------|--------|---------|--------|------------------|----------|-----------|---------------|
| | | H&W | Pension | App Tr. | Vac. | Annuity | Other | LECET (*) | MISC (*) | | |
| Classification | | | | | | | | | | | |
| Painter Metal Finisher/Helpers | | | | | | | | | | | |
| Top Helper Class A | \$19.09 | \$3.65 | \$0.00 | \$0.00 | \$0.66 | \$0.00 | \$0.00 | \$0.00 | \$0.00 | \$23.40 | \$32.94 |
| Top Helper Class B | \$19.09 | \$3.65 | \$0.65 | \$0.00 | \$1.03 | \$0.00 | \$0.37 | \$0.00 | \$0.00 | \$24.79 | \$34.33 |
| Top Helper Class C | \$19.09 | \$3.65 | \$1.00 | \$0.00 | \$1.76 | \$0.00 | \$0.37 | \$0.00 | \$0.00 | \$25.87 | \$35.41 |
| Helper Class A | \$14.69 | \$3.65 | \$0.00 | \$0.00 | \$0.51 | \$0.00 | \$0.00 | \$0.00 | \$0.00 | \$18.85 | \$26.19 |
| Helper Class B | \$14.69 | \$3.65 | \$0.65 | \$0.00 | \$0.79 | \$0.00 | \$0.28 | \$0.00 | \$0.00 | \$20.06 | \$27.40 |
| Helper Class C | \$14.69 | \$3.65 | \$1.00 | \$0.00 | \$1.64 | \$0.00 | \$0.28 | \$0.00 | \$0.00 | \$21.26 | \$28.60 |
| New Hire 90 Days | \$11.00 | \$3.65 | \$0.00 | \$0.00 | \$0.00 | \$0.00 | \$0.00 | \$0.00 | \$0.00 | \$14.65 | \$20.15 |

Special Calculation Note : Other is Sick and Personal Time

Ratio :

Jurisdiction (* denotes special jurisdictional note) :

ADAMS, ALLEN, ASHLAND, ASHTABULA, ATHENS, AUGLAIZE, BELMONT, BROWN, BUTLER, CARROLL, CHAMPAIGN, CLARK, CLERMONT, CLINTON, COLUMBIANA, COSHOCTON, CRAWFORD, CUYAHOGA, DARKE, DEFIANCE, DELAWARE, ERIE, FAIRFIELD, FAYETTE, FRANKLIN, FULTON, GALLIA, GEauga, GREENE, GUERNSEY, HAMILTON, HANCOCK, HARDIN, HARRISON, HENRY, HIGHLAND, HOCKING, HOLMES, HURON, JACKSON, JEFFERSON, KNOX, LAKE, LAWRENCE, LICKING, LOGAN, LORAIN, LUCAS, MADISON, MAHONING, MARION, MEDINA, MEIGS, MERCER, MIAMI, MONROE, MONTGOMERY, MORGAN, MORROW, MUSKINGUM, NOBLE, OTTAWA, PAULDING, PERRY, PICKAWAY, PIKE, PORTAGE, PREBLE, PUTNAM, RICHLAND, ROSS, SANDUSKY,

SCIOTO, SENECA, SHELBY, STARK, SUMMIT,
TRUMBULL, TUSCARAWAS, UNION, VAN
WERT, VINTON, WARREN, WASHINGTON,
WAYNE, WILLIAMS, WOOD, WYANDOT

Special Jurisdictional Note :

Details :

Top Helper: Shall perform the responsibilities of a Helper and be responsible for the setup, break down, safety and quality of the company's product.

Helper : Shall be responsible for performing tasks in refinishing, compliance with safety procedures, setting up and breaking down job sites, scaffolding and swing stages and preparing surfaces for refinishing including but not limited to, masking and stripping and cleaning, oxidizing, polishing and scratch removal on various surfaces

Class A Workers: Less than 1 Year of Service.

Class B Workers: More than 1 and less than 8 Years of Service.

Class C Workers: More than 8 Years of Service.

Metal Polisher Scope of Work: Polishing, buffing, stripping, coloring, lacquering, spraying, cleaning and maintenance of ornamental and architectural metals, iron, bronze, nickel, aluminum and stainless steel and in mental specialty work, various stone finishes, stone specialty work and any other work pertaining to the finishing of metal, stones, woods, and any window washing/cleaning done in conjunction with this work, using chemicals, solvents, coatings and hand applied lacquer thinner, removing scratches from mirror finished metals, burnishing of bronze, statuary finishes on exterior and interior surfaces and the use of all tools required to perform such work, including but not limited to polishes, spray equipment and scaffolding.

Swing State Rate: All work on scaffold 4 sections or higher, including any boom lifts and swing stage scaffolds including the rigging and derigging of hanging/suspended swing stage systems and rappelling/bolson chair work, ADD \$1.50 per hour.

Prevailing Wage Rate Skilled Crafts

Name of Union: Painter Local 639 Zone 2 Sign

Change # : LCN01-2016fbLoc639

Craft : Painter Effective Date : 08/03/2016 Last Posted : 08/03/2016

| | BHR | Fringe Benefit Payments | | | | | | Irrevocable Fund | | Total PWR | Overtime Rate |
|--|---------|-------------------------|---------|---------|--------|---------|--------|------------------|----------|-----------|---------------|
| | | H&W | Pension | App Tr. | Vac. | Annuity | Other | LECET (*) | MISC (*) | | |
| Classification | | | | | | | | | | | |
| Painter Sign Journeyman Tech/Team Leader Class A | \$21.25 | \$1.33 | \$0.14 | \$0.00 | \$0.00 | \$0.00 | \$0.57 | \$0.00 | \$0.00 | \$23.29 | \$33.92 |
| Painter Sign Journeyman Tech/Team Leader Class B | \$21.25 | \$1.33 | \$0.14 | \$0.00 | \$0.41 | \$0.00 | \$0.57 | \$0.00 | \$0.00 | \$23.70 | \$34.32 |
| Painter Sign Journeyman Tech/Team Leader Class C | \$21.25 | \$1.33 | \$0.14 | \$0.00 | \$0.82 | \$0.00 | \$0.57 | \$0.00 | \$0.00 | \$24.11 | \$34.74 |
| Painter Sign Journeyman Tech/Team Leader Class D | \$21.25 | \$1.33 | \$0.14 | \$0.00 | \$1.23 | \$0.00 | \$0.57 | \$0.00 | \$0.00 | \$24.52 | \$35.14 |
| Sign Journeyman Class A | \$20.98 | \$1.33 | \$0.14 | \$0.00 | \$0.00 | \$0.00 | \$0.56 | \$0.00 | \$0.00 | \$23.01 | \$33.50 |
| Sign Journeyman Class B | \$20.98 | \$1.33 | \$0.14 | \$0.00 | \$0.40 | \$0.00 | \$0.56 | \$0.00 | \$0.00 | \$23.41 | \$33.90 |
| Sign Journeyman Class C | \$20.98 | \$1.33 | \$0.14 | \$0.00 | \$0.81 | \$0.00 | \$0.56 | \$0.00 | \$0.00 | \$23.82 | \$34.31 |
| Sign Journeyman Class D | \$20.98 | \$1.33 | \$0.14 | \$0.00 | \$1.21 | \$0.00 | \$0.56 | \$0.00 | \$0.00 | \$24.22 | \$34.71 |
| Tech Sign Fabrication/ Erector Class A | \$15.90 | \$1.33 | \$0.14 | \$0.00 | \$0.00 | \$0.00 | \$0.43 | \$0.00 | \$0.00 | \$17.80 | \$25.75 |
| Tech Sign Fabrication/ Erector Class B | \$15.90 | \$1.33 | \$0.14 | \$0.00 | \$0.31 | \$0.00 | \$0.43 | \$0.00 | \$0.00 | \$18.11 | \$26.06 |
| Tech Sign Fabrication/ Erector Class C | \$15.90 | \$1.33 | \$0.14 | \$0.00 | \$0.61 | \$0.00 | \$0.43 | \$0.00 | \$0.00 | \$18.41 | \$26.36 |
| Tech Sign Fabrication/ Erector Class D | \$15.90 | \$1.33 | \$0.14 | \$0.00 | \$0.92 | \$0.00 | \$0.43 | \$0.00 | \$0.00 | \$18.72 | \$26.67 |

Special Calculation Note : Other is for paid holidays.

Ratio :

Jurisdiction (* denotes special jurisdictional note) :

ADAMS, ALLEN, AUGLAIZE, BROWN, BUTLER,
CARROLL, CHAMPAIGN, CLARK, CLERMONT, CLINTON,
COLUMBIANA, COSHOCTON, CRAWFORD, DARKE,
DEFIANCE, DELAWARE, ERIE, FAIRFIELD, FAYETTE,
FRANKLIN, FULTON, GREENE, HAMILTON, HANCOCK,
HARDIN, HENRY, HIGHLAND, HOLMES, HURON,
JACKSON, KNOX, LICKING, LOGAN, LORAIN, LUCAS,
MADISON, MAHONING, MARION, MERCER, MIAMI,
MONTGOMERY, MORROW, MUSKINGUM, OTTAWA,
PAULDING, PERRY, PICKAWAY, PIKE, PREBLE,
PUTNAM, ROSS, SANDUSKY, SCIOTO, SENECA,
SHELBY, STARK, TRUMBULL, TUSCARAWAS, UNION,
VAN WERT, WARREN, WAYNE, WILLIAMS, WOOD,
WYANDOT

Special Jurisdictional Note :

Details :

Class A: less than 1 year.

Class B: 1-3 years.

Class C: 3-10 years.

Class D: More than 10 years.

Prevailing Wage Rate Skilled Crafts

Name of Union: Plasterer Local 132 (Cincinnati)

Change # : LCN02-2021fbLoc132

Craft : Plasterer Effective Date : 07/14/2021 Last Posted : 07/14/2021

| | BHR | | Fringe Benefit Payments | | | | | | Irrevocable Fund | | Total PWR | Overtime Rate |
|----------------|---------|---------|-------------------------|---------|---------|--------|---------|--------|------------------|----------|-----------|---------------|
| | | | H&W | Pension | App Tr. | Vac. | Annuity | Other | LECET (*) | MISC (*) | | |
| Classification | | | | | | | | | | | | |
| Plasterer | \$26.65 | | \$5.80 | \$8.25 | \$0.70 | \$0.00 | \$1.00 | \$0.00 | \$0.00 | \$0.00 | \$42.40 | \$55.72 |
| Apprentice | Percent | | | | | | | | | | | |
| 1st 900 hours | 70.00 | \$18.65 | \$5.80 | \$0.00 | \$0.70 | \$0.00 | \$1.00 | \$0.00 | \$0.00 | \$0.00 | \$26.15 | \$35.48 |
| 2nd 900 hours | 74.00 | \$19.72 | \$5.80 | \$0.00 | \$0.70 | \$0.00 | \$1.00 | \$0.00 | \$0.00 | \$0.00 | \$27.22 | \$37.08 |
| 3rd 900 hours | 78.00 | \$20.79 | \$5.80 | \$7.25 | \$0.70 | \$0.00 | \$1.00 | \$0.00 | \$0.00 | \$0.00 | \$35.54 | \$45.93 |
| 4th 900 hours | 82.00 | \$21.85 | \$5.80 | \$7.25 | \$0.70 | \$0.00 | \$1.00 | \$0.00 | \$0.00 | \$0.00 | \$36.60 | \$47.53 |
| 5th 900 hours | 86.00 | \$22.92 | \$5.80 | \$7.25 | \$0.70 | \$0.00 | \$1.00 | \$0.00 | \$0.00 | \$0.00 | \$37.67 | \$49.13 |
| 6th 900 hours | 90.00 | \$23.98 | \$5.80 | \$7.25 | \$0.70 | \$0.00 | \$1.00 | \$0.00 | \$0.00 | \$0.00 | \$38.74 | \$50.73 |
| 7th 900 hours | 94.00 | \$25.05 | \$5.80 | \$7.25 | \$0.70 | \$0.00 | \$1.00 | \$0.00 | \$0.00 | \$0.00 | \$39.80 | \$52.33 |
| 8th 900 hours | 98.00 | \$26.12 | \$5.80 | \$7.25 | \$0.70 | \$0.00 | \$1.00 | \$0.00 | \$0.00 | \$0.00 | \$40.87 | \$53.93 |

Special Calculation Note : No special calculations for this skilled craft wage rate are required at this time.

Ratio :

- 1 Journeyman to 1 Apprentice
- 4 Journeyman to 2 Apprentice
- 7 Journeyman to 3 Apprentice

Jurisdiction (* denotes special jurisdictional note) :

BROWN, BUTLER, CLERMONT, HAMILTON, HIGHLAND, WARREN

Special Jurisdictional Note :

Details :

Apprentice and Shop Hand Pension are \$1.00 less than Journeyman.

Prevailing Wage Rate Skilled Crafts

Name of Union: Plumber Pipefitter Local 392

Change # : LCR01-2022sksLoc392

Craft : Plumber/Pipefitter Effective Date : 02/16/2022 Last Posted : 02/16/2022

| | BHR | | Fringe Benefit Payments | | | | | | Irrevocable Fund | | Total PWR | Overtime Rate |
|--------------------|---------|---------|-------------------------|---------|---------|--------|---------|--------|------------------|----------|-----------|---------------|
| | | | H&W | Pension | App Tr. | Vac. | Annuity | Other | LECET (*) | MISC (*) | | |
| Classification | | | | | | | | | | | | |
| Plumber Pipefitter | \$35.01 | | \$8.58 | \$13.59 | \$0.54 | \$0.00 | \$0.00 | \$0.48 | \$0.00 | \$0.00 | \$58.20 | \$75.71 |
| Plumber Helper | \$21.33 | | \$7.30 | \$6.59 | \$0.50 | \$0.00 | \$0.00 | \$0.00 | \$0.00 | \$0.00 | \$35.72 | \$46.38 |
| Apprentice | Percent | | | | | | | | | | | |
| 1st yr | 45.00 | \$15.75 | \$8.38 | \$0.95 | \$0.54 | \$0.00 | \$0.00 | \$0.48 | \$0.00 | \$0.00 | \$26.10 | \$33.98 |
| 2nd yr | 50.02 | \$17.51 | \$8.38 | \$0.95 | \$0.54 | \$0.00 | \$0.00 | \$0.48 | \$0.00 | \$0.00 | \$27.86 | \$36.62 |
| 3rd yr | 55.00 | \$19.26 | \$8.38 | \$7.47 | \$0.54 | \$0.00 | \$0.00 | \$0.48 | \$0.00 | \$0.00 | \$36.13 | \$45.75 |
| 4th yr | 60.00 | \$21.01 | \$8.38 | \$7.47 | \$0.54 | \$0.00 | \$0.00 | \$0.48 | \$0.00 | \$0.00 | \$37.88 | \$48.38 |
| 5th yr | 75.00 | \$26.26 | \$8.38 | \$13.59 | \$0.54 | \$0.00 | \$0.00 | \$0.48 | \$0.00 | \$0.00 | \$49.25 | \$62.38 |

Special Calculation Note : OTHER IS: SUPPLEMENTAL UNEMPLOYMENT BENEFITS.

Ratio :

- 1 Journeymen to 1 Apprentice
- 4 Journeymen to 2 Apprentices
- 6 Journeymen to 3 Apprentices
- 10 Journeymen to 4 Apprentices
- 16 Journeymen to 5 Apprentices

When more than Sixteen (16) Journeymen are employed additional apprentices may be acquired at a ratio of one (1) apprentice to four (4) journeymen.

Special Jurisdictional Note :

Details :

Helpers shall be permitted to work on ONLY , Exterior Sewers, Concrete, Vitrified Clay or PVC Pipe and Digging and Backfilling for Piping Work. The ratio shall not exceed 2 helpers to 1 Journeymen when performing the scope of work listed above

Jurisdiction (* denotes special jurisdictional note) :
BROWN, BUTLER, CLERMONT, HAMILTON, WARREN

Prevailing Wage Rate Skilled Crafts

Name of Union: Roofer Local 42

Change # : LCNO1-2021sksLoc42

Craft : Roofer Effective Date : 12/15/2021 Last Posted : 12/15/2021

| | BHR | | Fringe Benefit Payments | | | | | Irrevocable Fund | | Total PWR | Overtime Rate | |
|----------------|---------|---------|-------------------------|---------|---------|--------|---------|------------------|-----------|-----------|---------------|----------|
| | | | H&W | Pension | App Tr. | Vac. | Annuity | Other | LECET (*) | | | MISC (*) |
| Classification | | | | | | | | | | | | |
| Roofer | \$28.85 | | \$8.02 | \$7.95 | \$0.32 | \$0.00 | \$1.25 | \$0.06 | \$0.00 | \$0.00 | \$46.45 | \$60.88 |
| Tradesmen | \$23.08 | | \$8.02 | \$6.36 | \$0.00 | \$0.00 | \$1.25 | \$0.03 | \$0.00 | \$0.00 | \$38.74 | \$50.28 |
| Apprentice | Percent | | | | | | | | | | | |
| 1st period | 60.00 | \$17.31 | \$8.02 | \$4.77 | \$0.03 | \$0.00 | \$1.25 | \$0.00 | \$0.00 | \$0.00 | \$31.38 | \$40.03 |
| 2nd period | 70.00 | \$20.19 | \$8.02 | \$5.56 | \$0.03 | \$0.00 | \$1.25 | \$0.00 | \$0.00 | \$0.00 | \$35.06 | \$45.15 |
| 3rd period | 80.00 | \$23.08 | \$8.02 | \$6.36 | \$0.03 | \$0.00 | \$1.25 | \$0.00 | \$0.00 | \$0.00 | \$38.74 | \$50.28 |

Special Calculation Note : Other is for Training Fund

Ratio :

Employer may employ 1 apprentice for every 2 journeymen in his employment.

Jurisdiction (* denotes special jurisdictional note) :

ADAMS, BROWN, BUTLER, CLERMONT, HAMILTON, HIGHLAND, WARREN

Special Jurisdictional Note :

Details :

Any Tradesman Worker completing 2,000 hours in (2) years may move to Journeyman status by utilizing the Training Yard to improve their skills. Tradesman Workers will be tested at these yards to determine their competency for Journeyman status. Tradesman Workers must schedule and successfully complete the industry test battery in order to gain journeyman status.

Prevailing Wage Rate Skilled Crafts

Name of Union: Sheet Metal Local 24 (Dayton)

Change # : LCR01-2021fbLoc24(Day)

Craft : Sheet Metal Worker Effective Date : 07/14/2021 Last Posted : 07/14/2021

| | BHR | | Fringe Benefit Payments | | | | | | Irrevocable Fund | | Total PWR | Overtime Rate |
|---------------------|---------|---------|-------------------------|---------|---------|--------|---------|--------|------------------|----------|-----------|---------------|
| | | | H&W | Pension | App Tr. | Vac. | Annuity | Other | LECET (*) | MISC (*) | | |
| Classification | | | | | | | | | | | | |
| Sheet Metal Worker | \$29.30 | | \$9.00 | \$15.00 | \$0.85 | \$0.00 | \$0.00 | \$0.00 | \$0.00 | \$0.00 | \$54.15 | \$68.80 |
| Apprentice | Percent | | | | | | | | | | | |
| Apprentice | | | | | | | | | | | | |
| 5th Year B | 85.00 | \$24.91 | \$8.76 | \$11.51 | \$0.85 | \$0.00 | \$0.00 | \$0.00 | \$0.00 | \$0.00 | \$46.03 | \$58.48 |
| 5th Year A | 80.00 | \$23.44 | \$8.68 | \$10.35 | \$0.85 | \$0.00 | \$0.00 | \$0.00 | \$0.00 | \$0.00 | \$43.32 | \$55.04 |
| 4th Year B | 75.00 | \$21.98 | \$8.60 | \$9.18 | \$0.85 | \$0.00 | \$0.00 | \$0.00 | \$0.00 | \$0.00 | \$40.61 | \$51.59 |
| 4th Year A | 70.00 | \$20.51 | \$8.52 | \$8.03 | \$0.85 | \$0.00 | \$0.00 | \$0.00 | \$0.00 | \$0.00 | \$37.91 | \$48.17 |
| 3rd year B | 65.00 | \$19.05 | \$8.45 | \$6.85 | \$0.85 | \$0.00 | \$0.00 | \$0.00 | \$0.00 | \$0.00 | \$35.20 | \$44.72 |
| 3rd Year A | 60.00 | \$17.58 | \$8.37 | \$5.69 | \$0.85 | \$0.00 | \$0.00 | \$0.00 | \$0.00 | \$0.00 | \$32.49 | \$41.28 |
| 2 Year B | 57.52 | \$16.85 | \$8.33 | \$5.11 | \$0.85 | \$0.00 | \$0.00 | \$0.00 | \$0.00 | \$0.00 | \$31.14 | \$39.57 |
| 2 Year A | 55.00 | \$16.12 | \$8.29 | \$4.52 | \$0.85 | \$0.00 | \$0.00 | \$0.00 | \$0.00 | \$0.00 | \$29.78 | \$37.83 |
| Probationary 1 Year | 52.50 | \$15.38 | \$8.25 | \$3.95 | \$0.85 | \$0.00 | \$0.00 | \$0.00 | \$0.00 | \$0.00 | \$28.43 | \$36.12 |

Special Calculation Note : No special calculations for this skilled craft wage rate are required at this time.

Ratio :

1 Journeyman to 1 Apprentice then,
1 Apprentice for every 2 Journeymen thereafter

Jurisdiction (* denotes special jurisdictional note) :

ALLEN, AUGLAIZE, BUTLER, CHAMPAIGN,
CLARK, CLINTON, DARKE, GREENE, HARDIN,
LOGAN, MERCER, MIAMI, MONTGOMERY,
PREBLE, SHELBY, VAN WERT, WARREN,
WYANDOT

Special Jurisdictional Note :

Details :

MUSKINGUM, NOBLE, OTTAWA, PAULDING,
PERRY, PICKAWAY, PIKE, PORTAGE, PREBLE,
PUTNAM, RICHLAND, ROSS, SANDUSKY,
SCIOTO, SENECA, SHELBY, STARK, SUMMIT,
TRUMBULL, TUSCARAWAS, UNION, VAN WERT,
VINTON, WARREN, WASHINGTON, WAYNE,
WILLIAMS, WOOD, WYANDOT

Special Jurisdictional Note :

Details :

Sprinkler Fitter work shall consist of the installation, dismantling, maintenance, repairs, adjustments, and corrections of all fire protection and fire control systems including the unloading, handling by hand, power equipment and installation of all piping or tubing, appurtenances and equipment pertaining thereto, including both overhead and underground water mains, fire hydrants and hydrant mains, standpipes and hose connections to sprinkler systems used in connection with sprinkler and alarm systems. Also all tanks and pumps connected thereto, also included shall be CO-2 and Cardox Systems, Dry Chemical Systems, Foam Systems and all other fire protection systems.

SHELBY, STARK, SUMMIT, TRUMBULL,
TUSCARAWAS, UNION, VAN WERT, VINTON,
WARREN, WASHINGTON, WAYNE, WILLIAMS,
WOOD, WYANDOT

Special Jurisdictional Note :

Details :

Sprinkler Fitter work shall consist of the installation, dismantling, maintenance, repairs, adjustments, and corrections of all fire protection and fire control systems including the unloading, handling by hand, power equipment and installation of all piping or tubing, appurtenances and equipment pertaining thereto, including both overhead and underground water mains, fire hydrants and hydrant mains, standpipes and hose connections to sprinkler systems used in connection with sprinkler and alarm systems. Also all tanks and pumps connected thereto, also included shall be CO-2 and Cardox Systems, Dry Chemical Systems, Foam Systems and all other fire protection systems.

Prevailing Wage Rate

Skilled Crafts

**Name of Union: Truck Driver Bldg & Hwy Class 1
Locals 20,40,92,92b,100,175,284,438,377,637,908,957**

Change # : LCRO1-2021fbBldgHwy

Craft : Truck Driver Effective Date : 05/21/2021 Last Posted : 05/21/2021

| | BHR | | Fringe Benefit Payments | | | | | Irrevocable Fund | | Total PWR | Overtime Rate | |
|---|----------------|---------|-------------------------|---------|---------|--------|---------|------------------|-----------|-----------|---------------|---------|
| | | | H&W | Pension | App Tr. | Vac. | Annuity | Other | LECET (*) | MISC (*) | | |
| Classification | | | | | | | | | | | | |
| Truck Driver CLASS 1 4 wheel service, dump, and batch trucks, Oil Distributor - Asphalt Distributor-Tandems | \$29.24 | | \$7.50 | \$8.50 | \$0.20 | \$0.00 | \$0.00 | \$0.00 | \$0.00 | \$0.00 | \$45.44 | \$60.06 |
| Apprentice | Percent | | | | | | | | | | | |
| First 6 months | 80.00 | \$23.39 | \$7.50 | \$8.50 | \$0.20 | \$0.00 | \$0.00 | \$0.00 | \$0.00 | \$0.00 | \$39.59 | \$51.29 |
| 7-12 months | 85.00 | \$24.85 | \$7.50 | \$8.50 | \$0.20 | \$0.00 | \$0.00 | \$0.00 | \$0.00 | \$0.00 | \$41.05 | \$53.48 |
| 13-18 months | 90.00 | \$26.32 | \$7.50 | \$8.50 | \$0.20 | \$0.00 | \$0.00 | \$0.00 | \$0.00 | \$0.00 | \$42.52 | \$55.67 |
| 19-24 months | 95.00 | \$27.78 | \$7.50 | \$8.50 | \$0.20 | \$0.00 | \$0.00 | \$0.00 | \$0.00 | \$0.00 | \$43.98 | \$57.87 |
| 25-30 months | 100.00 | \$29.24 | \$7.50 | \$8.50 | \$0.20 | \$0.00 | \$0.00 | \$0.00 | \$0.00 | \$0.00 | \$45.44 | \$60.06 |

Special Calculation Note : No special calculations for this skilled craft wage rate are required at this time.

Ratio :

3 Journeymen to 1 Apprentice

Jurisdiction (* denotes special jurisdictional note) :

ADAMS, ALLEN, ASHLAND, ASHTABULA, ATHENS, AUGLAIZE, BELMONT, BROWN, BUTLER, CARROLL, CHAMPAIGN, CLARK, CLERMONT, CLINTON, COLUMBIANA, COSHOCTON, CRAWFORD, DARKE, DEFIANCE, DELAWARE, ERIE, FAIRFIELD, FAYETTE, FRANKLIN, FULTON, GALLIA, GREENE,

GUERNSEY, HAMILTON, HANCOCK, HARDIN,
HARRISON, HENRY, HIGHLAND, HOCKING,
HOLMES, HURON, JACKSON, JEFFERSON,
KNOX, LAWRENCE, LICKING, LOGAN, LORAIN,
LUCAS, MADISON, MAHONING, MARION,
MEDINA, MEIGS, MERCER, MIAMI, MONROE,
MONTGOMERY, MORGAN, MORROW,
MUSKINGUM, NOBLE, OTTAWA, PAULDING,
PERRY, PICKAWAY, PIKE, PORTAGE, PREBLE,
PUTNAM, RICHLAND, ROSS, SANDUSKY,
SCIOTO, SENECA, SHELBY, STARK, SUMMIT,
TRUMBULL, TUSCARAWAS, UNION, VAN WERT,
VINTON, WARREN, WASHINGTON, WAYNE,
WILLIAMS, WOOD, WYANDOT

Special Jurisdictional Note :

Details :

** Asphalt - Oil spray bar man when operating from cab shall receive \$0.20 cents per hour above their Basic Hourly Rate.

Prevailing Wage Rate

Skilled Crafts

Name of Union: Truck Driver Bldg & Hwy Class 2
Locals 20,40,92,92b,100,175,284,438,377,637,908,957

Change # : LCRO1-2021fbBldgHwy

Craft : Truck Driver Effective Date : 05/21/2021 Last Posted : 05/21/2021

| | BHR | | Fringe Benefit Payments | | | | | Irrevocable Fund | | Total PWR | Overtime Rate | |
|---|----------------|---------|-------------------------|---------|---------|--------|---------|------------------|-----------|-----------|---------------|---------|
| | | | H&W | Pension | App Tr. | Vac. | Annuity | Other | LECET (*) | MISC (*) | | |
| Classification | | | | | | | | | | | | |
| Truck Driver CLASS 2 Tractor Trailer-Semi Tractor Trucks-Pole Trailers-Ready Mix Trucks-Fuel Trucks- Asphalt-Oil Spray bar men- 5 Axle & Over - Belly Dumps-End Dumps-Articulated Dump Trucks- Low boys-Heavy duty Equipment(irrespective of load carried) when used exclusively for transportation-Truck Mechanics (when needed) | \$29.66 | | \$7.50 | \$8.50 | \$0.20 | \$0.00 | \$0.00 | \$0.00 | \$0.00 | \$0.00 | \$45.86 | \$60.69 |
| Apprentice | Percent | | | | | | | | | | | |
| First 6 months | 80.00 | \$23.73 | \$7.50 | \$8.50 | \$0.20 | \$0.00 | \$0.00 | \$0.00 | \$0.00 | \$0.00 | \$39.93 | \$51.79 |
| 7-12 months | 85.00 | \$25.21 | \$7.50 | \$8.50 | \$0.20 | \$0.00 | \$0.00 | \$0.00 | \$0.00 | \$0.00 | \$41.41 | \$54.02 |
| 13-18 months | 90.00 | \$26.69 | \$7.50 | \$8.50 | \$0.20 | \$0.00 | \$0.00 | \$0.00 | \$0.00 | \$0.00 | \$42.89 | \$56.24 |
| 19-24 months | 95.00 | \$28.18 | \$7.50 | \$8.50 | \$0.20 | \$0.00 | \$0.00 | \$0.00 | \$0.00 | \$0.00 | \$44.38 | \$58.47 |
| 25-30 months | 100.00 | \$29.66 | \$7.50 | \$8.50 | \$0.20 | \$0.00 | \$0.00 | \$0.00 | \$0.00 | \$0.00 | \$45.86 | \$60.69 |

Special Calculation Note : No special calculations for this skilled craft wage rate are required at this time.

Ratio :

3 Journeymen to 1 Apprentice

Jurisdiction (* denotes special jurisdictional note) :

ADAMS, ALLEN, ASHLAND, ASHTABULA, ATHENS, AUGLAIZE, BELMONT, BROWN, BUTLER, CARROLL, CHAMPAIGN, CLARK, CLERMONT, CLINTON, COLUMBIANA, COSHOCTON, CRAWFORD, DARKE, DEFIANCE, DELAWARE, ERIE, FAIRFIELD, FAYETTE, FRANKLIN, FULTON, GALLIA, GREENE,

GUERNSEY, HAMILTON, HANCOCK, HARDIN,
HARRISON, HENRY, HIGHLAND, HOCKING,
HOLMES, HURON, JACKSON, JEFFERSON,
KNOX, LAWRENCE, LICKING, LOGAN, LORAIN,
LUCAS, MADISON, MAHONING, MARION,
MEDINA, MEIGS, MERCER, MIAMI, MONROE,
MONTGOMERY, MORGAN, MORROW,
MUSKINGUM, NOBLE, OTTAWA, PAULDING,
PERRY, PICKAWAY, PIKE, PORTAGE, PREBLE,
PUTNAM, RICHLAND, ROSS, SANDUSKY,
SCIOTO, SENECA, SHELBY, STARK, SUMMIT,
TRUMBULL, TUSCARAWAS, UNION, VAN WERT,
VINTON, WARREN, WASHINGTON, WAYNE,
WILLIAMS, WOOD, WYANDOT

Special Jurisdictional Note :

Details :

** Asphalt - Oil spray bar man when operating from cab shall receive \$0.20 cents per hour above their Basic Hourly Rate.

SECTION M

***SPECIAL PROVISIONS/TECHNICAL
SPECIFICATIONS***

**COLUMBIA ROAD TURN LANE AT US22/SR3
SPECIAL PROVISIONS/TECHNICAL SPECIFICATIONS**

The 2019 Ohio Department of Transportation Construction and Material Specifications and the Supplemental Specifications shall govern this project unless stated otherwise by the Warren County Engineer, herein referred to as “Engineer”, “Project Engineer” and “County Engineer”.

It is required that the bidder be an ODOT pre-qualified Contractor to complete the construction work required in these Bid Documents. The Contractor, Sub-Contractor, and Fabricators must meet or exceed the ODOT Minimum Skills Requirements for all Work Types involved in this project.

Construction Engineering and Project Inspection

The Warren County Engineer will provide all construction engineering and project inspection for the construction of this project.

Operations Schedule

The Contractor shall advise and coordinate all work with the Engineer. A detailed schedule of operations shall be furnished by the Contractor to the Engineer and shall list the order of operations and the time frame for the completion of each item of work. The Engineer and the Owner prior to the beginning of the work shall approve the schedule of operations. Changes to said schedule are to be issued in writing and approved by the Engineer before operations are changed or rescheduled. The Contractor shall schedule operations so that the improved areas have had sufficient time to cure, set and/or harden before the area is opened to traffic or use. The Contractor shall be responsible for the immediate repair of the improved area if any damage is done by traffic. The Contractor shall also be responsible for the immediate rectification of problems created in areas outside of the improved areas attributable to the failure of the improved area, i.e., the tracking of materials into unimproved areas.

Preconstruction Meeting

Prior to the commencement of the construction activities, the Warren County Engineer will arrange a meeting between the Contractor and the Warren County Engineer. The time, date, and location of said meeting will be determined after the awarding of the contract. All parties will be notified by the Warren County Engineer. At the preconstruction meeting the Contractor shall submit to the Project Manager a construction schedule, list of subcontractors, and list of suppliers.

Project Start Date

The Contractor shall begin the construction once a written notice-to-proceed has been given by the Board of Warren County Commissioners and a preconstruction meeting with the Warren County Engineer has been held. To accommodate the local school districts, the first day of construction is set to begin on or after May 31st, 2022.

**COLUMBIA ROAD TURN LANE AT US22/SR3
SPECIAL PROVISIONS/TECHNICAL SPECIFICATIONS**

Completion Time

All work shall be completed within 8 weeks after the written notice-to-proceed has been issued by the Board of Warren County Commissioners, a preconstruction meeting has been held, and construction has started. The contractor shall plan construction so that all work shall be completed and the road open on or prior to August 12th, 2022. Liquidated damages for non-completion beyond August 12th, 2022 shall follow the CMS 108.07. Once work has started it shall be expected that work will be performed every work day on the project in an expeditious manner until the project is complete unless of inclement weather.

Working Restrictions

No work shall be done between 6:00 p.m. Friday and 7:00 a.m. Monday or during holidays, unless approved by the County Engineer. In addition, night work of any type shall be strictly prohibited, unless approved by the County Engineer.

Payment of Work

Contractor Estimates shall not be submitted more than once a month to the County Engineer for work included in the Contract between the County Commissioners and the Contractor.

Retainage and Affidavits

The contractor shall provide the County Engineer with affidavits stating that all subcontractors and suppliers for this project have been paid in full in accordance with CMS 109.08. A percentage of the original contract bid amount shall be retained on this project. Until 50% of the original contract has been performed, 8% of the amount of work performed will be retained. Once 50% of the contract has been performed and thereafter, a total of 4% of the original contract bid amount will be retained. The entire retainage will be released to the Contractor after the final inspection has been performed, after the County Engineer has accepted the construction, and after all affidavits have been submitted to the County Engineer by the Contractor.

Change Orders

No change orders involving performance or nonperformance contract quantities of project materials shall be processed without direct approval by the Warren County Engineer.

Storage of Construction Materials

The Contractor shall obtain prior approval of the Owner and/or Engineer for the locations to be used for the temporary storage of construction materials, tools, and/or machinery. All such materials, tools, and machinery shall be neatly and compactly piled in such a manner as to cause the least inconvenience to the property owners and to traffic. Under no circumstances shall existing drainage courses be blocked or water hydrants, valves, or meter pits covered. The closure of the existing northbound lane and northbound left turn lane will be closed for the

**COLUMBIA ROAD TURN LANE AT US22/SR3
SPECIAL PROVISIONS/TECHNICAL SPECIFICATIONS**

duration of this project. The Contractor will be allowed to store material on the roadway in this area.

Protection of Areas Outside of Work Limits

The Contractor shall be responsible for the protection of areas outside of the designated work limits, but which may be adjacent to those work limits. This will include those areas used by construction traffic for access to and from the work areas. Where the Engineer determines that the Contractor's operations have been responsible for damage to areas outside of the work limits, the Contractor shall be responsible for the repair of the area subject to the approval of the Engineer. No additional compensation will be due to the Contractor for any repair of these areas. Do not use the local parking lots to store vehicles, equipment or materials.

Debris Removal

The Contractor shall be responsible for removal from the site of all construction debris material. All debris material shall be disposed of in a proper manner and shall be as directed by any applicable local, state or federal regulations. Contractor shall take precautions to avoid any demolition debris from entering the storm sewer. Any material that does fall into the storm sewer shall be removed as soon as possible.

Utility Notification

The Contractor shall notify at least 48 hours before breaking ground all public and/or private service corporation having wires, poles, conduits, manholes, or other structures that may be affected by the construction on this project, including all structures which are affected and not shown on the plans. Owners of underground utilities, which are members of OUPS, can be notified by calling 1-800-362-2764. Non-member underground utility owners must be called directly.

Utility Adjustments and Verification

The Contractor shall adjust to proposed grade all existing utility facilities, i.e. manholes, catch basins, valves, boxes, etc., prior to the commencement of paving operation. This shall include utility facilities, not shown on the plan, which may be found to be located within the pavement area. Work performed on the utility facilities shall be in strict accordance with the specifications of the applicable utility owner and shall be performed under the direction, supervision and inspection of said owner.

The contractor shall take precaution while excavating near existing utilities. If necessary, the contractor shall hand dig in areas near an existing utility. The Contractor shall hold Warren County harmless of liabilities which may arise from the damaging of existing utilities. The payment for hand digging in areas near existing utilities shall be paid for under the unit bid price for the pertinent item.

**COLUMBIA ROAD TURN LANE AT US22/SR3
SPECIAL PROVISIONS/TECHNICAL SPECIFICATIONS**

Existing Pipe

The location, size, type and depth of all existing pipe are shown as according to the best information. The Engineer will not be responsible for any variations found during construction. Where the plans provide for conduit to be connected to, or to cross either over or under, or close to an existing underground structure, it shall be the responsibility of the Contractor to locate the existing structure, both as to line and grade, before he starts to lay the proposed conduit, in order to assure compatibility of line and grade of the proposed conduit. Payment for all operations described above shall be included in the unit price bid for the pertinent conduit item.

Maintenance of Sewer Flows

The Contractor shall conduct his operations so as to maintain at all times storm water and sewer flows through existing facilities to remain in place and through existing facilities to be replaced until new facilities are completed and placed in use.

Grading at Inlets and Outfalls of Proposed Conduits

The cost of the necessary reconstruction and/or regrading of swales or disturbed areas at the inlets and outfalls of all proposed conduits shall be included in the price bid for the pertinent conduit and inlet items.

Restoration of Areas Disturbed by Drainage Facilities

Soil areas disturbed by construction of underdrains, trench drains, catch basins or other drainage facilities shall be regraded to drain properly and then restored. The cost of restoration of these soil areas is to be per the unit bid for the pertinent item. Pavement areas disturbed by the construction of the drainage facilities will be restored as per the asphalt pavement repair detail. Payment for the restoration of these areas will be at the unit price bid for the pertinent item. Damage done by the contractor outside of the project limits shall be restored by the contractor at the contractor's expense as directed by the Engineer.

Conduit End Treatment

Immediately after placement of any conduits, the Contractor shall construct the end treatments required by the plans at both the outlet and inlet ends. This shall include headwalls, concrete riprap, rock channel protection, sodding, etc.

Conduit, Drainage and Utility Items

Unless otherwise specified on the plans, the unit price bid for the pertinent conduit, drainage and/or utility item shall include the cost of all-necessary appurtenances, connections, fittings, plugs, tees, collars, masonry collars, butt joints, bedding, backfill, etc.

For proposed conduit and the removal of existing conduit, all trenches that are under or within three (3) feet of existing or proposed roadway pavement, shall be backfilled with

**COLUMBIA ROAD TURN LANE AT US22/SR3
SPECIAL PROVISIONS/TECHNICAL SPECIFICATIONS**

Type 1 or Type 3 granular backfill and shall be paid for under the unit price bid for the pertinent item.

Unless otherwise noted on the plans, the unit price for the pertinent conduit, drainage and/or utility item is to include the costs involved in the excavation of the trench in unclassified material, the supplying and placing of the required bedding material and the backfilling of the trench with the specified material to the appropriate subgrade elevations.

The contractor shall take precaution while excavating for pipe near existing utilities. If necessary, the contractor shall hand dig in areas where proposed pipe is to be installed near an existing utility. The Contractor shall hold Warren County harmless of liabilities which may arise from the damaging of existing utilities. The payment for hand digging in areas near existing utilities shall be paid for under the price bid for the pertinent item.

Item Special – Undercutting Subgrade

All subgrade areas beneath new pavement must be shaped and compacted in accordance with the plans and/or specifications.

Where areas of unsuitable subgrade material are found, the unsuitable material shall be removed and replaced as per Section 204. The removal of the material will be to the limits determined in the field by the Engineer, and the limits of the removal will be measured by the Engineer in order to determine quantities for payment. The Contractor shall be responsible for scheduling his operations with the Engineer so that the proper measurements may be obtained for these calculations. It is anticipated that the maximum depth of the excavation will be three (3) feet. An estimated quantity of 350 CY of Item Special Undercutting Subgrade has been included in the proposal for use in undercutting unsuitable soil areas as determined by the Engineer.

The Contractor shall remove the unsuitable materials from the site and the Contractor shall be responsible for the proper disposal of said waste materials. The Borrow materials used for replacing the unsuitable subgrade materials shall consist of soils as described in Section 203 and shall be of such unit weight as to be satisfactory for subgrade construction as required by the specifications. Granular materials shall not be used unless specifically authorized by the Engineer. The embankment materials shall be placed in layers and to the density requirements as described in Section 203.

The undercut areas beneath new pavement must be shaped and compacted using a heavy duty, tamping-type compactor. Compaction shall be in accordance with the requirements for soil embankment in Section 203.

The costs involved in removing the unsuitable material and furnishing, placing and compacting the Borrow materials shall be included in the unit bid price for Item Special Undercutting Subgrade, regardless of the haul distances required in furnishing the Borrow material.

The Contractor shall schedule and conduct all of his operations from removal of the existing pavement through the compaction of subgrade so as to protect and maintain at all times the condition of the exposed subgrade material. The Contractor shall take all necessary precautions

**COLUMBIA ROAD TURN LANE AT US22/SR3
SPECIAL PROVISIONS/TECHNICAL SPECIFICATIONS**

so as to provide proper drainage and prevent standing water on the subgrade. Any unsuitable subgrade conditions that are caused by either the action and/or inaction of the Contractor shall be corrected to the satisfaction of the Engineer by the Contractor at the Contractor's expense. Payment will be made at the unit bid price per CY of Item Special Undercutting Subgrade.

Item Special – Granular Repair of Subgrade

Where areas of unsuitable subgrade material are found, the unsuitable material shall be removed and replaced with one of the following:

- (1) all No. 1 crushed limestone or crushed air cooled slag choked with 4" of crushed 3/4" gravel
- (2) a 50%-50% mix of No.1 and No.2 crushed limestone or crushed air cooled slag choked with 4" of crushed 3/4" gravel

The removal of the material will be to the limits determined in the field by the Engineer, and the limits of the removal will be measured by the Engineer in order to determine quantities for payment. The Contractor shall be responsible for scheduling his operations with the Engineer so that the proper measurements may be obtained for these calculations. It is anticipated that the maximum depth of the excavation will be three (3) feet. An estimated quantity of 350 CY of Item Special Granular Repair of Subgrade has been included in the proposal for use in replacing unsuitable soil areas as determined by the Engineer.

The Contractor shall remove the unsuitable materials from the site and the Contractor shall be responsible for the proper disposal of said waste materials. The embankment materials shall be placed in layers and to the density requirements as described in Section 203.

The repaired subgrade areas beneath new pavement must be shaped and compacted using a heavy duty, tamping-type compactor. Compaction shall be in accordance with the requirements for soil embankment in Section 203.06.

The costs involved in removing the unsuitable material and furnishing, placing and compacting the granular materials shall be included in the unit bid price for Item Special Granular Repair of Subgrade, regardless of the haul distances required in furnishing the granular material or disposing of the unsuitable material.

The Contractor shall schedule and conduct all of his operations from removal of the existing pavement through the compaction of subgrade so as to protect and maintain at all times the condition of the exposed subgrade material. The Contractor shall take all necessary precautions so as to provide proper drainage and prevent standing water on the subgrade. Any unsuitable subgrade conditions that are caused by either the action and/or inaction of the Contractor shall be corrected to the satisfaction of the Engineer by the Contractor at the Contractor's expense. Payment will be made at the unit bid price per CY of Item Special Granular Repair of Subgrade.

**COLUMBIA ROAD TURN LANE AT US22/SR3
SPECIAL PROVISIONS/TECHNICAL SPECIFICATIONS**

Item 611 - Pipe Culverts, Sewers and Drains

This work shall consist of the construction or reconstruction of pipe culverts, sewers and drains hereinafter referred to as Type A, Type B, Type C, Type D, Type E and Type F Conduit. The work shall be in accordance with these specifications and in reasonably close conformity with the lines and grades shown on the plans or established by the Engineer. This work shall include the following: excavating for pipe and foundations for same, including clearing and grubbing and the removal of all materials necessary for placing the pipe except removals listed separately; furnishing and placing granular or concrete bedding and granular backfill as required; constructing and subsequently removing all necessary cofferdams, cribs and sheeting; pumping and dewatering; sealing or banding all pipe joints where required; furnishing and installing all necessary pipe bends and branches of a type at least equal to the conduit of which they become a part; joining to existing and proposed appurtenances as required; performing leakage tests as specified; restoration of disturbed facilities and surfaces; and providing erosion control pads and animal guards on underdrain and farm drain outlets.

See note under Conduit, Drainage and Utility Items regarding the installation of pipe near existing utilities.

Bedding and Backfill

All bedding and Backfill shall be in strict accordance with the specifications of ODOT Item 611 for the type of conduit specified. All trenches, that are under or within three (3) feet of existing or proposed roadway pavement, shall be backfilled in the following manner:

In the case of **Water Transmission and Distribution Lines, Storm Sewer, and Sanitary Sewer facilities**, granular material, Type 1 and Type 3 shall be used to backfill the trench from the bottom of the trench to a maximum distance of twelve (12) inches above the top of the facility within one (1) foot of subgrade. The granular material **MUST** be properly compacted and tested to ensure minimal settlement of the trench.

Payment for the work listed above shall be included in the price of Item 611.

Item 202 – Removals

This work shall consist of the removal, wholly or in part, and satisfactory disposal of all buildings, fences, guardrails, structures, old pavements, abandoned pipe lines, storage tanks, septic tanks, privy vaults, and any other obstructions which are not designated or permitted to remain, except for the obstructions to be removed and disposed of under other items in the contract. It shall also include the salvaging of designated materials and backfilling the resulting trenches, holes, and pits.

Item 202 – Pavement Removed

The removal of the pavement, including saw cutting, work shall comply with Item 202 Removal in the 2019 ODOT Construction and Materials Specifications. The Contractor shall saw cut the

**COLUMBIA ROAD TURN LANE AT US22/SR3
SPECIAL PROVISIONS/TECHNICAL SPECIFICATIONS**

pavement areas before removing to obtain a uniform edge. The saw cut shall be a minimum of one (1) foot or to sound pavement. This cost of this work shall be paid for in the unit price bid per SY of Item 202 Pavement Removed.

Item 203 – Excavation

All excavation work shall comply with Item 203 Excavation in the 2019 ODOT Construction and Materials Specifications.

Item 254 – Pavement Planing

This work shall conform to the 2019 Ohio Department of Transportation Construction and Material Specifications and shall be completed as directed by the Engineer. A butt joint shall be constructed at each start/stop locations. Each butt joint shall provide a smooth transition and shall also be properly sealed. The Contractor shall be responsible for removing and disposing of the cuttings. The cost of this work shall be paid for at the unit price bid per SY of Item 254 Pavement Planing.

Item 304 – Aggregate Base

Item 304 Aggregate Base shall be placed and compacted in the excavated areas in compliance with section 304.05 of the ODOT Construction and Material Specifications. Payment for this work shall be included in the bid price per CY for Item 304 Aggregate Base.

Item 407 – Tack Coat

Item 407 Tack Coat shall be applied at a rate of 0.10 gallon per square yard as directed by the Engineer. The application of the tack coat shall be applied to the entire width of the roadway immediately prior to the paving operation. Payment for the work listed above shall be included in the bid price per Gallon for Item 407 Tack Coat.

Asphalt Concrete

All material furnished and work performed shall conform to the 2019 Ohio Department of Transportation Construction and Material Specifications (ODOT CMS) for Item 301 Asphalt Concrete Base, Item 441 Asphalt Concrete Surface Course, and Item 441 Asphalt Concrete Intermediate Course.

The Contractor shall supply the County Engineer with a weigh ticket for each load of material placed. Periodic asphalt samples will be obtained for test purposes and an independent testing laboratory will perform tests.

No material shall be placed upon collected water. Asphalt surfaces shall be clear of dirt and debris prior to the placing of each subsequent lift. The Contractor shall adhere to the judgment of the Warren County Engineer's designated representatives.

**COLUMBIA ROAD TURN LANE AT US22/SR3
SPECIAL PROVISIONS/TECHNICAL SPECIFICATIONS**

The Contractor's attention is directed to Section 401.14 of the ODOT Specifications and he is hereby instructed that requirements for preparation of asphalt pavement to be resurfaced will be adhered to, and cost of any and all cleaning is to be included in the unit price bid for Item 301 and Item 441.

Butt Joints - A butt joint shall be constructed by grinding/planing existing pavement at each start/stop location. All grinding/ planing shall be in accordance with Item 254 Pavement Planing. The butt joints shall be constructed by grinding/planing the existing pavement for a length of 6 feet, varying in depth from 2” to 0”. The newly formed joint shall be properly installed so as to provide a smooth transition and shall also be properly sealed. The cost of constructing each butt joint by pavement planing/grinding shall be included and paid for in Item 441 Asphalt Concrete Surface Course.

Item 614 - Maintaining Traffic

Traffic control shall be the sole responsibility of the Contractor. The County of Warren shall be held harmless from liabilities caused by improper traffic control by the Contractor. The contractor shall indemnify Warren County from any and all liabilities due to improper maintenance of traffic. All road construction signs shall also be the responsibility of the Contractor. All traffic control shall conform to the Ohio Manual of Uniform Traffic Control Devices (OMUTCD) as well as the Ohio Department of Transportation Standards at all times.

Any devices that are determined by the Engineer to be substandard shall be repaired to the satisfaction of the Engineer or shall be immediately removed from the site and replaced with acceptable devices. Any temporary traffic control devices that are determined by the Engineer to become substandard during the course of the project shall be removed from the jobsite and immediately replaced by devices meeting the approval of the Engineer.

The Contractor shall provide and maintain all signs, barricades, labor, flagmen, steel plates, etc. for all work on this project. The Contractor shall notify the Warren County Engineer two (2) weeks prior to any road closure. The Contractor shall provide a minimum of one (1) Type III Barricades on south end of the closed section of Columbia Road. The barricades shall be chain linked together and fixed to the ground or some other object overnight. The Contractor shall maintain access to all driveways in the work area for the duration of the project. The Contractor shall provide alternatives to garbage collection services and emergency rescue services for all residents within the closed portions of roadway during the road closures. Any conflicting markings shall be removed or covered in accordance with Item 614.

One notice of road closure signs shall be erected by the Contractor two weeks in advance of the road closure. The signs shall be erected on the right hand side of the road facing traffic and shall be located in the field so as not to interfere with any permanent signs. The notice of closure signs shall be W20-H13-60 signs and shall state the followingCOLUMBIA ROAD WILL BE CLOSED FOR 8 WEEKS STARTING (EXACT CLOSURE DATE).

Access to addresses 8972-8976 Columbia Road shall be maintained at all times.

**COLUMBIA ROAD TURN LANE AT US22/SR3
SPECIAL PROVISIONS/TECHNICAL SPECIFICATIONS**

Lane closures on US22/SR3 are not permitted during the hours of 12:00pm (noon) to 7:00pm.

Due to northbound traffic being closed, “One Way” signs shall be used for the businesses on the west side of Columbia Road to ensure the vehicles travel south on Columbia Road when they leave these businesses. These signs shall be included in Item 614 Maintaining Traffic.

There is a plans note about Item 614 Detour Signing and it shall be included and paid for in Item 614 Maintaining Traffic.

There is a plane note about Item 614 Business Entrance Sign and it shall be included and paid for in Item 614 Maintaining Traffic.

Methods of maintaining traffic shall conform to the Manual of Uniform Traffic Control Devices and Item 614 of the ODOT Specifications. Payment for the work listed above shall be included in the Lump Sum price bid for Item 614 Maintaining Traffic.

Detour Route

Columbia Road northbound traffic will be closed for the duration of the project while southbound traffic will remain open. The detour routes are detailed on sheet number 5/24 in the plan set. Any changes shall be directed by the Engineer. The payment for all work associated with the road closure and detours shall be included in the Lump Sum bid price for Item 614 Maintaining Traffic

Trench for Widening

Trench excavation for base widening will be only on one side of the pavement. The open trench shall be adequately maintained and protected with drums or barricades at all times. Placement of proposed subbase and base material shall follow as closely as possible behind excavation operations. The length of time that the trench is left open shall be held to a minimum and shall at all times be subject to approval of the County Engineer. Payment for the work listed above shall be included in the Lump Sum price bid for Item 614 Maintaining Traffic.

Item 623 - Construction Layout Stakes and Surveying

All centerline of survey and property corner monumentation that is disturbed during construction shall be reset by a Professional Surveyor. Payment for the construction layout and work listed above shall be included in the Lump Sum bid price for Item 623 Construction Layout Stakes.

Pavement Marking

All pavement marking material and work shall comply with Item 641 Pavement Marking-General, Item 642 Traffic Paint, Type 1, and Item 644 Thermoplastic Pavement Marking in the 2019 ODOT Construction and Materials Specifications.

**COLUMBIA ROAD TURN LANE AT US22/SR3
SPECIAL PROVISIONS/TECHNICAL SPECIFICATIONS**

Item 653 – Topsoil Furnished and Placed

All applications of topsoil shall be applied as directed by the Engineer. Payment for the application shall be included in the bid price per CY for Item 653 Topsoil Furnished and Placed. The contractor shall submit supporting documentation concerning the applications.

Item 659 – Seeding & Mulching

All applications of seeding and mulching shall be applied as directed by the Engineer. Payment for the application shall be included in the bid price per SY for Item 659 Seeding & Mulching. The contractor shall submit supporting documentation concerning the applications.

Item 659 – Commercial Fertilizer

All applications of commercial fertilizer shall be applied as directed by the Engineer. Payment for the first application and all following applications shall be included in the bid price per Ton for Item 659 Commercial Fertilizer. The contractor shall submit supporting documentation concerning the applications.

Item 659 – Water

All applications of water shall be applied as directed by the Engineer. Payment for the first application and all following applications shall be included in the bid price per M Gal for Item 659 Water. The contractor shall submit supporting documentation concerning the applications.

Item 832 – Erosion Control

The Contractor shall furnish and install temporary sediment and erosion control best management practices required prior to any earth disturbing activity in accordance with Supplemental Specification 832. All pollution prevention measures must be maintained for the duration of construction. The Contractor shall remove all best management practices before the project is accepted. Payment for this work shall be included in the bid price per Each for Item 832 Erosion Control. This price is standard for all bidders, set at \$1.00 Each for a total of \$1,000.00.

Traffic Signal and Utility Items

Unless otherwise specified on the plans, the unit price bid for all traffic signal items and/or utility item shall include the cost of all-necessary appurtenances, connections, fittings, plugs, tees, collars, hardware, etc. Unless otherwise noted on the plans, the unit price bid for the pertinent traffic signal item and/or utility item is to include the costs involved in the excavation of the trench in unclassified material, the supplying and placing of the required bedding material and the backfilling of the trench with the specified material to the appropriate subgrade elevations.

The contractor shall take precaution while excavating for pipe near existing utilities. If necessary, the contractor shall hand dig in areas where proposed pipe is to be installed near an existing utility. The Contractor shall hold Warren County harmless of liabilities that may arise

**COLUMBIA ROAD TURN LANE AT US22/SR3
SPECIAL PROVISIONS/TECHNICAL SPECIFICATIONS**

from the damaging of existing utilities. The payment for hand digging in areas near existing utilities shall be paid for under the price bid for the pertinent item.

Item 102 - Pre-Qualification of Traffic Signal Bidders/Subcontractors

In addition to ODOT Item 102.01 and Supplemental Specification 1063, the Bidder shall have all the resources of personnel, equipment and material to provide the services outlined below. The Contractor shall have sufficient resources available at his/her local place of business to provide the requirements of this specification.

Personnel:

The Bidder shall employ for work on this contract journeyman electricians who have completed a program registered with the department of industrial relations and given 8000 hours of on-the-job training in the electrical trade. This training shall have included 800 hours of classroom training. Apprentices employed under this contract shall be registered in a bona fide apprenticeship program with an apprenticeship agency recognized by the Bureau Of Apprenticeship And Training Of The State Of Ohio or The U.S. Department Of Labor. At least one (1) journeyman electrician shall always be working on or supervising any phase of work associated with this contract. The crew leader responsible for this project shall be IMSA level Two certified.

Test Equipment:

The Bidder shall be able to test all elements of the traffic controllers related to this project in addition to all peripheral equipment, field wiring and interconnect lines. The Bidder shall own and have available in good operating condition specialized controller test equipment, VOM's, transistor testers, low impedance meters, ground fault meters, oscilloscopes, NEMA traffic signal controller testers, power line analyzers, communication line test equipment and recording conflict monitor testers to perform repair and the installation testing services required by this specification.

Equipment:

The Bidder shall have available all of the construction equipment and bucket/line trucks to perform the construction required by this contract. The equipment, along with skilled operators, shall be available for emergency maintenance and capable of completing the work required throughout the duration of the project.

Experience:

The Bidder shall be experienced and actively engaged in traffic signal installation work. A list of agencies and/or clients who use the Bidder's services shall be provided. If required, the Bidder may be requested to demonstrate the ability and produce equipment and employee qualifications needed to provide the services required by this specification.

Facilities:

The Bidder shall provide a facility for bench testing controllers. All materials and test equipment required shall be available at this facility in addition to providing and maintaining telephone service. The Engineer shall have access to the bench testing facility to inspect and observe controller and system testing as required by these specifications.

**COLUMBIA ROAD TURN LANE AT US22/SR3
SPECIAL PROVISIONS/TECHNICAL SPECIFICATIONS**

The cost of satisfying the pre-qualification requirements will be incidental to the project and included in the unit cost of each item. Controller testing shall be included as part of the controller pay item.

Item 105 - Inspection of Traffic Signal Work

In addition to Item 105.10, all materials and each part or detail of the work shall be subject to inspection by the Engineer or his representative. The Engineer shall inspect the following items prior to the contractor completing their installation:

1. Location of pedestal pole
2. Position of bagged signal head and overhead signs

The Engineer shall be notified a minimum of 48 hours in advance of the need for inspection. The Contractor shall contact the Engineer to arrange for inspection of the signal installation. Any work done without inspection of the above-mentioned items may be ordered removed and replaced at the Contractor's expense. The cost of satisfying the inspection requirements will be incidental to the project and included in the unit cost of each item.

Item 614 - Maintenance of Traffic Signal/Flasher Installation

The Contractor shall be responsible for maintaining traffic signal/flasher installations within the project under the following conditions:

1. Existing signal/flasher installations which the plans require the Contractor to adjust, modify, add onto or remove, or which the Contractor actually adjusts, modifies or otherwise disturbs. The Contractor shall be responsible for the entire installation (at an intersection) from the time his operations first disturb the installation until the installation has been subsequently removed or modified and the work is accepted.
2. New or reused signal/flasher installations or devices, installed by the Contractor. The Contractor shall be responsible for maintenance of these from the time of installation until the work is accepted.

General:

The Contractor shall correct as quickly as possible all outages or malfunctions. He shall provide the maintaining agency and the Engineer such addresses and phone numbers where his maintenance forces can be contacted. The Contractor shall provide one or more persons to receive all calls and dispatch the necessary maintenance forces to correct outages. Such a person or persons may be used to perform other duties as long as prompt attention is given to these calls and a person is readily available continuously 24 hours a day, 7 days a week. All lamp outages, cable outages, electrical failures, equipment malfunctions and misaligned signal heads shall be corrected to the satisfaction of the Engineer.

In the event new signals are damaged prior to acceptance, all damaged equipment except poles and control equipment shall be replaced by the Contractor to the satisfaction of the Engineer. The Contractor shall arrange for full traffic control until the signal is back in operation.

**COLUMBIA ROAD TURN LANE AT US22/SR3
SPECIAL PROVISIONS/TECHNICAL SPECIFICATIONS**

If poles and/or control equipment are damaged and must be replaced, the Contractor shall make temporary repairs as necessary to bring the signal back into full operation, and shall make permanent repairs or replacement as soon thereafter as possible.

Where outages are the direct result of a vehicle accident the response of the Contractor shall be as outlined above. The Contractor shall be responsible for collection of any compensation for this work from those responsible for the damage.

Where the Contractor has failed to, or cannot respond to, an outage or signal equipment malfunction, at these locations within his responsibility, within periods as specified above, any subsequent billings to the County for Police Services and maintenance services shall be deducted from monies due or to become due the contractor.

The Contractor shall provide the maintenance service entirely with his forces.

The Contractor shall be responsible for any damage to any traffic signal components required to be handled during the relocation of poles and revisions to the signal. When a traffic signal must be taken out of service by the Contractor due to construction procedures, this outage shall not exceed 4 hours and shall not include the hours of 7 to 9 AM and 4 to 6 PM. Any signalized intersection, where the signal is out of service due to construction procedures, or due to an outage or malfunction of equipment as described above, shall be protected, by the Contractor, by the installation of temporary "STOP" signs on the side streets.

Any vehicular traffic signal head, either new or existing which will be out of operation shall be covered in the manner described in 632.25.

Documentation:

The contractor shall maintain complete records of malfunctions including:

1. Time of notification of malfunction;
2. Time of work crews arrival to correct the malfunction;
3. Actions taken to correct the malfunction, including a list of parts repaired or replaced;
4. A diagnosis of reason for the malfunction and probability of reoccurrence;
5. Time of completion of the repair and system restored to full service.

A copy of these records shall be provided to the Engineer within three (3) working days following completion of each repair.

All costs resulting from the above requirements shall be considered to be included in the lump sum price bid for Item 614 – Maintaining Traffic, As Per Plan.

Item 633, Guarantee

The Contractor shall guarantee that the traffic control system installed as part of this contract shall operate satisfactorily for a period of 90 days following completion of the 10-day performance test. In the event of unsatisfactory operation the Contractor shall correct faulty installations, make repairs and replace defective parts with new parts of equal or better quality.

**COLUMBIA ROAD TURN LANE AT US22/SR3
SPECIAL PROVISIONS/TECHNICAL SPECIFICATIONS**

Equipment, material, and labor costs incurred in correcting an unsatisfactory operation due to poor workmanship or defective equipment shall be borne by the Contractor. Customary manufacturer's guarantees for all items shall be turned over to the Engineer following acceptance of the equipment.

The cost of guaranteeing satisfactory operation of the traffic control system will be incidental to the project and included in the unit cost of each item.

INVITATION TO BIDDERS

Sealed bids for the Columbia Road Turn Lane Project will be received at the Office of the Warren County Commissioners, 406 Justice Drive, Lebanon, Ohio 45036, until 9:30 a.m., March 15, 2022, and then at said time bids will be publicly opened and read aloud.

Bid documents and specifications are available online at the Warren County's Website at <https://www.co.warren.oh.us/Commissioners/Bids/>. Questions regarding the technical specifications should be directed to Dominic Brigano, Assistant Engineer, at the Warren County Engineer's Office, at (513) 695-3313. **Only ODOT prequalified contractors are eligible to submit bids for this Project.** Pre-qualification status must be in force **at the time of bid, at the time of award, and through the life of the construction contract.**

All bids shall be sealed and plainly marked "**Bid Opening – for Columbia Road Turn Lane Project, March 15, 2022 @ 9:30 a.m.**" Each bid shall contain the full name of each person or company submitting the bid and be accompanied by a bid bond for the full amount of the bid or a certified check in the amount equal to ten (10) percent of the bid.

A Bid guaranty, as required by Ohio Revised Code, Section 153.54, shall accompany each proposal submitted, as follows:

1. A Certified check, cashier's check, or letter of credit equal to ten (10) percent of the bid. A letter of credit may only be revocable by the Owner. Upon entering into a contract with the Owner, the contractor must file a performance bond for the amount of the contract, and the bid guaranty will then be returned to the successful and unsuccessful bidders upon contract execution.

OR

2. A form of bid guaranty bond (attached) for the full amount of the bid. Such bond is retained for the successful bidder but returned to unsuccessful bidders after the contract is executed.

Contact the Warren County Commissioner's Office at (513) 695-1250 should you need assistance in accessing the bidding information on the County's website. All contract addenda will be posted to the website prior to the bid opening. Bidders should check the website regularly to stay updated on any changes to the project.

Please be aware that if you are downloading this document to bid this project, and in order to stay updated on any change, please email Krystal Powell in the Commissioners' Office at krystal.powell@co.warren.oh.us with your contact information.

Attention of bidders is called to all of the requirements contained in the bid packet. No bidder may withdraw his/her bid within sixty (60) days after the actual date of the opening thereof. All bids shall be properly signed by an authorized representative of the bidder.

Warren County reserves the right to reject any or all bids submitted, to waive any irregularities in bids, and enter into a contract with the Bidder who in Warren County's consideration offered the lowest and best bid.

By order of the Board of County Commissioner, County of Warren, State of Ohio.

Tina Osborne, Clerk